

**b**

**5**

**basic  
collection**

*ÓPaini*



**5**

**basic  
collection**

*ÓPaini*



# index

<b>Presentazione azienda</b>	
The company	pag. 4
<hr/>	
<b>Norme internazionali</b>	
International Rules	pag. 6
<hr/>	
<b>Codici/Tabella finiture</b>	
Codes/Finishing Chart	pag. 7
<hr/>	
<b>Condizioni generali di vendita</b>	
General conditions of sale	pag. 94
<hr/>	

## **series index**

---

<b>Arena</b>	pag. 11
<b>Cooper</b>	pag. 21
<b>Creta 100</b>	pag. 29
<b>Smart</b>	pag. 35
<b>Smart medical</b>	pag. 41
<b>Mixo TC</b>	pag. 47
<b>Miura</b>	pag. 53
<b>Jolly</b>	pag. 57
<b>Liberty</b>	pag. 65
<b>Ornellaia</b>	pag. 73
<b>Arno</b>	pag. 83
<b>2T</b>	pag. 89

*OPaini*

# l'azienda

## **IT - Sono gli uomini a fare le aziende.**

Paini ne è un esempio.

Da piccola azienda artigiana fondata nel 1954, in 50 anni è arrivata ad essere una delle società leader nel settore.

Alla fine degli anni '60 raggiunse le dimensioni di piccola azienda, nel 1972 avvenne la sua trasformazione in società per azioni e fu necessaria anche la costruzione di uno stabilimento più moderno ed attrezzato.

Il momento di maggiore sviluppo dell'azienda ha coinciso con la nascita del monocomando, negli anni '80. Oggi la Paini è una grande industria che occupa un'area di circa 100.000 mq., di cui 70.000 coperti con una forza lavoro di 390 dipendenti.

La manodopera è attualmente specializzata ed è preparata anche per mezzo di corsi professionali interni; sono previsti stage dedicati a studenti d'istituti tecnico-commerciale. Siamo in grado di proporre un'ampia

gamma di rubinetteria: monocomando, arredobagno e cantiere, per ambienti da cucina, bagno e doccia. L'attuale produzione annua è di circa 4 milioni di pezzi. Il ciclo produttivo prevede l'utilizzo esclusivo di materie prime di qualità superiore, rispondenti alle rigorose norme UNI-CEE. Il Centro Ricerche è dotato di laboratori di prova ed analisi per studi ed acquisizione d'esperienze su problematiche meccaniche, chimiche e funzionali.

La produzione è completamente interna ed a ciclo completo, con ampio utilizzo di tecnologie moderne su macchine transfer e multimandrino. I controlli di qualità sono eseguiti in tutte le fasi di produzione e lavorazione, da quelle principali a quelle aggiunte. A questo scopo sono utilizzati anche strumenti automatici, programmati secondo precisi protocolli di valutazione per ogni lavorazione. La pulitura finale dei pezzi può essere robotizzata come

manuale, a seconda delle problematiche di produzione e del livello di finitura di ogni singolo pezzo. L'impianto di cromatura è uno dei più grandi del mondo nel settore della rubinetteria. Assicura automaticamente lo standard di spessore delle cromature richiesto dalle normative internazionali. I singoli pezzi viaggiano su telai trasportati per via aerea su birotaia elettromeccanica.

La verniciatura avviene internamente, con procedimenti di copertura sia a polvere epossidica che a liquido. Particolarmente apprezzabile l'impianto a trattamento P.V.D., impianto che permette di ricavare finiture più resistenti a quelle tradizionali. I ns. prodotti rispondono agli standard internazionali di molti enti d'unificazione ed è una delle poche aziende italiane del settore a disporre per i propri prodotti dei marchi d'omologazione IAPMO validi per gli U.S.A.



# the company

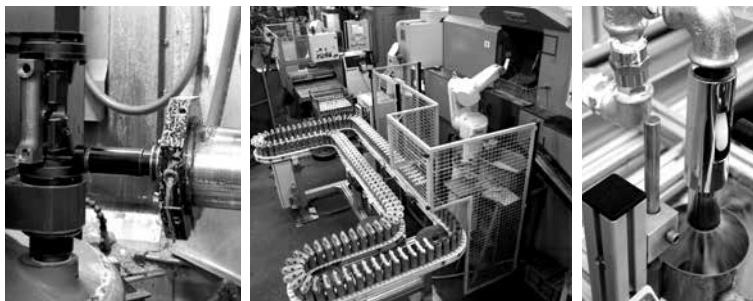

## **EN - Men build societies.**

Paini case is an example of that. Starting from a little craft made factory founded in 1954, in 50 years it has become one of the leader companies in its range. At the end of the Sixties it reached the size of a little company, in 1972 it became a joint-stock company and it was also necessary to build a more modern and equipped plant next to the one already existing. The period of wider development for the company has certainly clashed with the birth of the mixer, in the Eighties. Today Paini is a big company covering an area of about 100,000 square metres, out of which 70,000 covered, with 390 employees working in it.

The staff are highly specialised and educated also through in house refresher courses. We also offer stages to students from technical and commercial institutes. Paini offers a wide range of taps - mixers, bathroom accessories and ship-building industry, kitchen, bath and shower associated products. We proudly produce 4 million pieces per annum. The production cycle provides the usage of high quality raw materials only, in conformity with the strict UNI-CEE standards. Our Research Centre Team provides test laboratories and analysis aiming at studying and gaining experience on mechanical, chemical and functional problems. The production is completely carried out in

house utilising a wide range of modern technological production disciplines on transfer and multi-spindled machines. Quality tests are carried out during all production and handling steps, from the main to the secondary ones. To this aim computerised equipment programmed according to specific evaluation protocols for each handling are used. Final polishing of the pieces can be both robotized and manual, according to the production problems and the finish level every single piece should provide. The chromium plating plant system is one of the largest in the industry and automatically assures the chromium thickness standard in conformity with international norms.

Pieces are carried on air frames sliding on an electromechanical birail. On site we also provide colouring plants using epoxidic powder and liquid. PDV facility proves great success, enabling to get finishes of higher resistance than the traditional ones. Our products meet the international standards of several Union agencies and is one of the few Italian companies in the industry to provide IAPMO certificates, which are valid for the U.S.A. market.

*Paini*

# norme internazionali

international standards



**IT** - I prodotti Painsi sono realizzati nel rispetto delle rigorose norme internazionali che prevedono l'utilizzo di materie prime di qualità superiore, il controllo sul processo produttivo e l'analisi sul funzionamento di ogni singolo prodotto, garantendo così qualità e sicurezza.

**EN** - Painsi products are realised following the strict international rules which require the use of high quality raw materials, production process control and single product working analysis, thus granting quality and safety.





# codici finiture

finishing codes / codes finitions  
códigos acabados / ausföhrungen kode



**CR**  
CROMO  
CHROME  
CHROMÉ  
CROMO  
CHROM



**OP**  
PVD ORO  
PVD GOLD  
PVD OR  
PVD ORO  
PVD GOLD

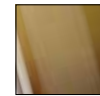

**TD**  
TERRA DI FRANCIA  
FRANCE EARTH  
TERRE DE FRANCE  
TIERRA DE FRANCIA  
FRANKREICH BODEN



**BD**  
BIANCO  
WHITE  
BLANC  
BLANCO  
WEISS



**BY**  
BIANCO OPACO  
MATT WHITE  
BLANC MAT  
BLANCO MATE  
MATT WEISS



**YO**  
NERO OPACO  
MATT BLACK  
NOIR MAT  
NEGRO MATE  
MATT SCHWARZ



**NR**  
NERO  
BLACK  
NOIR  
NEGRO  
SCHWARZ



**F3**  
OTTONE ANTICO  
AGED BRASS  
LAITON ANCIEN  
LATÓN ANTIGUO  
MESSING ANTIK



**OT**  
OTTONATO  
BRASS  
LAITON  
LATÓN  
MESSING



**QL**  
RAME ANTICO  
AGED COPPER  
CUIVRE ANCIEN  
COBRE ANTIGUO  
KUPFER ANTIK



**PW**  
PVD NICHEL ANTICO  
AGED NICKEL PVD  
PVD NICKEL ANCIEN  
PVD NÍQUEL ANTIGUO  
PVD NICKEL ANTIK

# energy saving



## G35 Energy Saving



## Green Thinking

La cartuccia **ENERGY SAVING** è intercambiabile con la cartuccia standard da 35 mm.

**ENERGY SAVING** è una tecnologia che permette di fornire solo acqua fredda con la leva posizionata nel mezzo:

- risparmiando acqua calda
- risparmiando soldi
- rispettando l'ambiente.

**ENERGY SAVING** cartridge is interchangeable with the standard 35 mm seat.

**ENERGY SAVING** is a technology that allows to supply

only cold water with the lever in middle position:

- hot water saving
- money saving
- environmental respect.



92

arena



*OPaini*

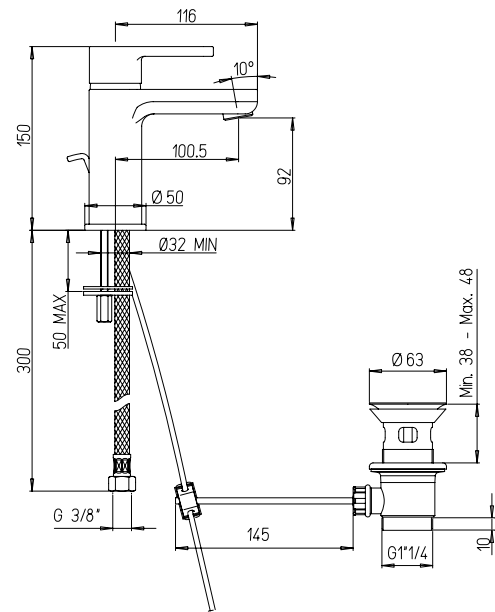

## 92CR211

Miscelatore monoforo lavabo con scarico automatico 1"1/4

Single-lever basin mixer with 1"1/4 pop-up waste

Mitigeur lavabo avec vidage automatique 1"1/4

Mezclador lavabo con desagüe automático 1"1/4

Waschtischmischer Ab- und Überlaufgarnitur 1"1/4

RICAMBI / SPARE PARTS:

**53CC956G350** CARTUCCIA / CARTRIDGE

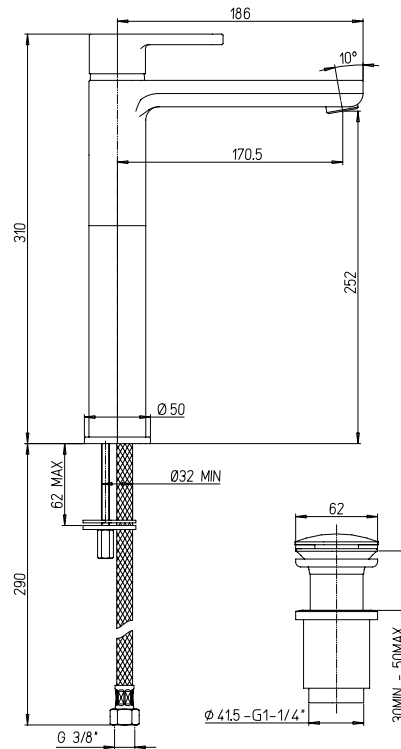

## 92CR211LLBLSSR

Miscelatore monoforo lavabo tipo alto scarico 1"1/4 simple-rapid

Single-lever basin mixer high model with simple-rapid 1"1/4 pop-up waste

Mitigeur lavabo type haut avec vidage simple-rapid 1"1/4

Mezclador lavabo alto con desagüe simple-rapid 1"1/4

Waschtischmischer hohe Ausführung simple-rapid Ab- und Überlaufgarnitur 1"1/4

RICAMBI / SPARE PARTS:

**53CC956G350** CARTUCCIA / CARTRIDGE

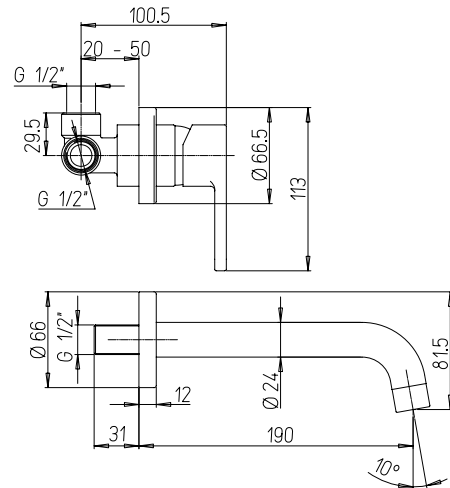

## 92CR208

**Miscelatore lavabo a muro, bocca interasse mm 190**  
 Single-lever wall mounted mixer, 190 mm spout  
**Mitigeur lavabo mural, bec 190 mm**  
 Mezclador empotrable para lavabo, caño 190 mm  
 Wand-Waschtischmischer, Auslauf 190 mm

RICAMBI / SPARE PARTS:  
**53CC956GM** CARTUCCIA / CARTRIDGE

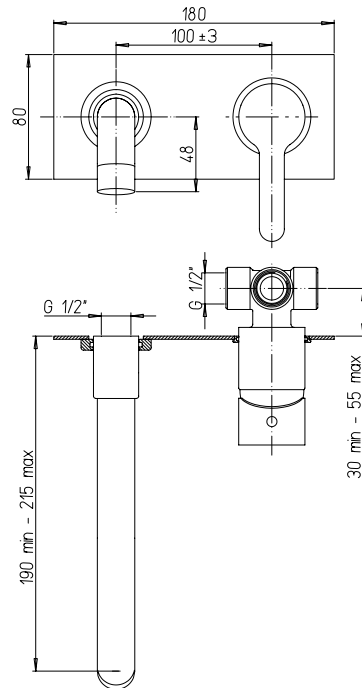

## 92CR208P

**Miscelatore lavabo a muro con piastra, bocca interasse mm 200**  
 Single-lever wall mounted mixer with plate, 200 mm spout  
**Mitigeur lavabo mural avec plaque de finition, bec 200 mm**  
 Mezclador empotrable para lavabo con plancha, caño 200 mm  
 Wand-Waschtischmischer mit Abdeckplatte, Auslauf 200 mm

RICAMBI / SPARE PARTS:  
**53CC956GM** CARTUCCIA / CARTRIDGE

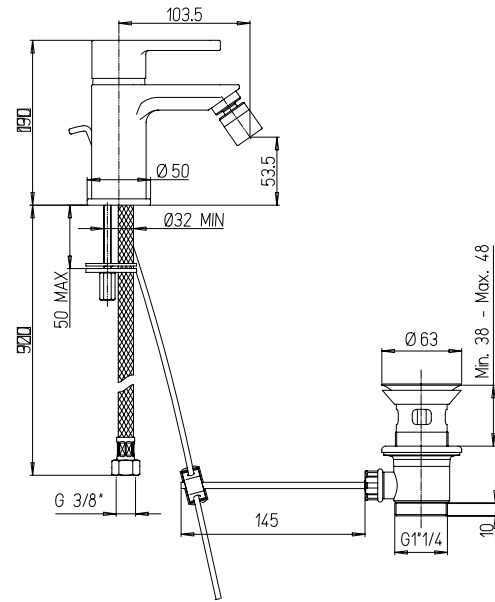

## 92CR306

**Miscelatore monoforo bidet, scarico automatico 1"1/4**  
 Single-lever bidet mixer with 1"1/4 pop-up waste  
**Mitigeur bidet avec vidage automatique 1"1/4**  
 Mezclador monomando bidé con desagüe automático 1"1/4  
 Bidetmischer Ab- und Überlaufgarnitur 1"1/4

RICAMBI / SPARE PARTS:  
**53CC956G350** CARTUCCIA / CARTRIDGE

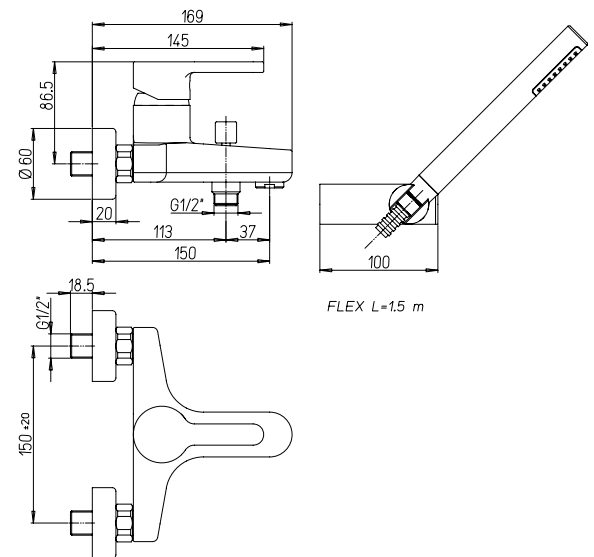

## 92CR105

**Miscelatore vasca esterno con doccia "Duplex"**  
 Single lever bath-shower mixer with adjustable shower kit  
**Mitigeur bain-douche apparent avec garniture de douche orientable**  
 Mezclador baño-ducha con equipo ducha, soporte articulado  
 Bademischer mit Brausegarnitur, Brausehalter verstellbar

RICAMBI / SPARE PARTS:  
**53CC956GM** CARTUCCIA / CARTRIDGE

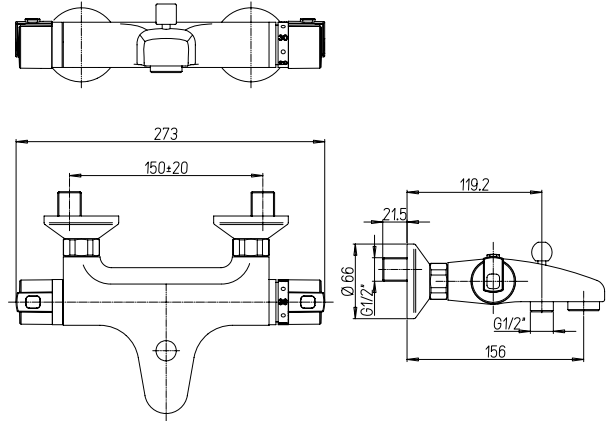

## 92CR111TH

**Gruppo vasca esterno termostatico senza "Duplex"**  
 Thermostatic bath mixer  
**Mélangeur thermostatique bain-douche mural nu**  
 Mezclador termostático para bañera  
 Thermostat-Wannenbatterie

RICAMBI / SPARE PARTS:  
**53CC956GM** CARTUCCIA / CARTRIDGE

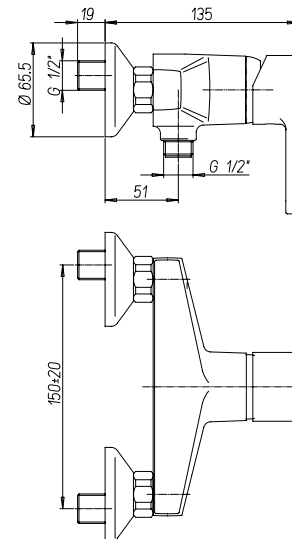

## 92CR511

**Miscelatore doccia esterno 1/2"**  
 1/2" single-lever shower mixer  
**Mitigeur douche apparent nu 1/2"**  
 Mezclador monomando ducha 1/2" sin equipo ducha  
 Brausemischer 1/2"

RICAMBI / SPARE PARTS:  
**53CC956GM** CARTUCCIA / CARTRIDGE



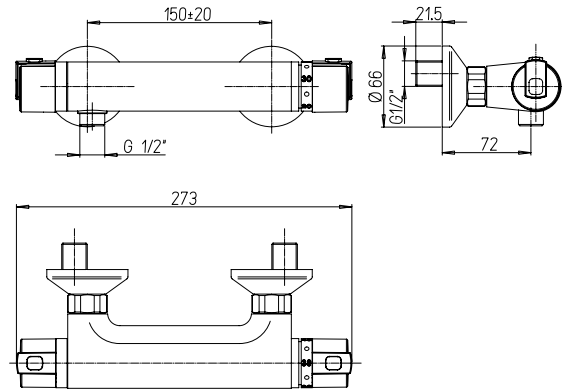

## 92CR511TH

**Gruppo doccia esterno termostatico**  
 Thermostatic shower mixer  
**Mitigeur thermostatique douche**  
 Mezclador termostático ducha  
 Thermostat-Brausemischer

RICAMBI / SPARE PARTS:  
**53CC956G350** CARTUCCIA / CARTRIDGE

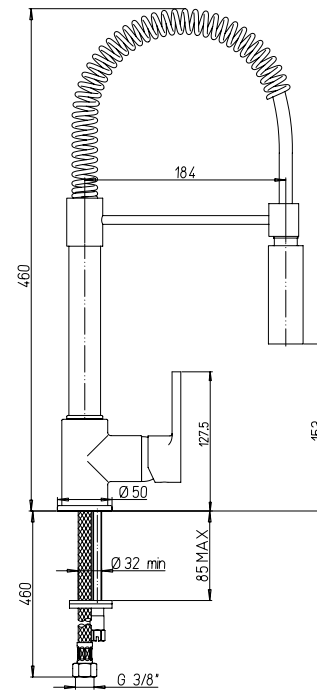

## 92CR557LLPE

**Miscelatore monoforo lavello bocca a molla con asta orientabile**  
 Single-lever kitchen mixer with spring and swivel spout  
**Mitigeur évier avec bec à ressort orientable**  
 Mezclador monomando fregadero, caño a resorte giratorio  
 Einhebelmischer mit schwenkbarem Federauslauf

RICAMBI / SPARE PARTS:  
**53CC956GM** CARTUCCIA / CARTRIDGE

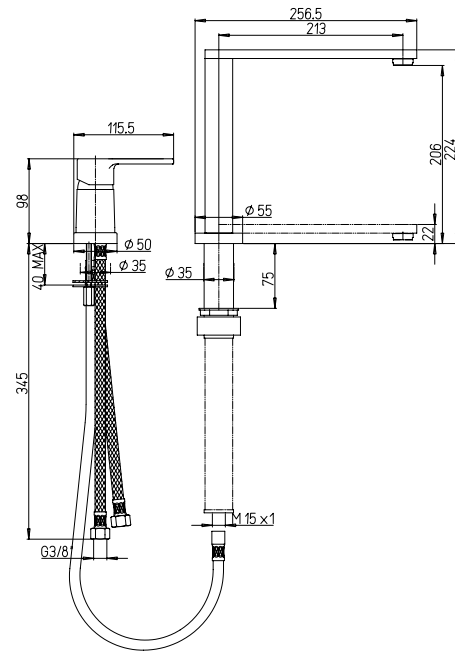

## 92CR569/5822F

Miscelatore lavello sottofinestra  
 Kitchen mixer for under window mounting  
 Mitigeur évier sous fenêtre  
 Mezclador fregadero subventana  
 Spültischmischer Unterfenster

RICAMBI / SPARE PARTS:  
**53CC956GM** CARTUCCIA / CARTRIDGE

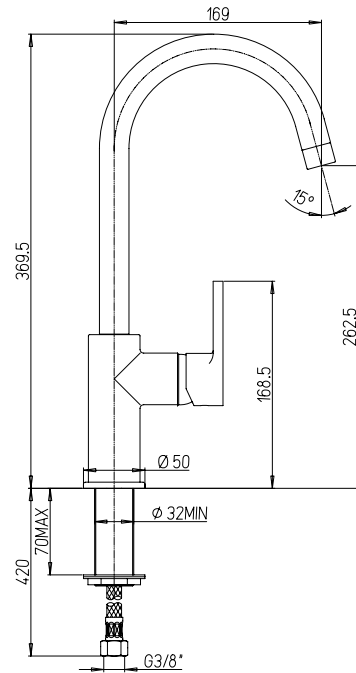

## 92CR572LL

Miscelatore monoforo lavello con bocca orientabile  
 Single-lever kitchen mixer with swivel spout  
 Mitigeur évier avec bec orientable  
 Mezclador monomando fregadero con caño giratorio  
 Spültischmischer mit schwenkbarem Auslauf

RICAMBI / SPARE PARTS:  
**53CC956GM** CARTUCCIA / CARTRIDGE

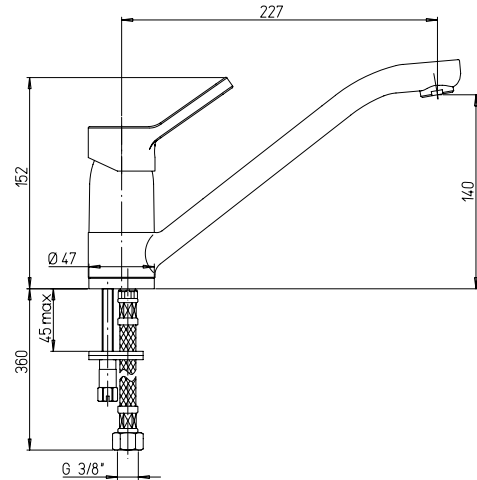

## 92CR573

**Monocomando monoforo lavello bocca coassiale**  
 Single-lever kitchen mixer with swivel spout  
**Mitigeur évier avec bec orientable**  
 Mezclador monomando fregadero, caño giratorio  
 Einhebelmischer mit schwenkbarem Auslauf

RICAMBI / SPARE PARTS:  
**53CC956GM** CARTUCCIA / CARTRIDGE

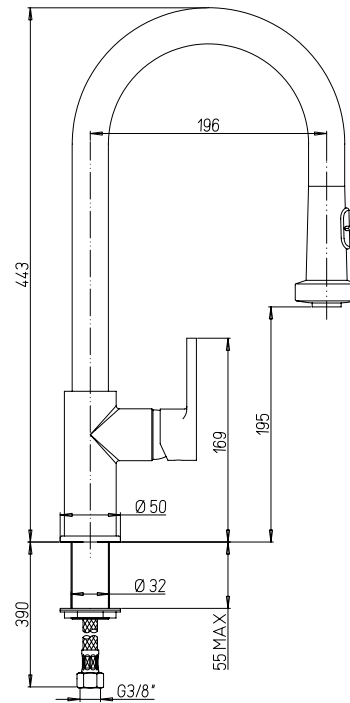

## 92CR591LL

**Monocomando monoforo lavello con doccetta monogetto estraibile**  
 Single-lever kitchen mixer with single flow pull-out shower  
**Mitigeur évier avec douchette escamotable**  
 Mezclador monomando fregadero, con ducha extraíble  
 Einhebelmischer mit herausziehbarer Handbrause

RICAMBI / SPARE PARTS:  
**53CC956GM** CARTUCCIA / CARTRIDGE

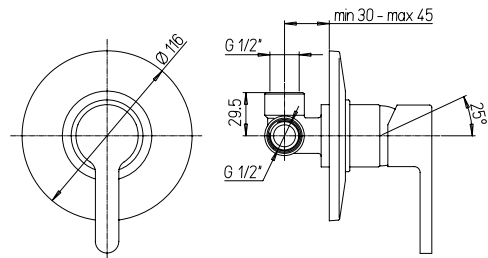

## 92CR690

**Miscelatore doccia incasso**  
 Built-in single-lever shower mixer  
**Mitigeur douche à encastrer**  
 Mezclador ducha empotrado  
 Einbau Brausebatterie

RICAMBI / SPARE PARTS:  
**53CC956GM** CARTUCCIA / CARTRIDGE

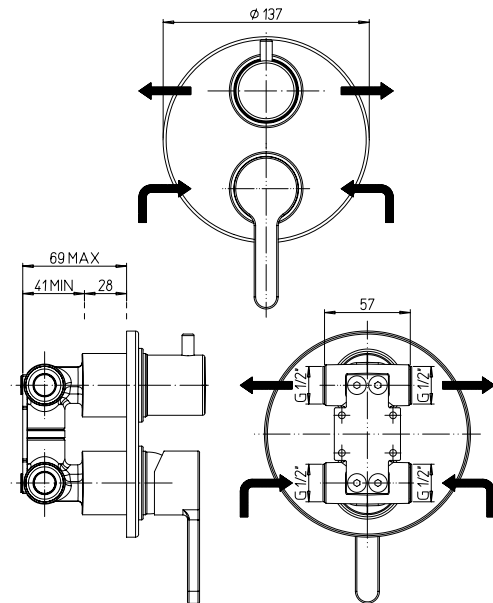

## 92CR6911

**Miscelatore doccia incasso con deviatore rotativo 2 uscite**  
 Built-in single-lever bath-shower mixer with 2-way rotary diverter valve  
**Mitigeur bain-douche à encastrer avec inverseur rotatif 2 sorties**  
 Mezclador monomando baño-ducha empotrado con desviador giratorio 2 salidas  
 Einbau Brausemischer mit Drehumsteller, 2 Wege

RICAMBI / SPARE PARTS:  
**53CC956GM** CARTUCCIA / CARTRIDGE

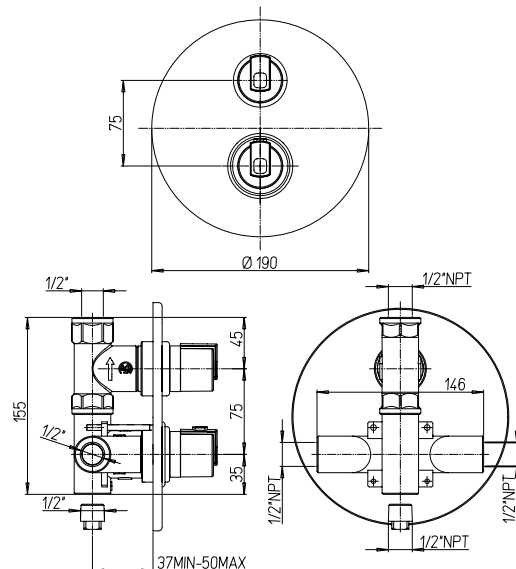

## 92CR690TH

**Gruppo doccia incasso termostatico con rubinetto di arresto**

Built-in thermostatic shower mixer with stop valve

**Mitigeur douche thermostatique à encastrer avec robinet d'arrêt**

Mezclador termostático ducha empotrado con llave de paso

**Einbau Thermostat-Brausebatterie mit Absperrventil**

RICAMBI / SPARE PARTS:

**53CC5813/4S** VITONE / HEADWORK

**2TCC959** CARTUCCIA TERMO / THERMO CARTRIDGE

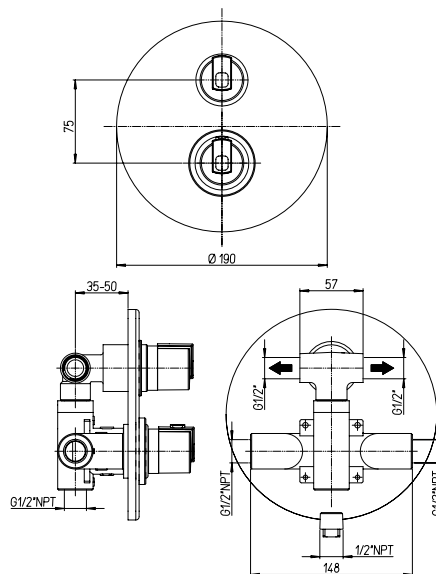

## 92CR691TH

**Gruppo doccia incasso termostatico con rubinetto di arresto e deviatore 2 uscite**

Built-in thermostatic shower mixer with stop valve and 2-way diverter

**Mitigeur douche thermostatique à encastrer avec robinet d'arrêt et inverseur 2 voies**

Mezclador termostático ducha empotrado con llave de paso e inversor 2 vías

**Einbau Thermostat-Brausemischer mit Absperrventil und 2-Wege Umsteller**

RICAMBI / SPARE PARTS:

**53CC956DEV35** CARTUCCIA / CARTRIDGE

**2TCC959** CARTUCCIA TERMO / THERMO CARTRIDGE

# 80

# cooper



Cartuccia con limitatore di portata  
al 50% e limitazione della temperatura  
Cartridge with 50% water saving and anti scald system.

*OPaini*

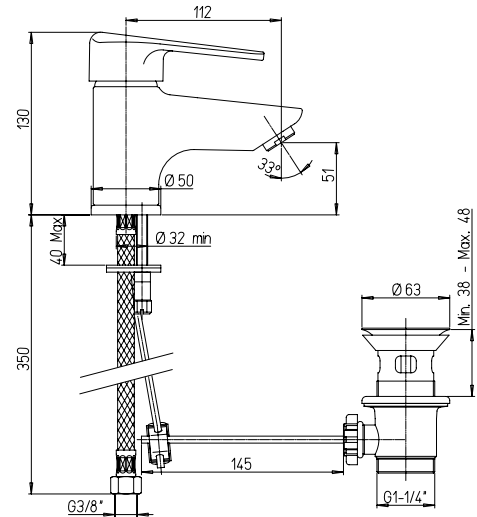

## 80CR211

Miscelatore monoforo lavabo con scarico automatico 1"1/4  
 Single-lever basin mixer with 1"1/4 pop-up waste  
 Mitigeur lavabo avec vidage automatique 1"1/4  
 Mezclador lavabo con desagüe automático 1"1/4  
 Waschtischmischer Ab- und Überlaufgarnitur 1"1/4

RICAMBI / SPARE PARTS:  
**53CC956G40D2S** CARTUCCIA / CARTRIDGE

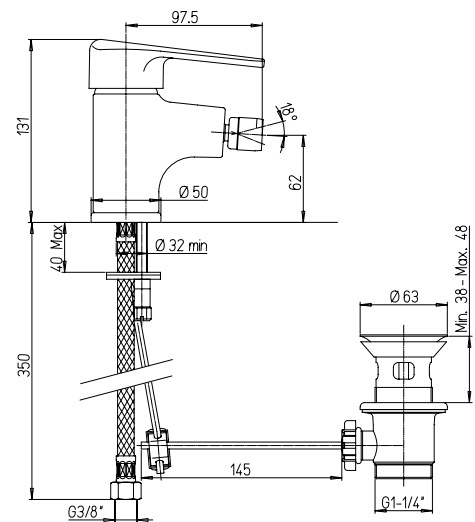

## 80CR306

Miscelatore monoforo bidet, scarico automatico 1"1/4  
 Single-lever bidet mixer with 1"1/4 pop-up waste  
 Mitigeur bidet avec vidage automatique 1"1/4  
 Mezclador monomando bidé con desagüe automático 1"1/4  
 Bidetmischer Ab- und Überlaufgarnitur 1"1/4

RICAMBI / SPARE PARTS:  
**53CC956G40D2S** CARTUCCIA / CARTRIDGE

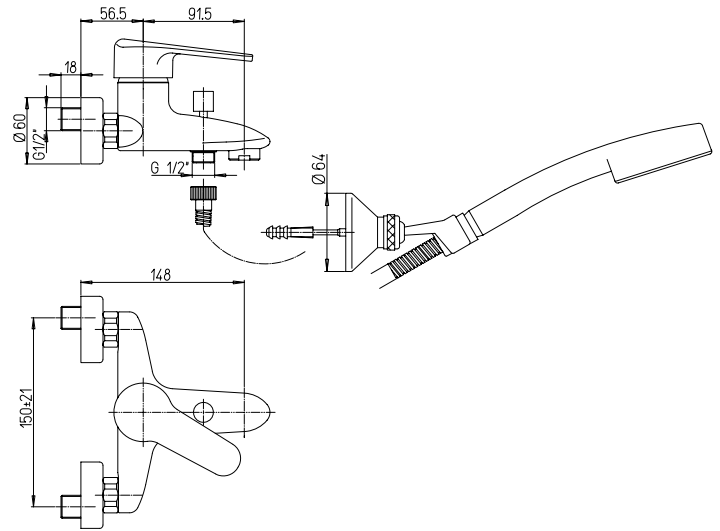

## 80CR105

Miscelatore vasca esterno con doccia "Duplex"

Single lever bath-shower mixer with adjustable shower kit

Mitigeur bain-douche apparent avec garniture de douche orientable

Mezclador monomando baño-ducha mural con equipo ducha, soporte articulado

Bademischer mit Brausegarnitur, Brausehalter verstellbar

RICAMBI / SPARE PARTS:

**53CC956G40D2S** CARTUCCIA / CARTRIDGE

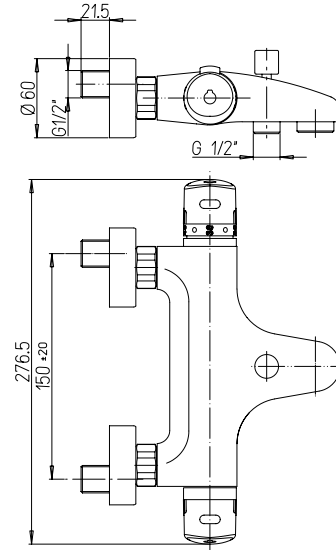

## 80CR111TH

Gruppo vasca esterno termostatico senza "Duplex"

Thermostatic bath mixer

Mélangeur thermostatique bain-douche mural nu

Mezclador termostático para bañera

Thermostat-Wannenbatterie

RICAMBI / SPARE PARTS:

**53CR581ZD** VITONE / HEADWORK

**2TCC959** CARTUCCIA TERMO / THERMO CARTRIDGE



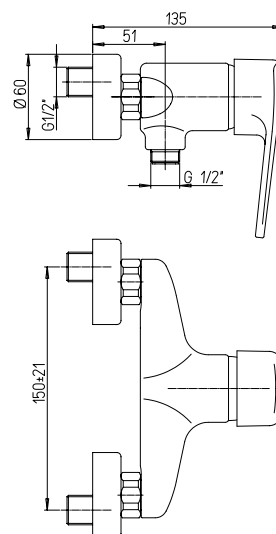

## 80CR511

**Miscelatore doccia esterno 1/2"**

1/2" single-lever shower mixer

**Mitigeur douche apparent nu 1/2"**

Mezclador monomando ducha 1/2" sin equipo ducha

**Brausemischer 1/2"**

RICAMBI / SPARE PARTS:

**53CC956G40D2S** CARTUCCIA / CARTRIDGE

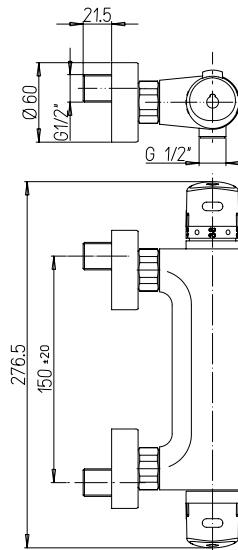

## 80CR511TH

**Gruppo doccia esterno termostatico**

Thermostatic shower mixer

**Mitigeur thermostatique douche**

Mezclador termostático ducha

**Thermostat-Brausemischer**

RICAMBI / SPARE PARTS:

**53CR581ZD** VITONE / HEADWORK

**2TCC959** CARTUCCIA TERMO / THERMO CARTRIDGE

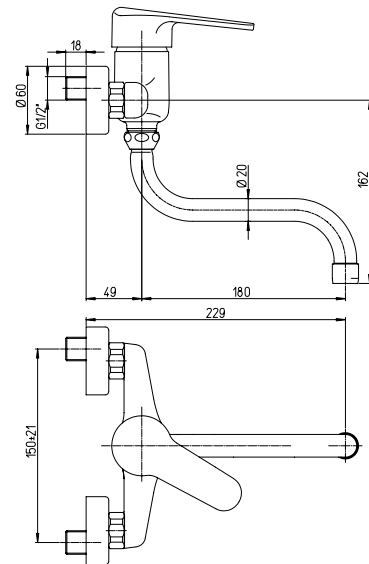

## 80CR501

**Monocomando lavello a muro**  
 Wall mounted single-lever kitchen mixer  
**Mittigeur évier mural**  
 Mezclador fregadero exterior  
 Wand-Spültischmischer

RICAMBI / SPARE PARTS:  
**53CC956G40D2S** CARTUCCIA / CARTRIDGE

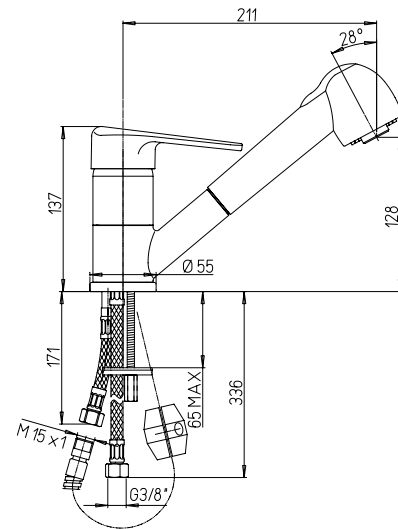

## 80CR568

**Miscelatore monoforo lavello con doccia estraibile**  
 Single-lever kitchen mixer with pull-out spray  
**Mittigeur monotrou évier avec douchette escamotable**  
 Mezclador monomando fregadero con ducha extraíble  
 Spültischmischer mit herausziehbarer Handbrause

RICAMBI / SPARE PARTS:  
**53CC956G40D2S** CARTUCCIA / CARTRIDGE



## 80CR572

Miscelatore monoforo lavello con bocca orientabile  
 Single-lever kitchen mixer with swivel spout  
 Mitigeur évier avec bec orientable  
 Mezclador monomando fregadero con caño giratorio  
 Spültischmischer mit schwenkbarem Auslauf

RICAMBI / SPARE PARTS:  
**53CC956G40D2S** CARTUCCIA / CARTRIDGE

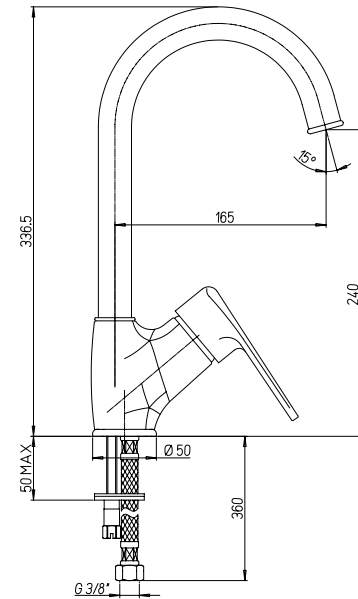

## 80CR583

Monocomando monoforo lavello bocca coassiale  
 Single-lever kitchen mixer with swivel spout  
 Mitigeur évier avec bec orientable  
 Mezclador monomando fregadero, caño giratorio  
 Einhebelmischer mit schwenkbarem Auslauf

RICAMBI / SPARE PARTS:  
**53CC956G40D2S** CARTUCCIA / CARTRIDGE

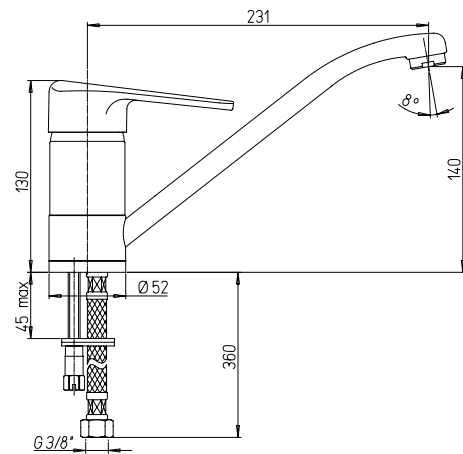

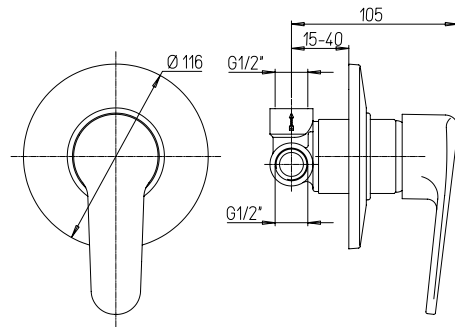

## 80CR690

**Miscelatore doccia incasso**  
 Built-in single-lever shower mixer  
**Mitigeur douche à encastrer**  
 Mezclador ducha empotrado  
 Einbau Brausebatterie

RICAMBI / SPARE PARTS:  
**53CC956G40D2S** CARTUCCIA / CARTRIDGE

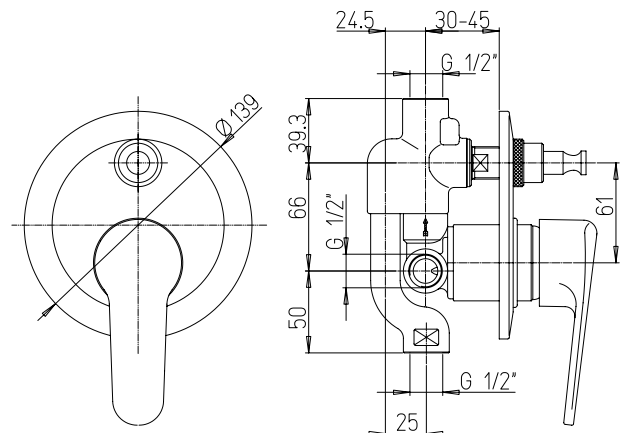

## 80CR691

**Miscelatore doccia incasso con deviatore**  
 Built-in single-lever bath-shower mixer with diverter  
**Mitigeur bain-douche à encastrer avec inverseur**  
 Mezclador monomando baño-doucha empotrado  
 Einbau Brausemischer mit Umschalter

RICAMBI / SPARE PARTS:  
**53CC956G40D2S** CARTUCCIA / CARTRIDGE



42

creta 100



*ÓPaini*

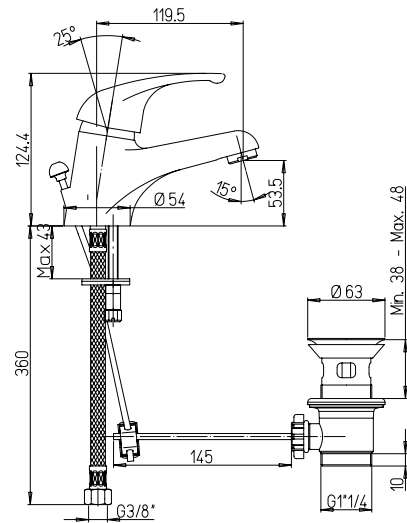

## 42CR211

Miscelatore monoforo lavabo con scarico automatico 1"1/4  
 Single-lever basin mixer with 1"1/4 pop-up waste  
 Mitigeur lavabo avec vidage automatique 1"1/4  
 Mezclador lavabo con desagüe automático 1"1/4  
 Waschtischmischer Ab- und Überlaufgarnitur 1"1/4

RICAMBI / SPARE PARTS:  
**53CC956G40DAP** CARTUCCIA / CARTRIDGE

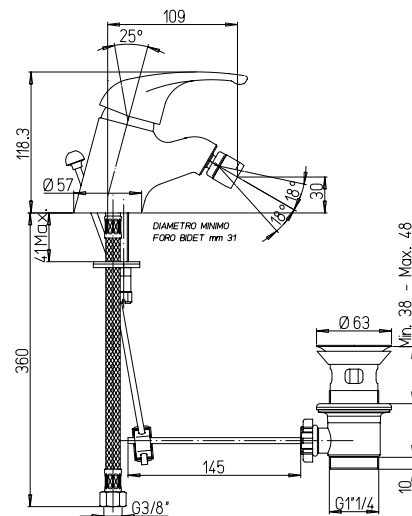
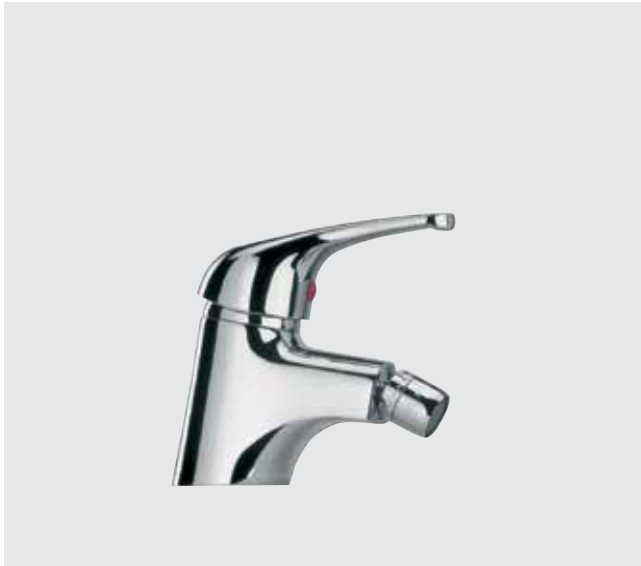

## 42CR306

Miscelatore monoforo bidet, scarico automatico 1"1/4  
 Single-lever bidet mixer with 1"1/4 pop-up waste  
 Mitigeur bidet avec vidage automatique 1"1/4  
 Mezclador monomando bidé con desagüe automático 1"1/4  
 Bidetmischer Ab- und Überlaufgarnitur 1"1/4

RICAMBI / SPARE PARTS:  
**53CC956G40DAP** CARTUCCIA / CARTRIDGE

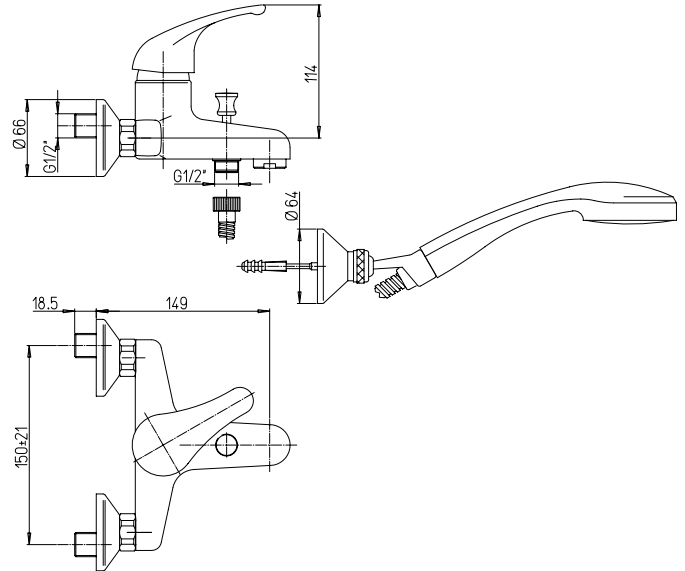

## 42CR105

### Miscelatore vasca esterno con doccia "Duplex"

Single lever bath-shower mixer with adjustable shower kit

### Mitigeur bain-douche apparent avec garniture de douche orientable

Mezclador monomando baño-ducha mural con equipo ducha, soporte articulado

Bademischer mit Brausegarnitur, Brausehalter verstellbar

RICAMBI / SPARE PARTS:

**53CC956G40DAP** CARTUCCIA / CARTRIDGE

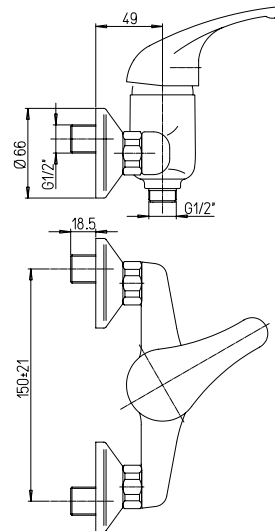

## 42CR511

### Miscelatore doccia esterno 1/2"

1/2" single-lever shower mixer

### Mitigeur douche apparent nu 1/2"

Mezclador monomando ducha 1/2" sin equipo ducha

Brausemischer 1/2"

RICAMBI / SPARE PARTS:

**53CC956G40DAP** CARTUCCIA / CARTRIDGE



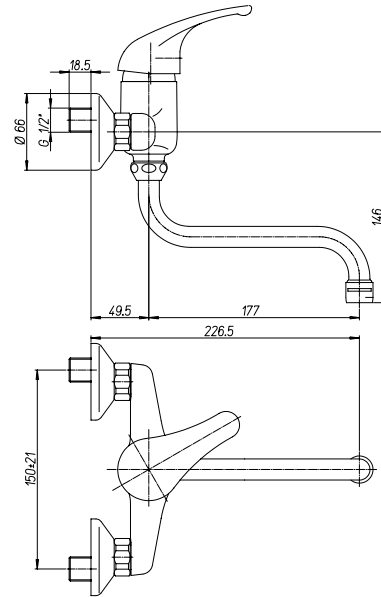

## 42CR501

**Monocomando lavello a muro**  
 Wall mounted single-lever kitchen mixer  
**Mitigeur évier mural**  
 Mezclador fregadero exterior  
**Wand-Spültischmischer**

RICAMBI / SPARE PARTS:  
**53CC956G40DAP** CARTUCCIA / CARTRIDGE

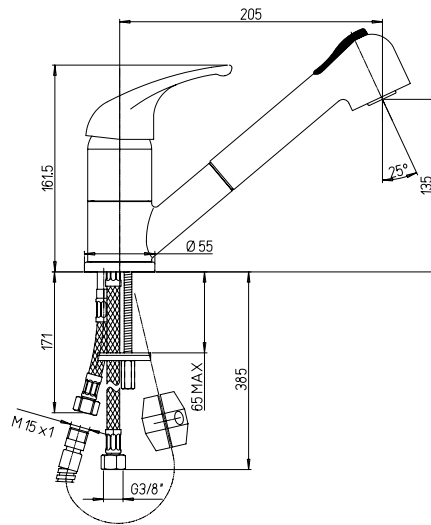

## 42CR568

**Miscelatore monoforo lavello con doccia estraibile**  
 Single-lever kitchen mixer with pull-out spray  
**Mitigeur monotrou évier avec douchette escamotable**  
 Mezclador monomando fregadero con ducha extraíble  
**Spültischmischer mit herausziehbarer Handbrause**

RICAMBI / SPARE PARTS:  
**53CC956G40AP** CARTUCCIA / CARTRIDGE

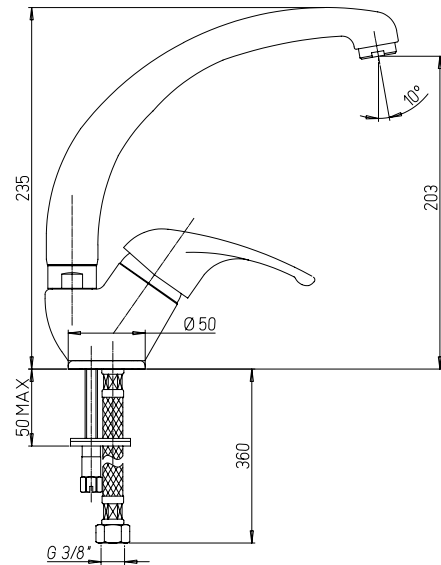

## 42CR571

**Monocomando monoforo lavello con bocca fusa orientabile**

Single-lever kitchen mixer with swivel cast spout

**Mitigeur évier bec fondu orientable**

Mezclador fregadero con caño fundido giratorio

Einloch-Spültischmischer mit schwenkbarem Gussauslauf

RICAMBI / SPARE PARTS:

**53CC956G40AP** CARTUCCIA / CARTRIDGE

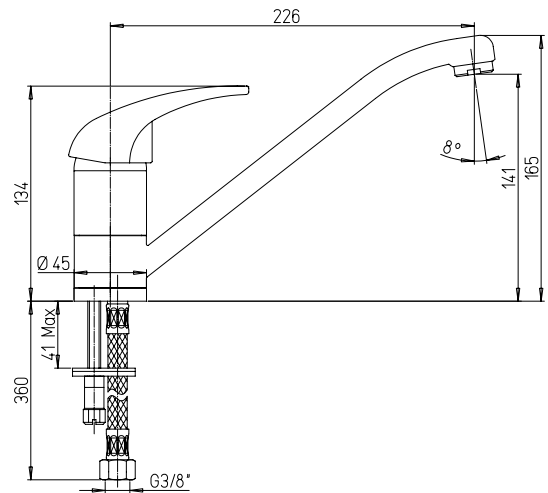

## 42CR573

**Monocomando monoforo lavello bocca coassiale**

Single-lever kitchen mixer with swivel spout

**Mitigeur évier avec bec orientable**

Mezclador monomando fregadero, caño giratorio

Einhebelmischer mit schwenkbarem Auslauf

RICAMBI / SPARE PARTS:

**53CC956G40AP** CARTUCCIA / CARTRIDGE

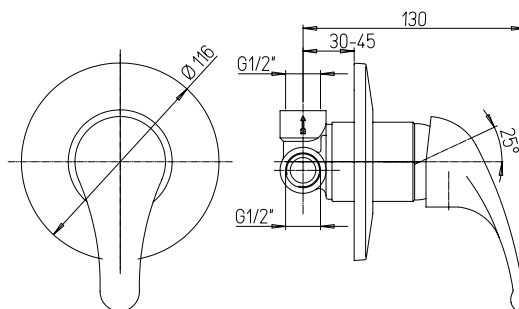
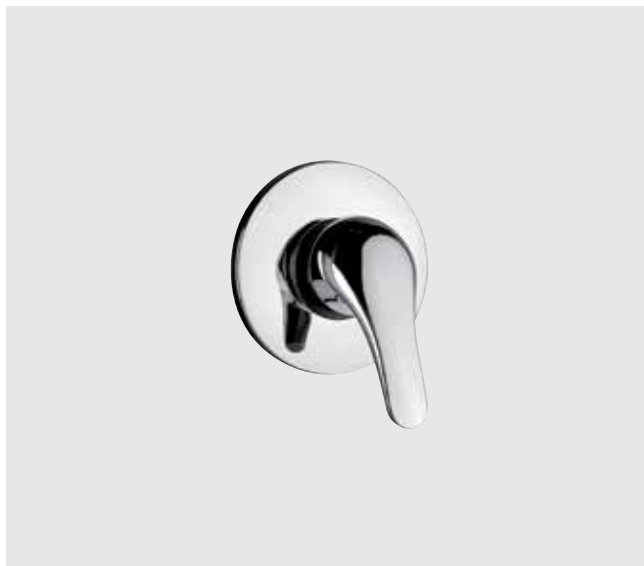

## 42CR690

**Miscelatore doccia incasso**  
 Built-in single-lever shower mixer  
**Mitigeur douche à encastrer**  
 Mezclador ducha empotrado  
 Einbau Brausebatterie

RICAMBI / SPARE PARTS:  
**53CC956G40DAP** CARTUCCIA / CARTRIDGE

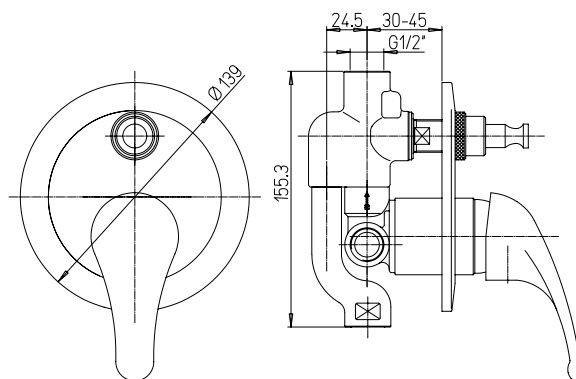
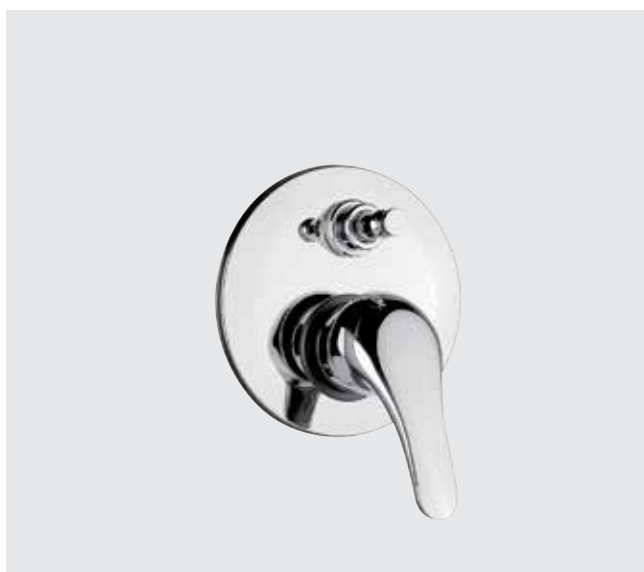

## 42CR691

**Miscelatore doccia incasso con deviatore**  
 Built-in single-lever bath-shower mixer with diverter  
**Mitigeur bain-douche à encastrer avec inverseur**  
 Mezclador monomando baño-doucha empotrado  
 Einbau Brausemischer mit Umschalter

RICAMBI / SPARE PARTS:  
**53CC956G40DAP** CARTUCCIA / CARTRIDGE

SM

smart



ENERGY  
saving 

*ÓPaini*

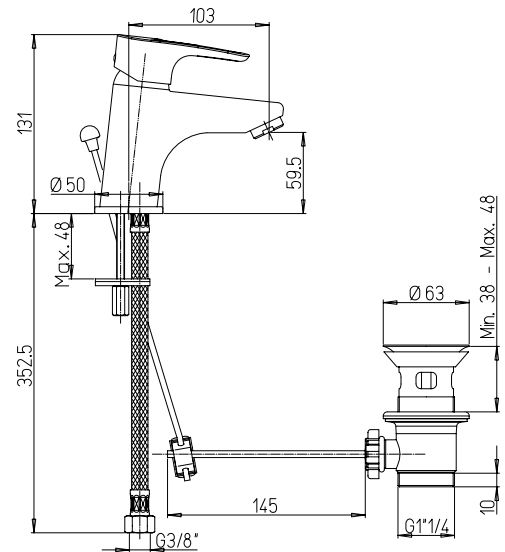

## SMCR211

Miscelatore monoforo lavabo con scarico automatico 1"1/4  
 Single-lever basin mixer with 1"1/4 pop-up waste  
 Mitigeur lavabo avec vidage automatique 1"1/4  
 Mezclador lavabo con desagüe automático 1"1/4  
 Waschtischmischer Ab- und Überlaufgarnitur 1"1/4

RICAMBI / SPARE PARTS:  
**53CC956G35DEP** CARTUCCIA / CARTRIDGE

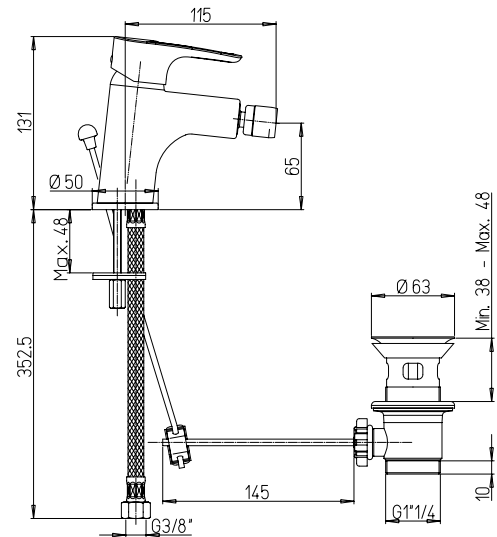

## SMCR306

Miscelatore monoforo bidet, scarico automatico 1"1/4  
 Single-lever bidet mixer with 1"1/4 pop-up waste  
 Mitigeur bidet avec vidage automatique 1"1/4  
 Mezclador monomando bidé con desagüe automático 1"1/4  
 Bidetmischer Ab- und Überlaufgarnitur 1"1/4

RICAMBI / SPARE PARTS:  
**53CC956G35DEP** CARTUCCIA / CARTRIDGE

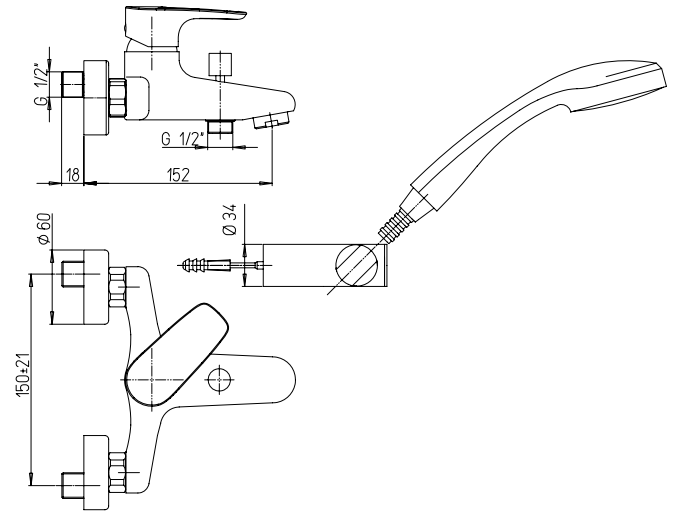

## SMCR105

**Miscelatore vasca esterno con doccia "Duplex"**

Single lever bath-shower mixer with adjustable shower kit

**Mitigeur bain-douche apparent avec garniture de douche orientable**

Mezclador monomando baño-ducha mural con equipo ducha, soporte articulado

**Bademischer mit Brausegarnitur, Brausehalter verstellbar**

RICAMBI / SPARE PARTS:

**53CC956GMD** CARTUCCIA / CARTRIDGE

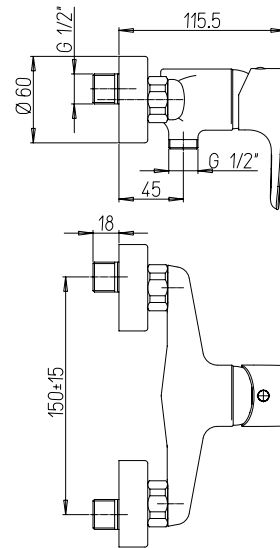

## SMCR511V

**Miscelatore doccia esterno 1/2"**

1/2" single-lever shower mixer

**Mitigeur douche apparent nu 1/2"**

Mezclador monomando ducha 1/2" sin equipo ducha

**Brausemischer 1/2"**

RICAMBI / SPARE PARTS:

**53CC956GMD** CARTUCCIA / CARTRIDGE

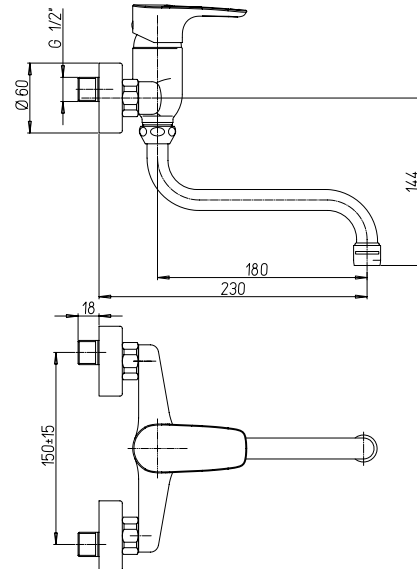

## SMCR501

Monocomando lavello a muro  
 Wall mounted single-lever kitchen mixer  
 Mitigeur évier mural  
 Mezclador fregadero exterior  
 Wand-Spültischmischer

RICAMBI / SPARE PARTS:  
**53CC956GMD** CARTUCCIA / CARTRIDGE

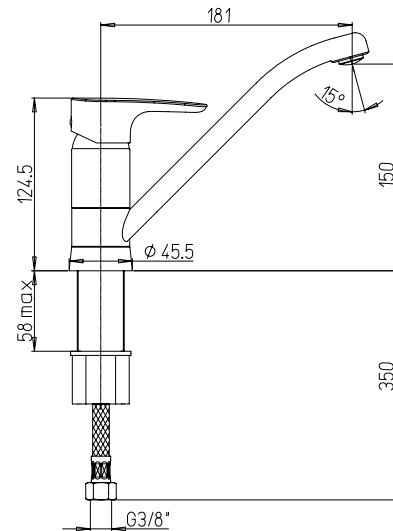

## SMCR583P



Monocomando monoforo lavello bocca coassiale  
 Single-lever kitchen mixer with swivel spout  
 Mitigeur évier avec bec orientable  
 Mezclador monomando fregadero, caño giratorio  
 Einhebelmischer mit schwenkbarem Auslauf

RICAMBI / SPARE PARTS:  
**53CC956G35EP** CARTUCCIA / CARTRIDGE

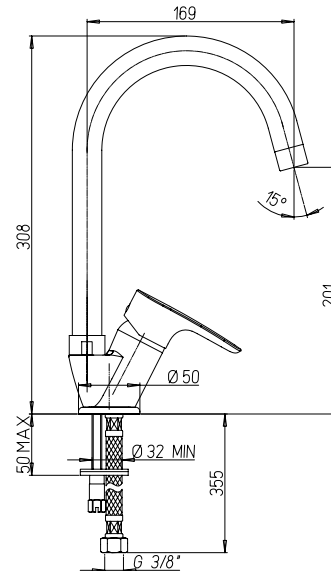

## SMCR570P

**Monocomando monoforo lavello con bocca tubo orientabile**

Single-lever kitchen mixer with swivel tube spout

**Mitigeur évier bec tube orientable**

Mezclador fregadero con caño tubular giratorio

Einloch-Spültischmischer mit schwenkbarem Rohrauslauf

RICAMBI / SPARE PARTS:

**53CC956GMD** CARTUCCIA / CARTRIDGE

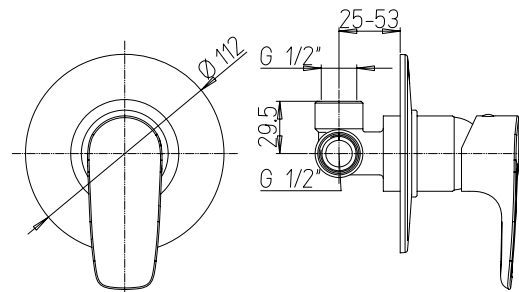

## SMCR690

**Miscelatore doccia incasso**

Built-in single-lever shower mixer

**Mitigeur douche à encastrer**

Mezclador ducha empotrado

Einbau Brausebatterie

RICAMBI / SPARE PARTS:

**53CC956GM** CARTUCCIA / CARTRIDGE



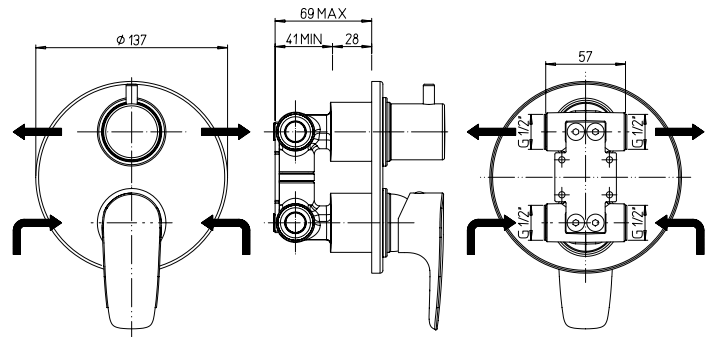

## SMCR6911

Miscelatore doccia incasso con deviatore rotativo 2 uscite

Built-in single-lever bath-shower mixer with 2-way rotary diverter valve

Mitigeur bain-douche à encastrer avec inverseur rotatif 2 sorties

Mezclador monomando baño-ducha empotrado con desviador giratorio 2 salidas

Einbau Brausemischer mit Drehumsteller, 2 Wege

RICAMBI / SPARE PARTS:

**53CC956GM** CARTUCCIA / CARTRIDGE

SH

smart  
medical



*ÓPaini*

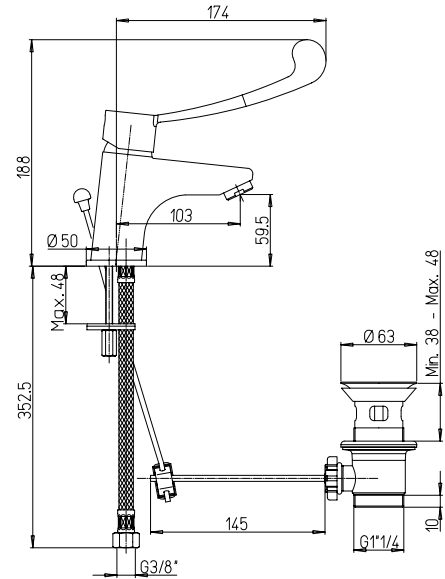

## SHCR211

Miscelatore monoforo lavabo con scarico automatico 1"1/4  
 Single-lever basin mixer with 1"1/4 pop-up waste  
 Mitigeur lavabo avec vidage automatique 1"1/4  
 Mezclador lavabo con desagüe automático 1"1/4  
 Waschtischmischer Ab- und Überlaufgarnitur 1"1/4

RICAMBI / SPARE PARTS:  
**53CC956G35DEP** CARTUCCIA / CARTRIDGE

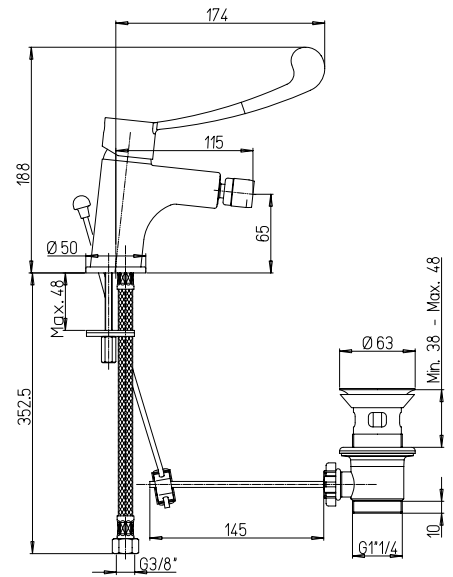

## SHCR306

Miscelatore monoforo bidet, scarico automatico 1"1/4  
 Single-lever bidet mixer with 1"1/4 pop-up waste  
 Mitigeur bidet avec vidage automatique 1"1/4  
 Mezclador monomando bidé con desagüe automático 1"1/4  
 Bidetmischer Ab- und Überlaufgarnitur 1"1/4

RICAMBI / SPARE PARTS:  
**53CC956G35DEP** CARTUCCIA / CARTRIDGE

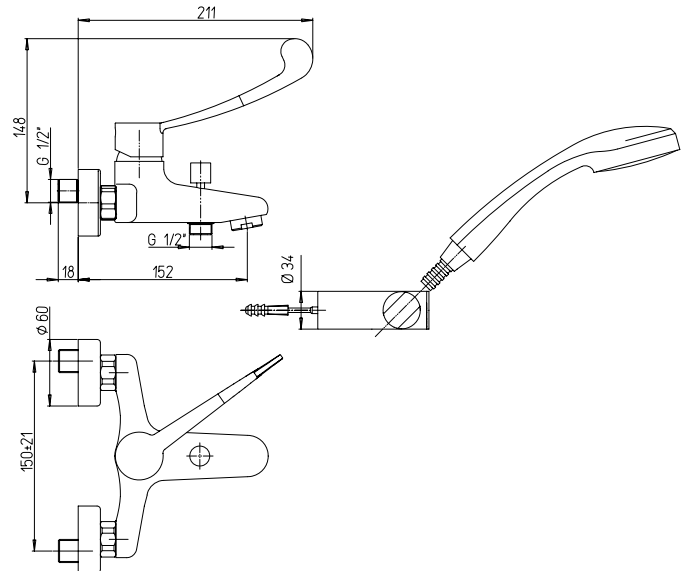

## SHCR105

**Miscelatore vasca esterno con doccia "Duplex"**

Single lever bath-shower mixer with adjustable shower kit

**Mitigeur bain-douche apparent avec garniture de douche orientable**

Mezclador monomando baño-ducha mural con equipo ducha, soporte articulado

**Bademischer mit Brausegarnitur, Brausehalter verstellbar**

RICAMBI / SPARE PARTS:

**53CC956GMD** CARTUCCIA / CARTRIDGE

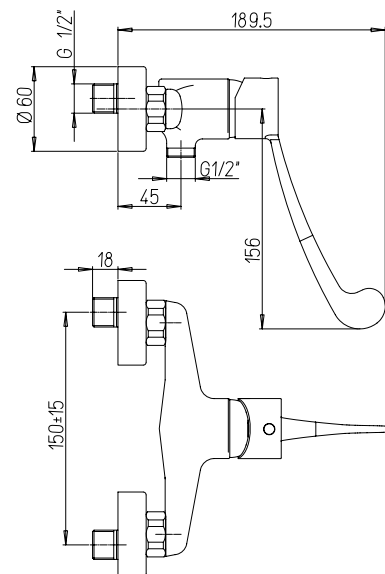

## SHCR511V

**Miscelatore doccia esterno 1/2"**

1/2" single-lever shower mixer

**Mitigeur douche apparent nu 1/2"**

Mezclador monomando ducha 1/2" sin equipo ducha

**Brausemischer 1/2"**

RICAMBI / SPARE PARTS:

**53CC956GMD** CARTUCCIA / CARTRIDGE

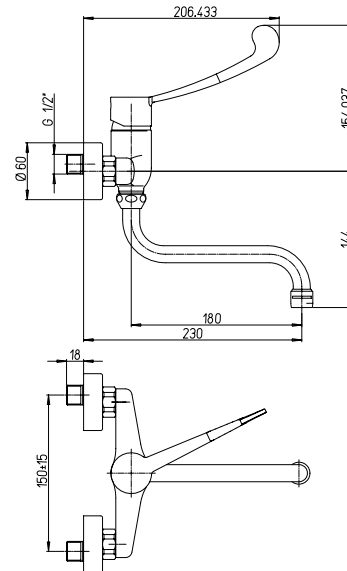

## SHCR501

Monocomando lavello a muro  
 Wall mounted single-lever kitchen mixer  
 Mitigeur évier mural  
 Mezclador fregadero exterior  
 Wand-Spültischmischer

RICAMBI / SPARE PARTS:  
**53CC956GMD** CARTUCCIA / CARTRIDGE

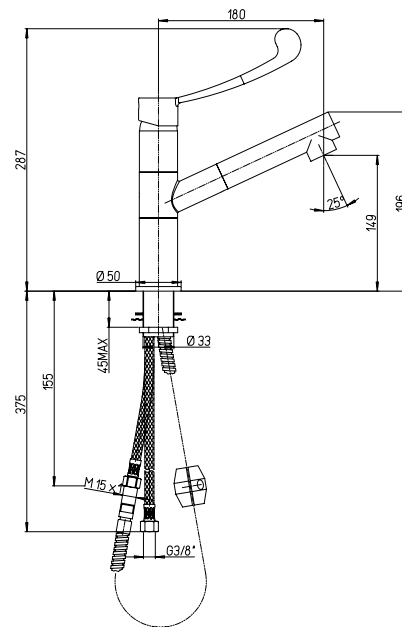

## SHCR568

Miscelatore monoforo lavello con doccia estraibile  
 Single-lever kitchen mixer with pull-out spray  
 Mitigeur monotrou évier avec douchette escamotable  
 Mezclador monomando fregadero con ducha extraíble  
 Spültischmischer mit herausziehbarer Handbrause

RICAMBI / SPARE PARTS:  
**53CC956GM** CARTUCCIA / CARTRIDGE

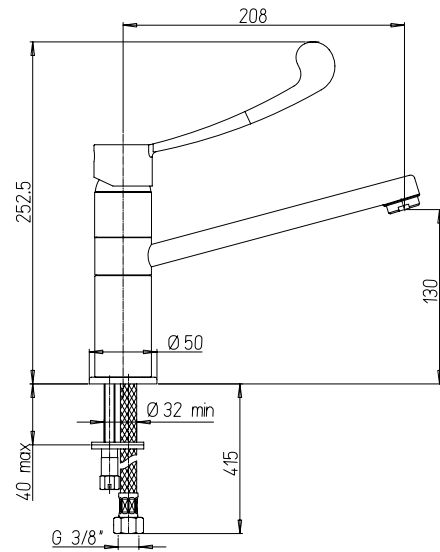

## SHCR573

**Monocomando monoforo livello bocca coassiale**  
 Single-lever kitchen mixer with swivel spout  
**Mitigeur évier avec bec orientable**  
 Mezclador monomando fregadero, caño giratorio  
 Einhebelmischer mit schwenkbarem Auslauf

RICAMBI / SPARE PARTS:  
**53CC956G35EP** CARTUCCIA / CARTRIDGE

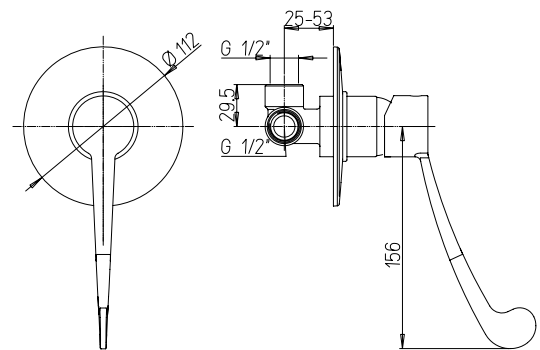

## SHCR690

**Miscelatore doccia incasso**  
 Built-in single-lever shower mixer  
**Mitigeur douche à encastrer**  
 Mezclador ducha empotrado  
 Einbau Brausebatterie

RICAMBI / SPARE PARTS:  
**53CC956GM** CARTUCCIA / CARTRIDGE

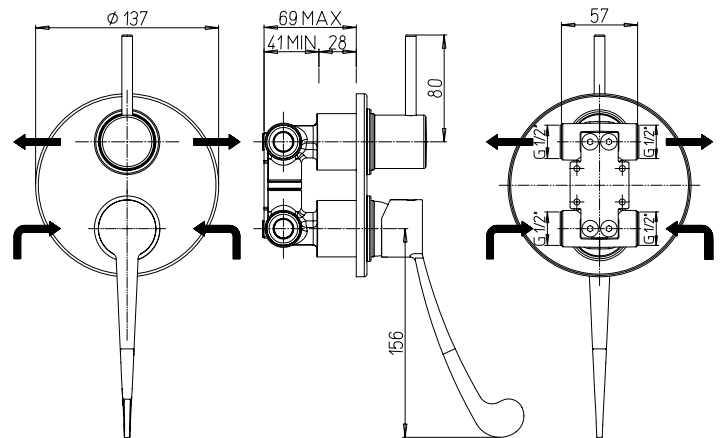

## SHCR6911

**Miscelatore doccia incasso con deviatore rotativo 2 uscite**

Built-in single-lever bath-shower mixer with 2-way rotary diverter valve

**Mitigeur bain-douche à encastrer avec inverseur rotatif 2 sorties**

Mezclador monomando baño-ducha empotrado con desviador giratorio 2 salidas

**Einbau Brausemischer mit Drehumsteller, 2 Wege**

RICAMBI / SPARE PARTS:

**53CC956GM** CARTUCCIA / CARTRIDGE

45

**mixo TC**



*ÓPaini*



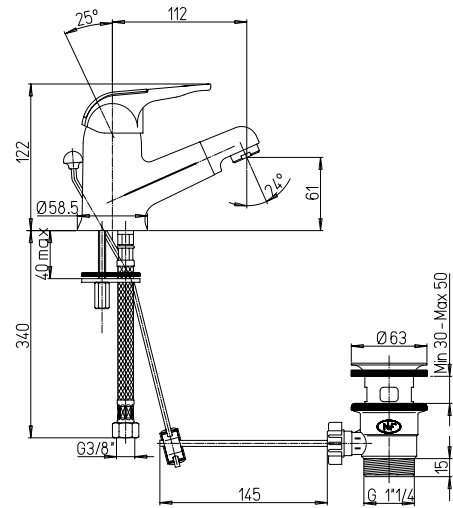

## 45CR211TC

Miscelatore monoforo lavabo, scarico automatico 1"1/4

Single-lever basin mixer with 1"1/4 pop-up waste

Mitigeur lavabo avec vidage automatique 1"1/4

Mezclador lavabo con desagüe automático 1"1/4

Waschtischmischer Ab- und Überlaufgarnitur 1"1/4

RICAMBI / SPARE PARTS:

**53CC956GM** CARTUCCIA / CARTRIDGE

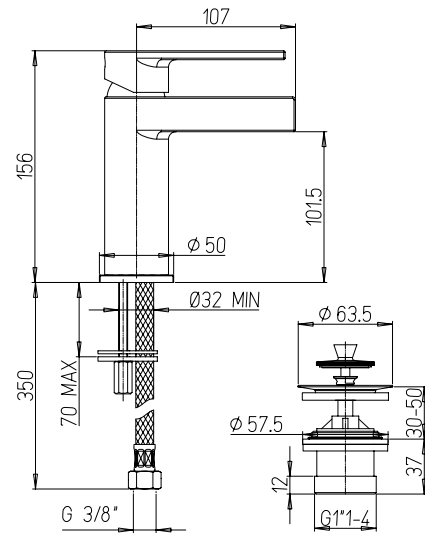

## 45CR211WFPFR

Miscelatore monoforo lavabo con piletta clic-clac 1"1/4

Single lever basin mixer with 1"1/4 clic clac waste

Mitigeur lavabo avec vidage clic clac 1"1/4

Mezclador monomando lavabo, desagüe 1"1/4 con tapon click-clack

Waschtischmischer mit Ab- und Überlaufgarnitur Clic Clac 1"1/4

RICAMBI / SPARE PARTS:

**53CC956G25** CARTUCCIA / CARTRIDGE

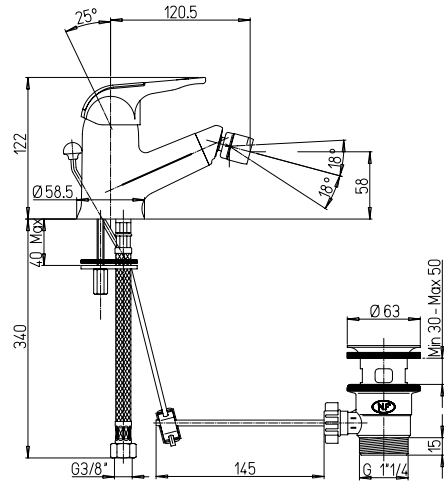

## 45CR306TC

**Miscelatore monoforo bidet, scarico automatico 1"1/4**  
 Single-lever bidet mixer with 1"1/4 pop-up waste  
**Mitigeur bidet avec vidage automatique 1"1/4**  
 Mezclador monomando bidé con desagüe automático 1"1/4  
**Bidetmischer Ab- und Überlaufgarnitur 1"1/4**

RICAMBI / SPARE PARTS:  
**53CC956GM** CARTUCCIA / CARTRIDGE

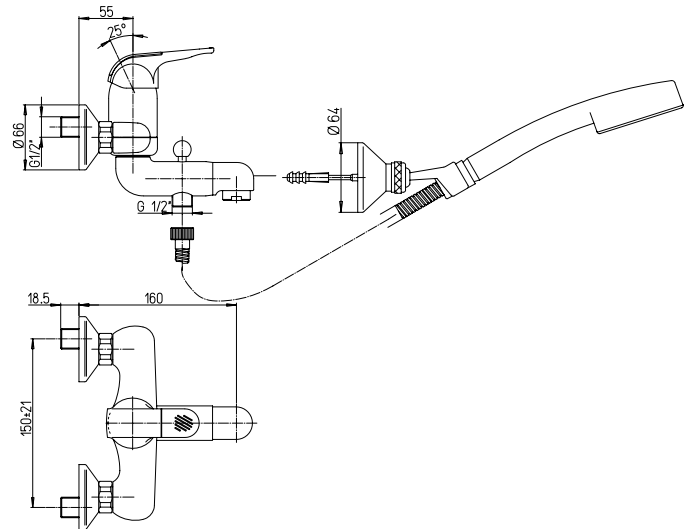

## 45CR105TC

**Miscelatore vasca esterno con doccia "Duplex"**  
 Single lever bath-shower mixer with adjustable shower kit  
**Mitigeur bain-douche apparent avec garniture de douche orientable**  
 Mezclador monomando baño-ducha mural con equipo ducha, soporte articulado  
**Bademischer mit Brausegarnitur, Brausehalter verstellbar**

RICAMBI / SPARE PARTS:  
**53CC956GM** CARTUCCIA / CARTRIDGE

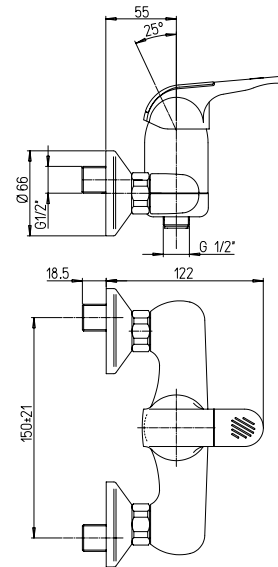

## 45CR511TC

Miscelatore doccia esterno 1/2"

1/2" single-lever shower mixer

Mitigeur douche apparent nu 1/2"

Mezclador monomando ducha 1/2" sin equipo ducha

Brausemischer 1/2"

RICAMBI / SPARE PARTS:

**53CC956GM** CARTUCCIA / CARTRIDGE

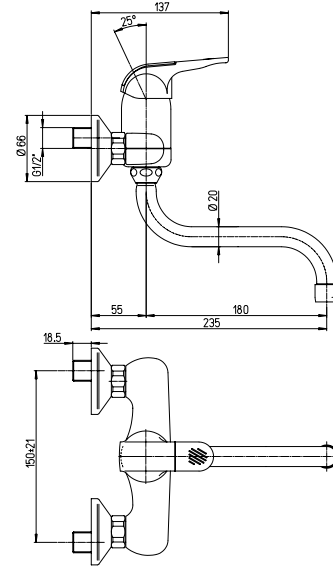
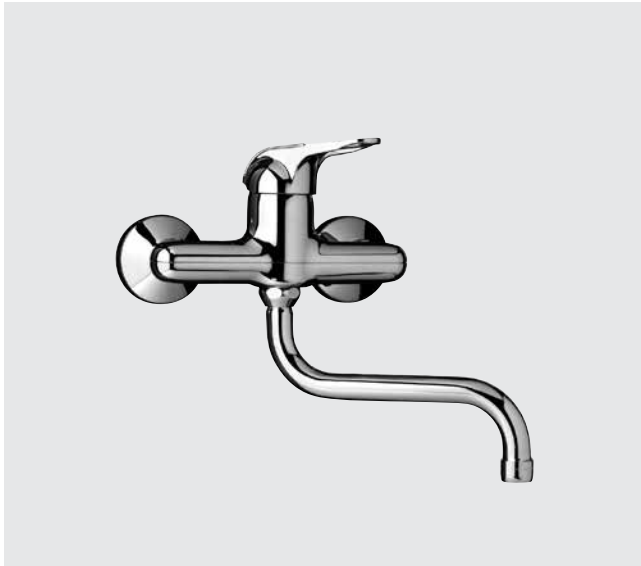

## 45CR501TC

Monocomando lavello a muro

Wall mounted single-lever kitchen mixer

Mitigeur évier mural

Mezclador fregadero exterior

Wand-Spültischmischer

RICAMBI / SPARE PARTS:

**53CC956GM** CARTUCCIA / CARTRIDGE

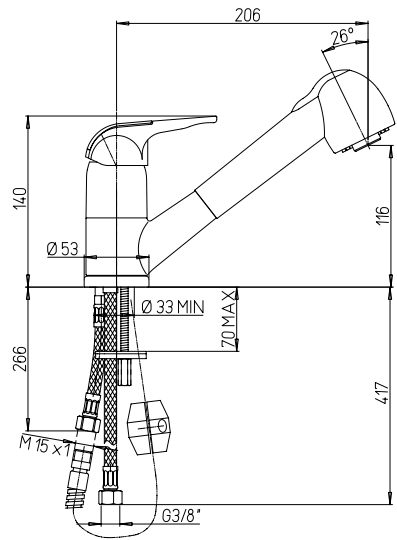

## 45CR568TC

**Miscelatore monoforo lavello con doccia estraibile**  
 Single-lever kitchen mixer with pull-out spray  
**Mitigeur monotrou évier avec douche escamotable**  
 Mezclador monomando fregadero con ducha extraíble  
 Spültischmischer mit herausziehbarer Handbrause

RICAMBI / SPARE PARTS:  
**53CC956GM** CARTUCCIA / CARTRIDGE

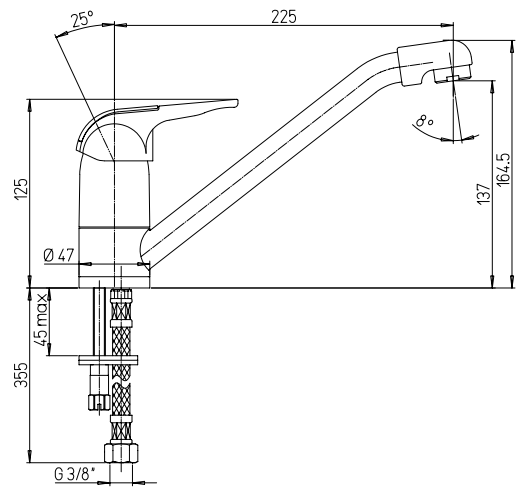

## 45CR573TC

**Monocomando monoforo lavello bocca coassiale**  
 Single-lever kitchen mixer with swivel spout  
**Mitigeur évier avec bec orientable**  
 Mezclador monomando fregadero, caño giratorio  
 Einhebelmischer mit schwenkbarem Auslauf

RICAMBI / SPARE PARTS:  
**53CC956GM** CARTUCCIA / CARTRIDGE

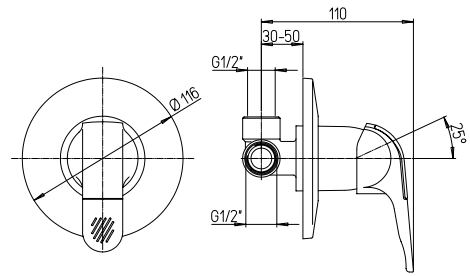
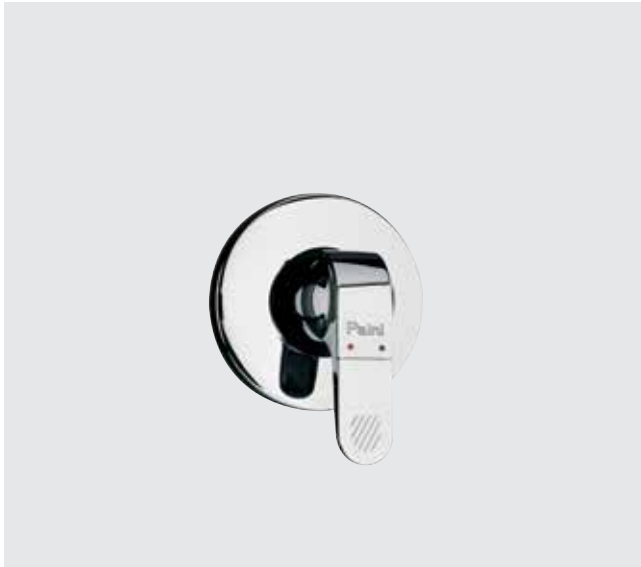

## 45CR690TC

**Miscelatore doccia incasso**  
 Built-in single-lever shower mixer  
**Mitigeur douche à encastrer**  
 Mezclador ducha empotrado  
 Einbau Brausebatterie

RICAMBI / SPARE PARTS:  
**53CC956GM** CARTUCCIA / CARTRIDGE

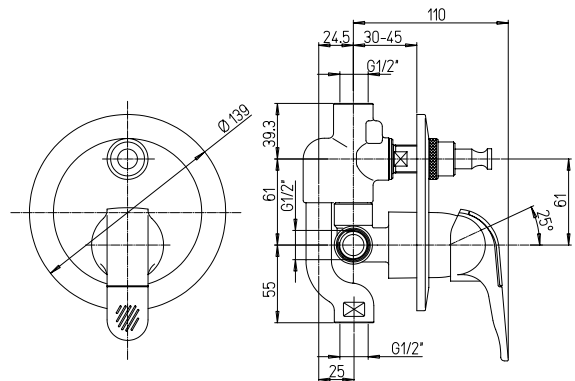

## 45CR691TC

**Miscelatore doccia incasso con deviatore**  
 Built-in single-lever bath-shower mixer with diverter  
**Mitigeur bain-douche à encastrer avec inverseur**  
 Mezclador monomando baño-doucha empotrado  
 Einbau Brausemischer mit Umschalter

RICAMBI / SPARE PARTS:  
**53CC956GM** CARTUCCIA / CARTRIDGE

# MR

# miura



**Bi**  **Water**  
system



Il nuovo sistema adottato per la serie Miura, fa sì che il flusso dell'acqua non venga mai a contatto con alcun tipo di metallo evitandone così la cessione. Questa nuova concezione di erogazione tutela la salute dell'utilizzatore finale.

Miura taps are conceived with a BioWater System which prevents water flow coming into contact with any metal parts, so avoiding contaminations. This new water system protects the consumer's health.

*OPAINI*

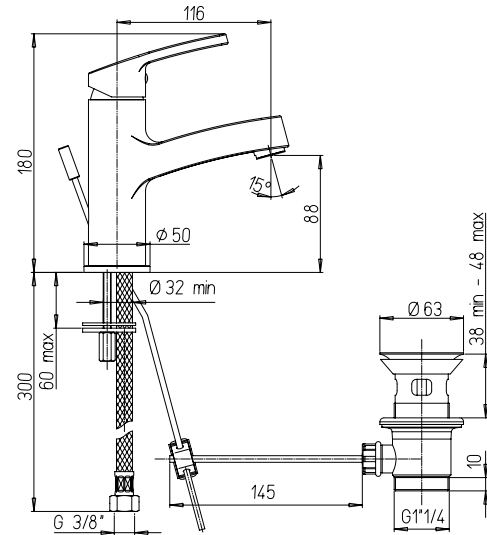

## MRCR211



Miscelatore monoforo lavabo con scarico automatico 1"1/4  
 Single-lever basin mixer with 1"1/4 pop-up waste  
 Mitigeur lavabo avec vidage automatique 1"1/4  
 Mezclador lavabo con desagüe automático 1"1/4  
 Waschtischmischer Ab- und Überlaufgarnitur 1"1/4

RICAMBI / SPARE PARTS:  
**53CC956G35EP** CARTUCCIA / CARTRIDGE

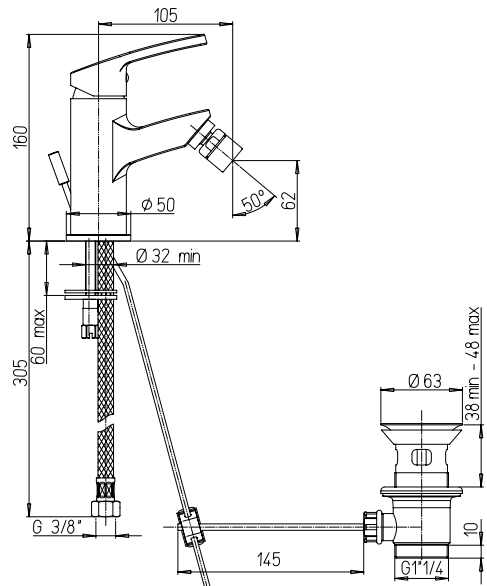

## MRCR306



Miscelatore monoforo bidet, scarico automatico 1"1/4  
 Single-lever bidet mixer with 1"1/4 pop-up waste  
 Mitigeur bidet avec vidage automatique 1"1/4  
 Mezclador monomando bidé con desagüe automático 1"1/4  
 Bidetmischer Ab- und Überlaufgarnitur 1"1/4

RICAMBI / SPARE PARTS:  
**53CC956G35EP** CARTUCCIA / CARTRIDGE

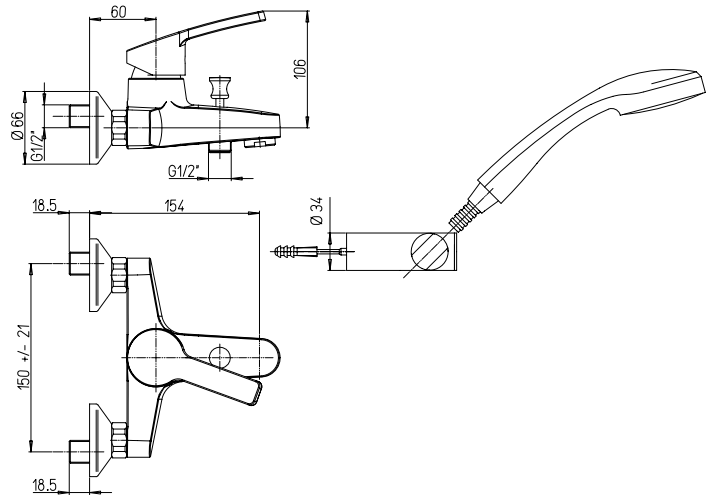

## MRCR105

**Miscelatore vasca esterno con doccia "Duplex"**

Single lever bath-shower mixer with adjustable shower kit

**Mitigeur bain-douche apparent avec garniture de douche orientable**

Mezclador baño-ducha con equipo ducha, soporte articulado

**Bademischer mit Brausegarnitur, Brausehalter verstellbar**

RICAMBI / SPARE PARTS:

**53CC956GM** CARTUCCIA / CARTRIDGE

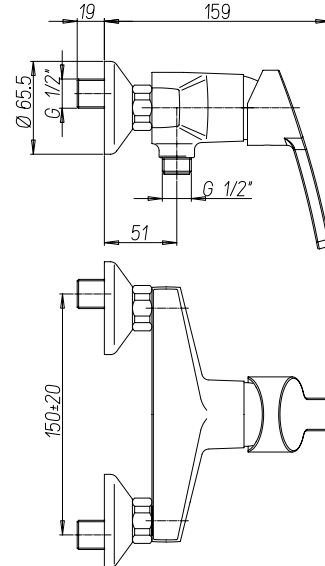

## MRCR511

**Miscelatore doccia esterno 1/2"**

1/2" single-lever shower mixer

**Mitigeur douche apparent nu 1/2"**

Mezclador monomando ducha 1/2" sin equipo ducha

**Brausemischer 1/2"**

RICAMBI / SPARE PARTS:

**53CC956GM** CARTUCCIA / CARTRIDGE



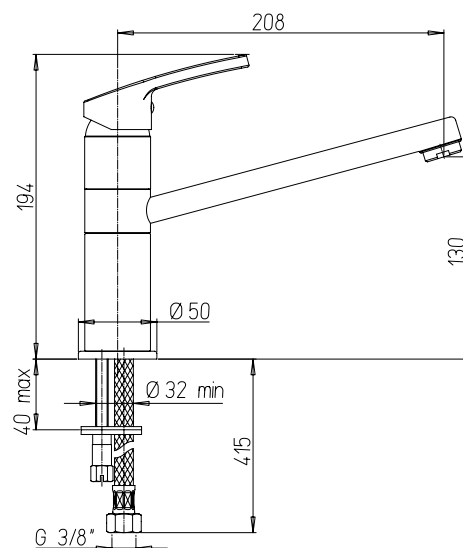

## MRCR573



**Monocomando monoforo livello bocca coassiale**

Single-lever kitchen mixer with swivel spout

**Mitigeur évier avec bec orientable**

Mezclador monomando fregadero, caño giratorio

Einhebelmischer mit schwenkbarem Auslauf

RICAMBI / SPARE PARTS:

**53CC956G35EP** CARTUCCIA / CARTRIDGE

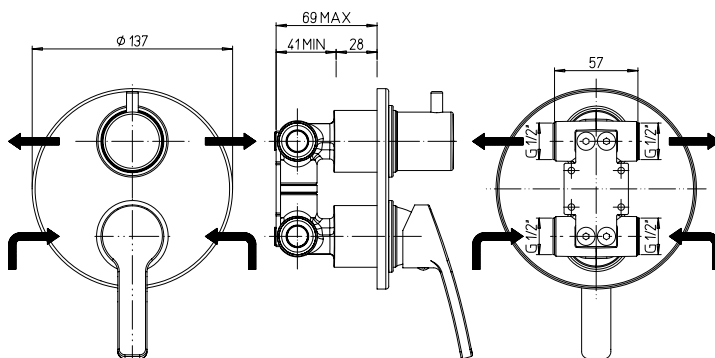
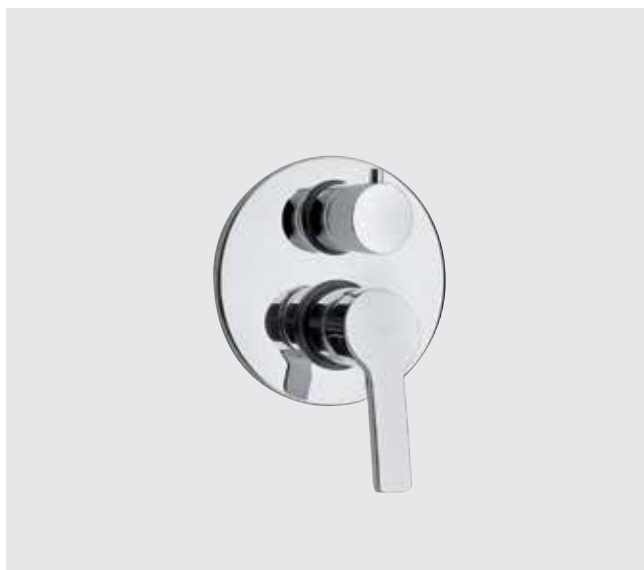

## MRCR6911

**Miscelatore doccia incasso con deviatore rotativo 2 uscite**

Built-in single-lever bath-shower mixer with 2-way rotary diverter valve

**Mitigeur bain-douche à encastrer avec inverseur rotatif 2 sorties**

Mezclador monomando baño-ducha empotrado con desviador giratorio 2 salidas

Einbau Brausemischer mit Drehumsteller, 2 Wege

RICAMBI / SPARE PARTS:

**53CC956GM** CARTUCCIA / CARTRIDGE

69

jolly



*ÓPaini*

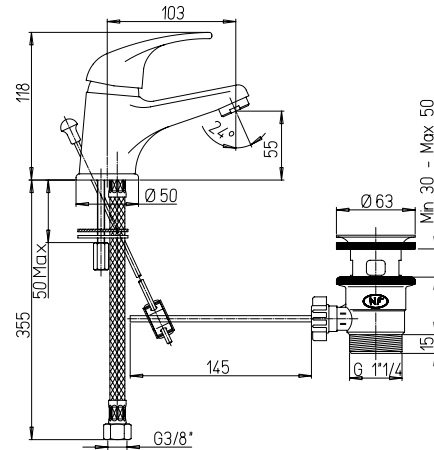

## 69CR211ZO

Miscelatore monoforo lavabo, scarico automatico 1"1/4  
 Single-lever basin mixer with 1"1/4 pop-up waste  
 Mitigeur lavabo avec vidage automatique 1"1/4  
 Mezclador lavabo con desagüe automático 1"1/4  
 Waschtischmischer Ab- und Überlaufgarnitur 1"1/4

RICAMBI / SPARE PARTS:  
**53CC956GMD** CARTUCCIA / CARTRIDGE

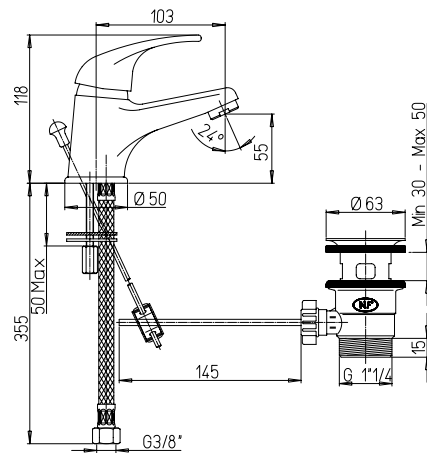

## 69CR200Z

Miscelatore monoforo lavabo **MONOACQUA**, scarico automatico 1"1/4  
 Basin tap with 1"1/4 waste  
 Robinet simple lavabo  
 Grifo lavabo  
 Standventil

RICAMBI / SPARE PARTS:  
**53CC956GMD** CARTUCCIA / CARTRIDGE

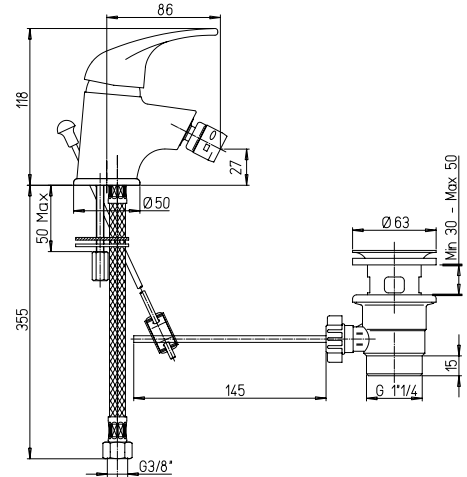
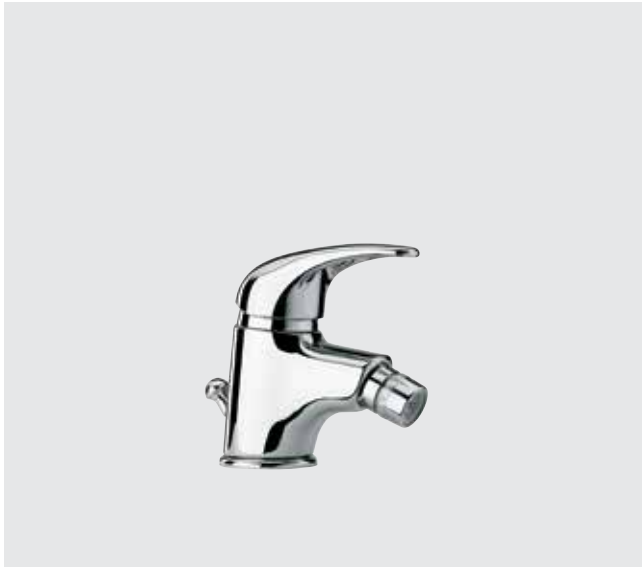

## 69CR306ZO

**Miscelatore monoforo bidet, scarico automatico 1"1/4**  
 Single-lever bidet mixer with 1"1/4 pop-up waste  
**Mitigeur bidet avec vidage automatique 1"1/4**  
 Mezclador monomando bidé con desagüe automático 1"1/4  
**Bidetmischer Ab- und Überlaufgarnitur 1"1/4**

RICAMBI / SPARE PARTS:  
**53CC956GMD** CARTUCCIA / CARTRIDGE

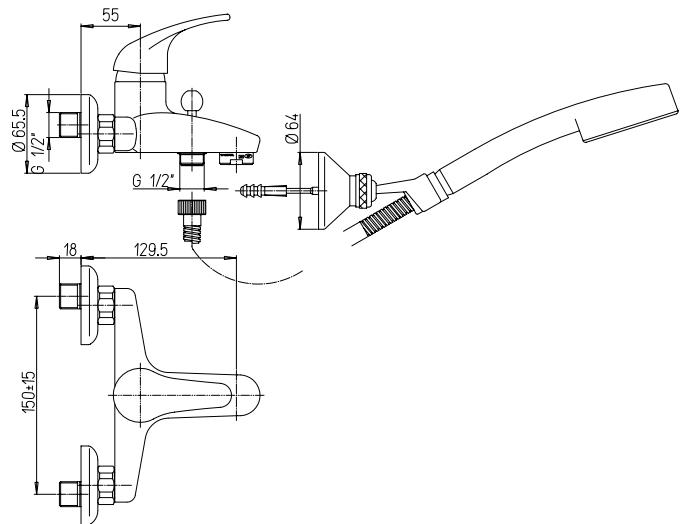

## 69CR105Z

**Miscelatore vasca esterno con doccia "Duplex"**  
 Single lever bath-shower mixer with adjustable shower kit  
**Mitigeur bain-douche apparent avec garniture de douche orientable**  
 Mezclador monomando baño-ducha mural con equipo ducha, soporte articulado  
**Bademischer mit Brausegarnitur, Brausehalter verstellbar**

RICAMBI / SPARE PARTS:  
**53CC956GMD** CARTUCCIA / CARTRIDGE

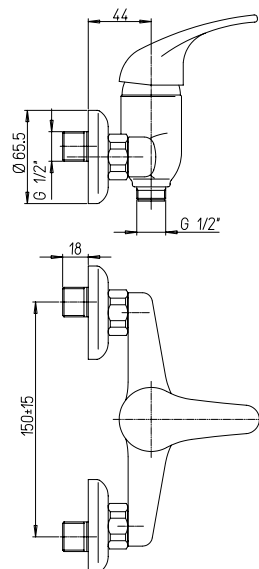
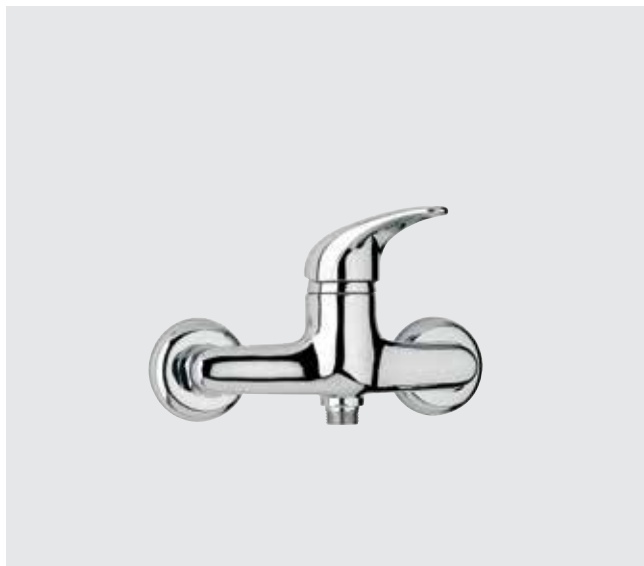

## 69CR511Z

**Miscelatore doccia esterno 1/2"**

1/2" single-lever shower mixer

**Mitigeur douche apparent nu 1/2"**

Mezclador monomando ducha 1/2" sin equipo ducha

**Brausemischer 1/2"**

RICAMBI / SPARE PARTS:

**53CC956GMD** CARTUCCIA / CARTRIDGE

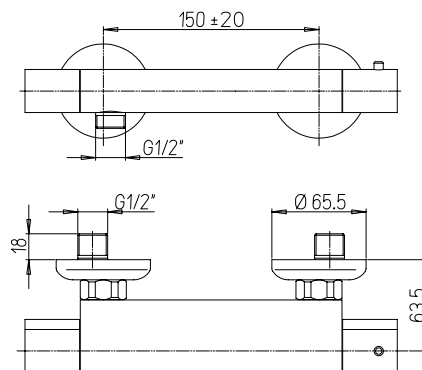

## 69CR511TH

**Gruppo doccia esterno termostatico**

Thermostatic shower mixer

**Mitigeur thermostatique douche**

Mezclador termostático ducha

**Thermostat-Brausemischer**

RICAMBI / SPARE PARTS:

**53CC180NF** VITONE / HEADWORK

**69CC959** CARTUCCIA TERMO / THERMO CARTRIDGE

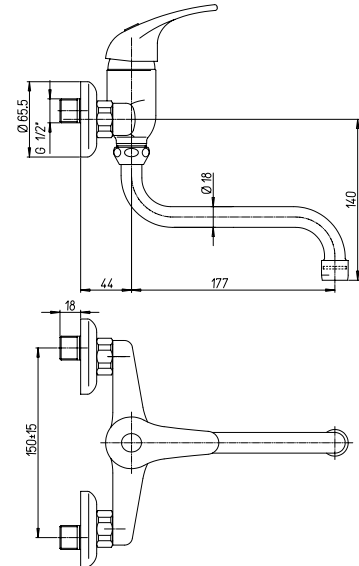

## 69CR501Z

Monocomando lavello a muro  
 Wall mounted single-lever kitchen mixer  
**Mittigeur évier mural**  
 Mezclador fregadero exterior  
 Wand-Spültischmischer

RICAMBI / SPARE PARTS:  
**53CC956GMD** CARTUCCIA / CARTRIDGE

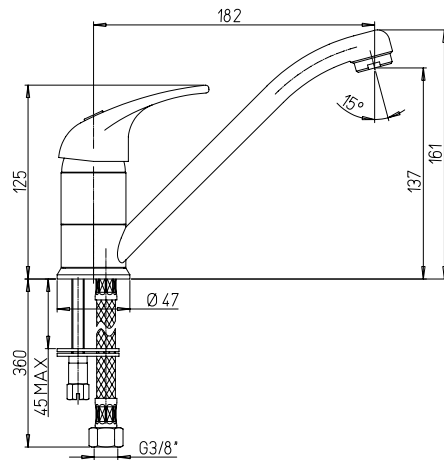

## 69CR573Z

Monocomando monoforo lavello bocca coassiale  
 Single-lever kitchen mixer with swivel spout  
**Mittigeur évier avec bec orientable**  
 Mezclador monomando fregadero, caño giratorio  
 Einhebelmischer mit schwenkbarem Auslauf

RICAMBI / SPARE PARTS:  
**53CC956GM** CARTUCCIA / CARTRIDGE

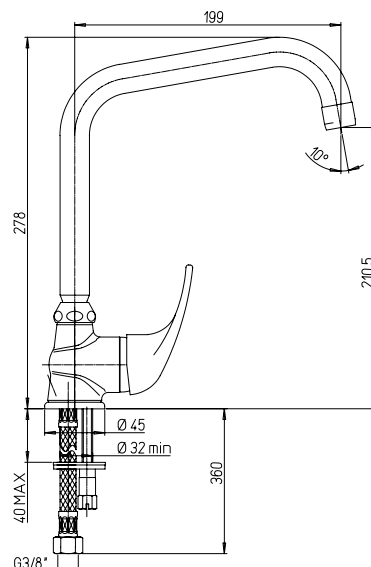

## 69CR594Z

Monocomando monoforo lavello con bocca tubo 90°

Single-lever kitchen mixer with 90° tube spout

Mitigeur évier bec tube 90°

Mezclador fregadero con caño tubular 90°

Einloch-Spültischmischer mit 90° Rohrauslauf

RICAMBI / SPARE PARTS:

**53CC956GM** CARTUCCIA / CARTRIDGE

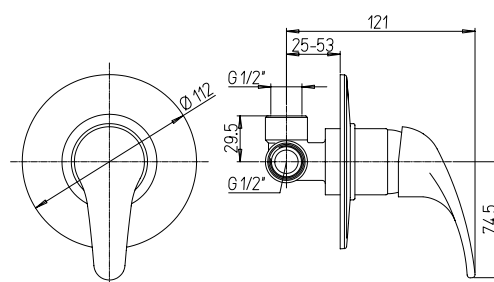

## 69CR690Z

Miscelatore doccia incasso

Built-in single-lever shower mixer

Mitigeur douche à encastrer

Mezclador ducha empotrado

Einbau Brausebatterie

RICAMBI / SPARE PARTS:

**53CC956GM** CARTUCCIA / CARTRIDGE

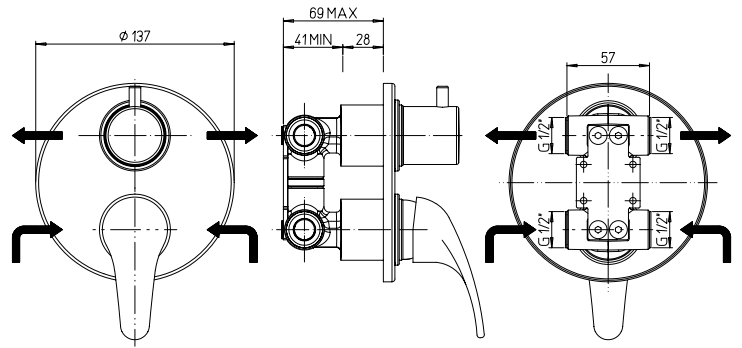

## 69CR6911Z

**Miscelatore doccia incasso con deviatore rotativo 2 uscite**

Built-in single-lever bath-shower mixer with 2-way rotary diverter valve

**Mitigeur bain-douche à encastrer avec inverseur rotatif 2 sorties**

Mezclador monomando baño-ducha empotrado con desviador giratorio 2 salidas

Einbau Brausemischer mit Drehumsteller, 2 Wege

RICAMBI / SPARE PARTS:

**53CC956GM** CARTUCCIA / CARTRIDGE





17

liberty



*ÓPaini*

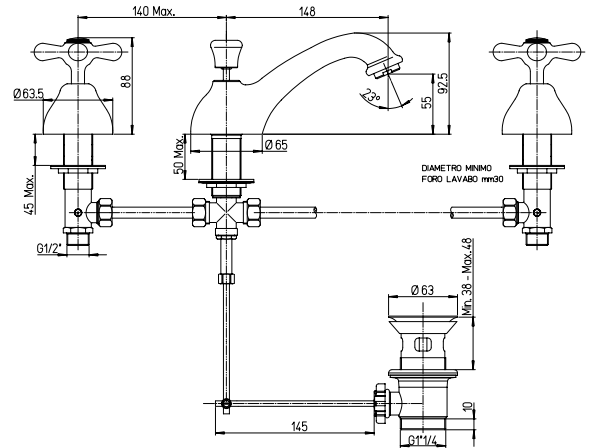

## 17CR211

Batteria lavabo 3 fori, scarico automatico 1"1/4  
 3-hole basin mixer, 1"1/4 pop-up waste  
 Mélangeur lavabo avec vidage automatique 1"1/4  
 Batería lavabo con desagüe automático 1"1/4  
 Waschtischbatterie, Ab- und Überlaufgarnitur 1"1/4

RICAMBI / SPARE PARTS:  
**49CR581AD** VITONE / HEADWORK

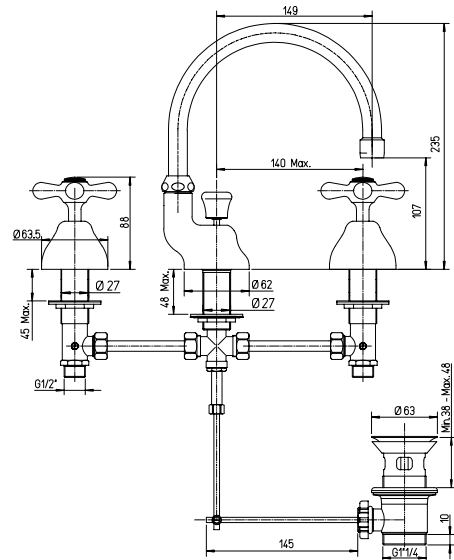

## 17CR214

Batteria lavabo 3 fori con bocca orientabile, scarico automatico 1"1/4  
 3-hole basin mixer with swivel spout, 1"1/4 pop-up waste  
 Mélangeur lavabo bec orientable avec vidage automatique 1"1/4  
 Batería lavabo caño giratorio con desagüe automático 1"1/4  
 Waschtischbatterie mit schwenkbarem Auslauf, Ab- und Überlaufgarnitur 1"1/4

RICAMBI / SPARE PARTS:  
**49CR581AD** VITONE / HEADWORK

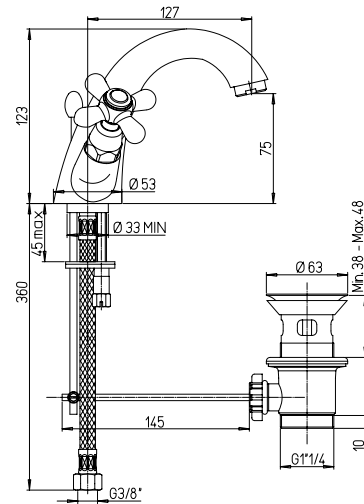

## 17CR243

**Monoblocco lavabo, scarico automatico 1"1/4**

Basin monobloc, 1"1/4 pop-up waste

**Mélangeur lavabo, vidage automatique 1"1/4**

Mezclador lavabo, desagüe automático 1"1/4

Waschtischbatterie, Ab- und Überlaufgarnitur 1"1/4

RICAMBI / SPARE PARTS:

**49CR581AD** VITONE / HEADWORK

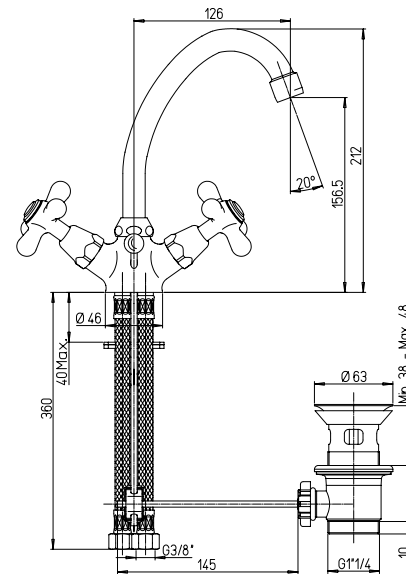

## 17CR250

**Monoforo lavabo con bocca tubo orientabile, scarico automatico 1"1/4**

Basin mixer with swivel spout, 1"1/4 pop-up waste

**Mélangeur lavabo avec bec haut orientable, vidage automatique 1"1/4**

Mezclador lavabo con caño alto giratorio, desagüe automático 1"1/4

Waschtischbatterie mit schwenkbarem Auslauf, Ab- und Überlaufgarnitur 1"1/4

RICAMBI / SPARE PARTS:

**49CR581AD** VITONE / HEADWORK

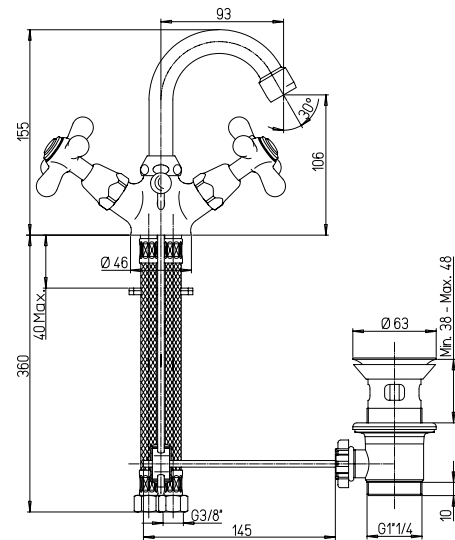

## 17CR251

**Monoforo bidet con bocca tubo orientabile, scarico automatico 1"1/4**  
 Bidet monobloc mixer with swivel spout, 1"1/4 pop-up waste  
**Mélangeur bidet avec bec orientable, vidage automatique 1"1/4**  
 Mezclador bidé con caño giratorio, desagüe automático 1"1/4  
 Bidetmischer mit schwenkbarem Auslauf, Ab- und Überlaufgarnitur 1"1/4

RICAMBI / SPARE PARTS:  
**49CR581AD** VITONE / HEADWORK

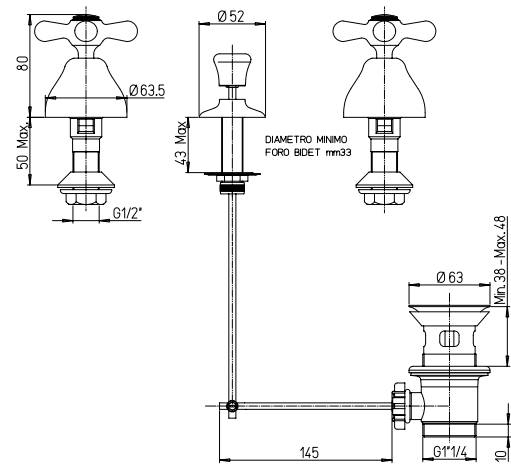

## 17CR306

**Batteria bidet, scarico automatico 1"1/4**  
 3-hole bidet mixer, 1"1/4 pop-up waste  
**Mélangeur bidet avec vidage automatique 1"1/4**  
 Batería bidé con desagüe automático 1"1/4  
 Bidetbatterie, Ab- und Überlaufgarnitur 1"1/4

RICAMBI / SPARE PARTS:  
**49CR581AD** VITONE / HEADWORK

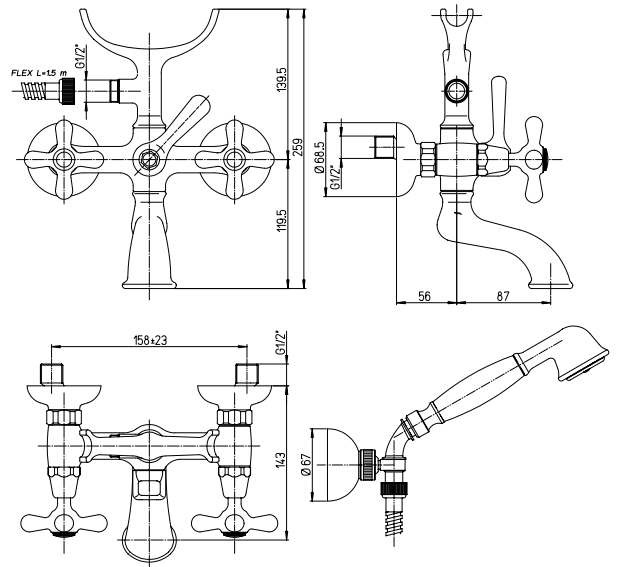

## 17CR105

**Gruppo vasca esterno con doccia "Duplex"**

Bath-shower mixer with adjustable shower kit

**Mélangeur bain-douche apparent avec garniture de douche orientable**

Mezclador baño-ducha con equipo ducha, soporte articulado

Wannenbatterie mit Brausegarnitur, Brausehalter verstellbar

RICAMBI / SPARE PARTS:

**49CR581AD** VITONE / HEADWORK

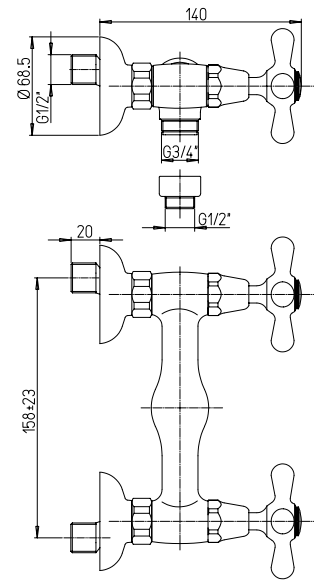

## 17CR511

**Gruppo doccia esterno 1/2"**

1/2" shower mixer

**Mélangeur douche apparent nu 1/2"**

Mezclador ducha 1/2" sin equipo ducha

Brausemischer 1/2"

RICAMBI / SPARE PARTS:

**49CR581AD** VITONE / HEADWORK

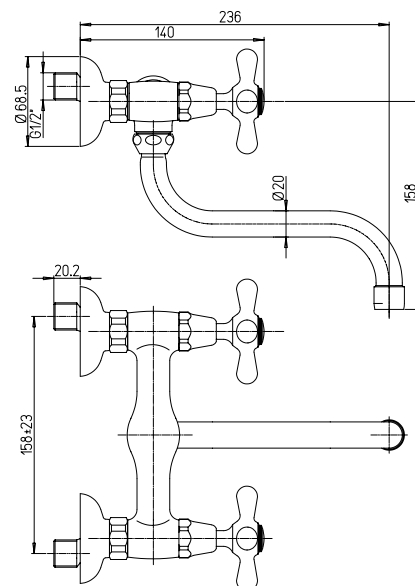

## 17CR501

**Gruppo lavello a muro**  
 Wall mounted kitchen mixer  
**Mélangeur évier mural**  
 Mezclador fregadero exterior  
**Wand-Spültischbatterie**

RICAMBI / SPARE PARTS:  
**49CR581AD** VITONE / HEADWORK

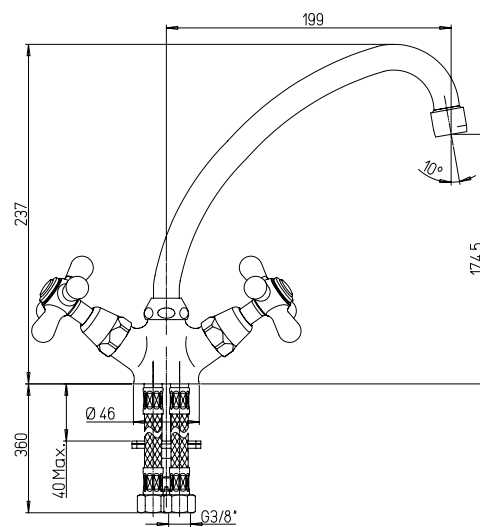

## 17CR570

**Monoforo lavello con bocca tubo**  
 Kitchen monobloc with tube spout  
**Mélangeur évier bec tube**  
 Mezclador fregadero con caño tubular  
**Einloch-Spültischbatterie, Rohrauslauf**

RICAMBI / SPARE PARTS:  
**49CR581AD** VITONE / HEADWORK

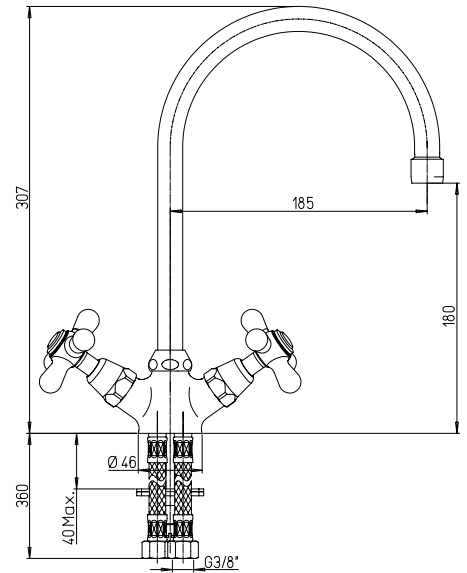

## 17CR572

**Monoforo lavello con bocca tubo**

Kitchen monobloc with tube spout

**Mélangeur évier bec tube**

Mezclador fregadero con caño tubular

Einloch-Spültischbatterie, Rohrauslauf

RICAMBI / SPARE PARTS:

**49CR581AD** VITONE / HEADWORK





87

ornellaia



*OPaini*

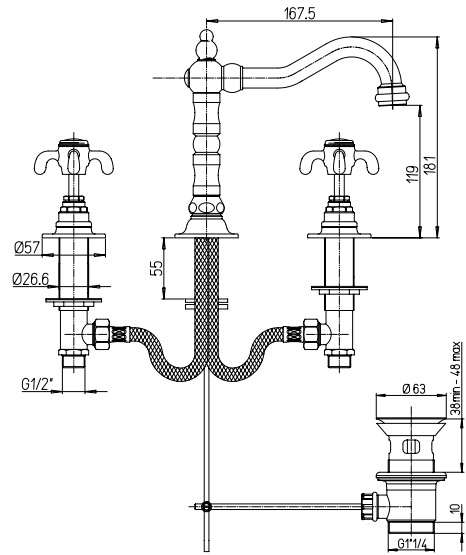

## 87CR214B

Batteria lavabo 3 fori con bocca "Barocco" orientabile, scarico automatico 1"1/4  
 3-hole basin mixer with swivel spout, 1"1/4 pop-up waste  
 Mélangeur lavabo bec orientable avec vidage automatique 1"1/4  
 Batería lavabo caño giratorio con desagüe automático 1"1/4  
 Waschtischbatterie mit schwenkbarem Auslauf, Ab- und Überlaufgarnitur 1"1/4

RICAMBI / SPARE PARTS:  
**49CR581AD** VITONE / HEADWORK

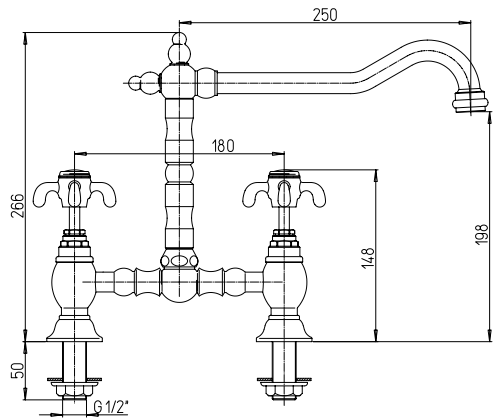

## 87CR215B

Gruppo lavabo a ponte con bocca "Barocco"  
 Bridge basin mixer with "Baroque" spout  
 Mélangeur lavabo, bec « Barocco »  
 Batería lavabo, caño „Barocco“  
 Waschtischbatterie mit „Barocco“ Auslauf

RICAMBI / SPARE PARTS:  
**49CR581AD** VITONE / HEADWORK

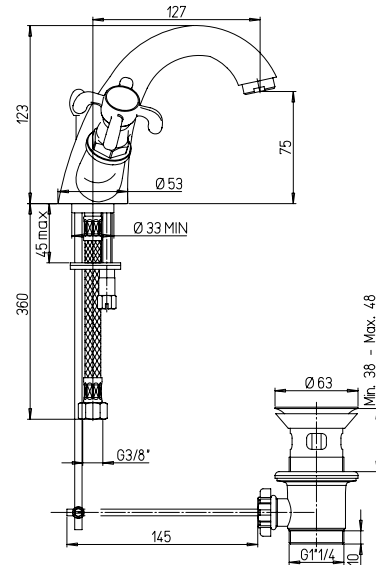

## 87CR243

**Monoblocco lavabo, scarico automatico 1"1/4**

Basin monobloc, 1"1/4 pop-up waste

**Mélangeur lavabo, vidage automatique 1"1/4**

Mezclador lavabo, desagüe automático 1"1/4

**Waschtischbatterie, Ab- und Überlaufgarnitur 1"1/4**

RICAMBI / SPARE PARTS:

**49CR581AD** VITONE / HEADWORK

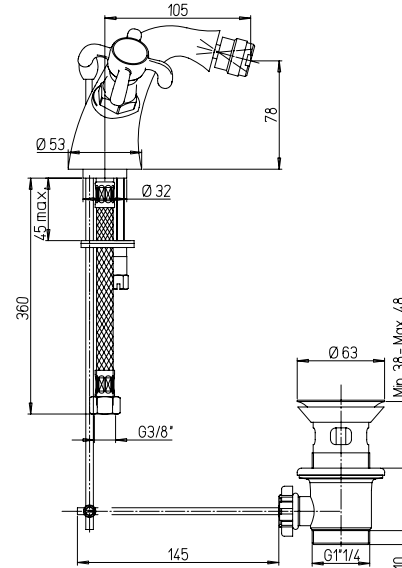

## 87CR327

**Monoblocco bidet, scarico automatico 1"1/4**

Bidet monobloc, 1"1/4 pop-up waste

**Mélangeur bidet, vidage automatique 1"1/4**

Mezclador bidé, desagüe automático 1"1/4

**Bidetbatterie, Ab- und Überlaufgarnitur 1"1/4**

RICAMBI / SPARE PARTS:

**49CR581AD** VITONE / HEADWORK

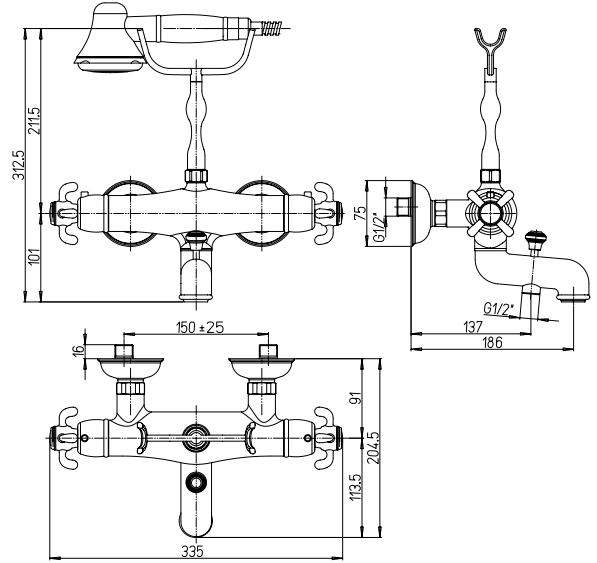

## 87CR100TH

**Monoblocco lavabo, scarico automatico 1"1/4**

Basin monobloc, 1"1/4 pop-up waste

**Mélangeur lavabo, vidage automatique 1"1/4**

Mezclador lavabo, desagüe automático 1"1/4

**Waschtischbatterie, Ab- und Überlaufgarnitur 1"1/4**

RICAMBI / SPARE PARTS:

**53CR581ZD** VITONE / HEADWORK

**2TCC959** CARTUCCIA TERMO / THERMO CARTRIDGE

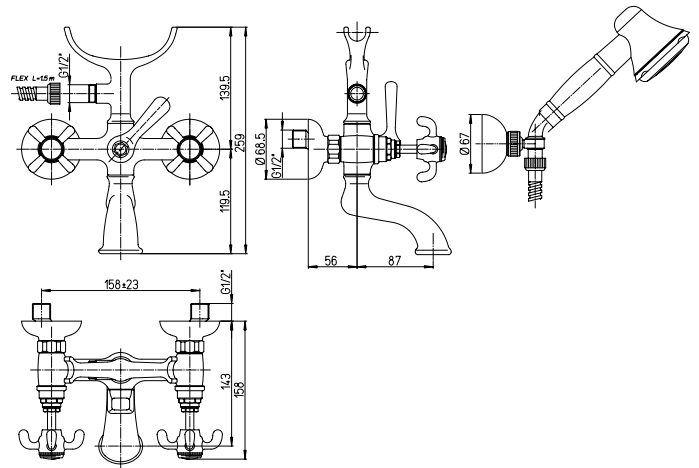

## 87CR105

**Gruppo vasca esterno con doccia "Duplex"**

Bath-shower mixer with adjustable shower kit

**Mélangeur bain-douche apparent avec garniture de douche orientable**

Mezclador baño-ducha con equipo ducha, soporte articulado

**Wannenbatterie mit Brausegarnitur, Brausehalter verstellbar**

RICAMBI / SPARE PARTS:

**49CR581AD** VITONE / HEADWORK

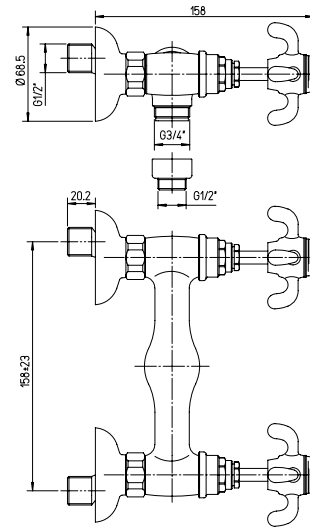

## 87CR511

**Gruppo doccia esterno 1/2"**

1/2" shower mixer

**Mélangeur douche apparent nu 1/2"**

Mezclador ducha 1/2" sin equipo ducha

**Brausemischer 1/2"**

RICAMBI / SPARE PARTS:

**49CR581AD** VITONE / HEADWORK

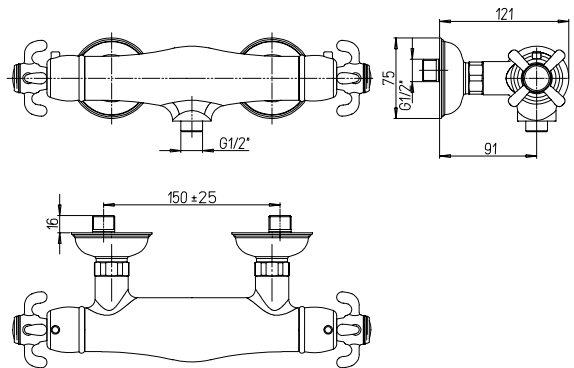

## 87CR511TH

**Miscelatore termostatico esterno doccia**

Thermostatic shower mixer

**Mitigeur thermostatique douche**

Mezclador termostático ducha

**Thermostat-Brausemischer**

RICAMBI / SPARE PARTS:

**53CR581ZD** VITONE / HEADWORK

**2TCC959** CARTUCCIA TERMO / THERMO CARTRIDGE

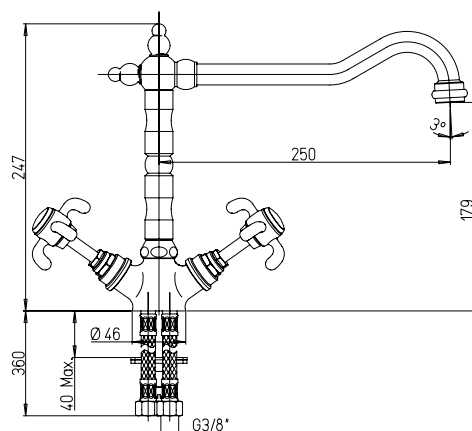

## 87CR570B

**Monoforo lavello con bocca "Barocco" orientabile**  
 Kitchen monobloc with swivel spout  
**Mélangeur évier avec bec orientable**  
 Mezclador fregadero con caño giratorio  
 Einloch-Spültischbatterie mit schwenkbarem Auslauf

RICAMBI / SPARE PARTS:  
**49CR581AD** VITONE / HEADWORK

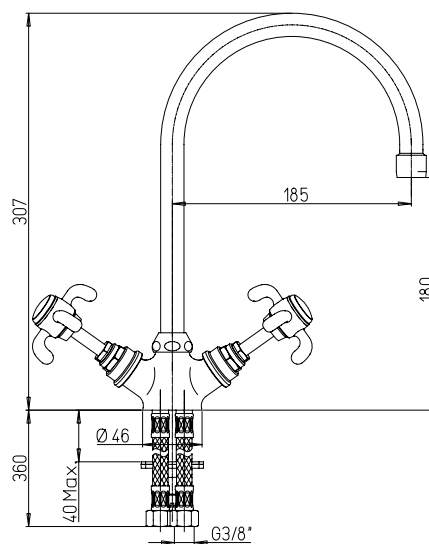

## 87CR572

**Monoforo lavello con bocca tubo orientabile**  
 Kitchen monobloc with swivel tube spout  
**Mélangeur évier bec tube orientable**  
 Mezclador fregadero con caño tubular giratorio  
 Einloch-Spültischbatterie mit schwenkbarem Rohrauslauf

RICAMBI / SPARE PARTS:  
**49CR581AD** VITONE / HEADWORK

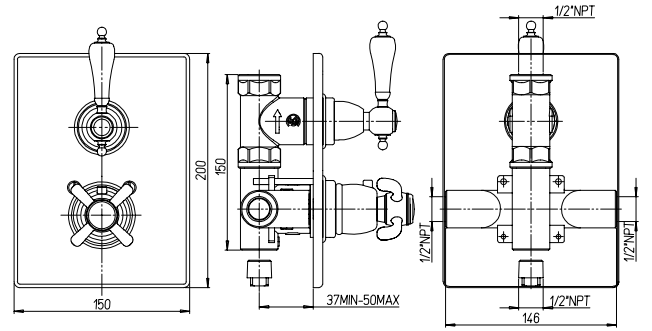

## 87CR690TH

**Gruppo doccia incasso termostatico con rubinetto di arresto**

Built-in thermostatic shower mixer with stop valve

**Mitigeur douche thermostatique à encastrer avec robinet d'arrêt**

Mezclador termostático ducha empotrado con llave de paso

Einbau Thermostat-Brausebatterie mit Absperrventil

RICAMBI / SPARE PARTS:

**53CC5813/4S25** VITONE / HEADWORK

**2TCC959** CARTUCCIA TERMO / THERMO CARTRIDGE

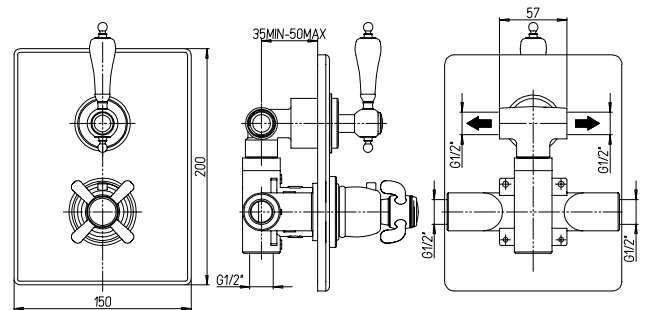

## 87CR691TH

**Gruppo doccia incasso termostatico con rubinetto di arresto e deviatore 2 uscite**

Built-in thermostatic shower mixer with stop valve and 2-way diverter

**Mitigeur douche thermostatique à encastrer avec robinet d'arrêt et inverseur 2 voies**

Mezclador termostático ducha empotrado con llave de paso e inversor 2 vías

Einbau Thermostat-Brausemischer mit Absperrventil und 2-Wege Umsteller

RICAMBI / SPARE PARTS:

**53CR956D35/425** CARTUCCIA / CARTRIDGE

**2TCC959** CARTUCCIA TERMO / THERMO CARTRIDGE



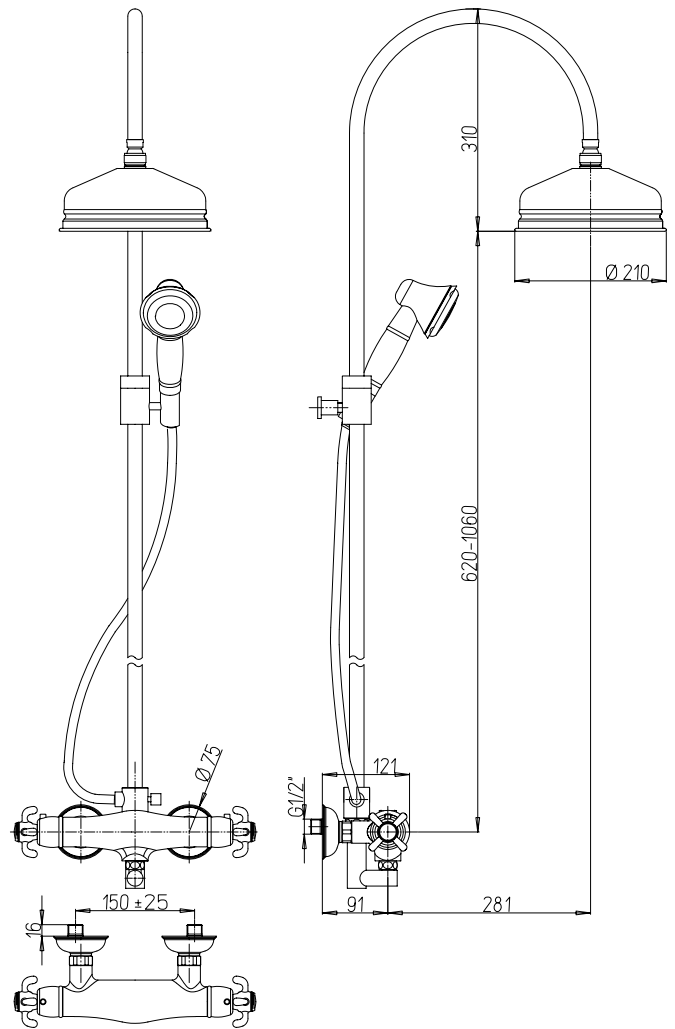

## 87CR689TH

Gruppo doccia termostatico completo

Complete thermostatic shower mixer

Mitigeur thermostatique douche complet

Mezclador termostático ducha

Thermostat-Brausemischer komplett

RICAMBI / SPARE PARTS:

**53CR581ZD** VITONE / HEADWORK

**2TCC959** CARTUCCIA TERMO / THERMO CARTRIDGE

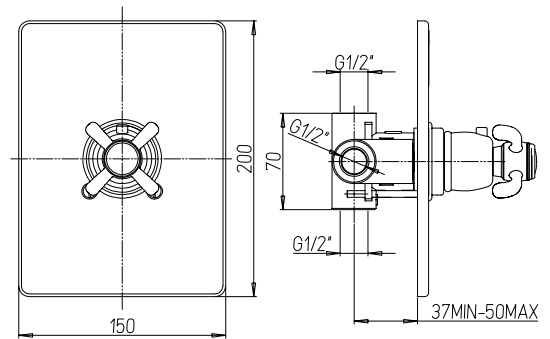

## 87CR710TH

**Termostatico incasso singolo**  
 Built-in thermostatic mixer  
**Mitigeur thermostatique à encastrer**  
 Mezclador termostático empotrado  
**Thermostat-Zentralbatterie**

RICAMBI / SPARE PARTS:  
**2TCC959** CARTUCCIA TERMO / THERMO CARTRIDGE

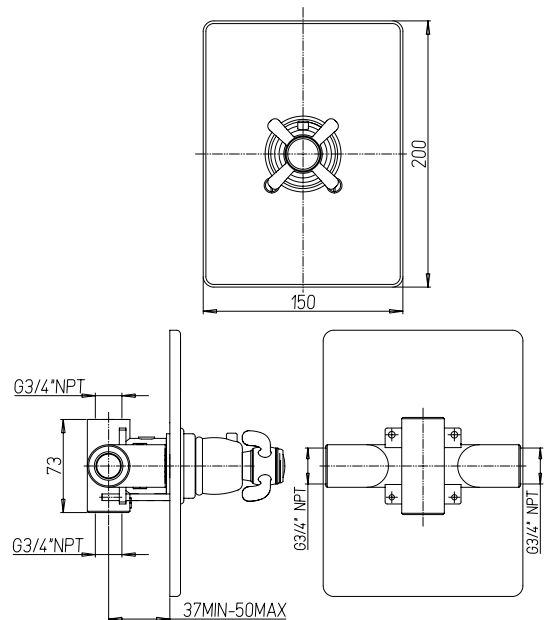

## 87CR711TH

**Miscelatore termostatico incasso 3/4" a 2 uscite parallele senza rubinetto di arresto**  
 3/4" built-in thermostatic mixer 2 parallel exits. without stop valve  
**Mitigeur douche thermostatique à encastrer 3/4", 2 sorties paralleles sans robinet d'arrêt**  
 Mezclador termostático ducha empotrar 3/4" 2 salidas paralelas con llave de paso  
**3/4" Einbau Thermostat-Brausebatterie 2 parallele Ausgänge mit Absperrventil**

RICAMBI / SPARE PARTS:  
**2TCC959** CARTUCCIA TERMO / THERMO CARTRIDGE



37

arno



*OPaini*

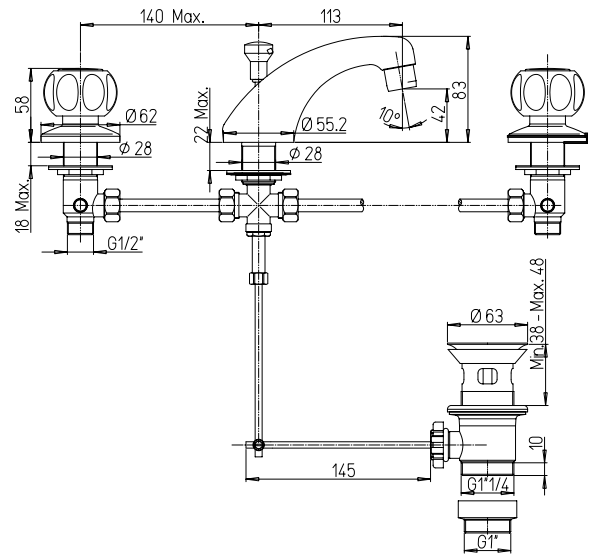

## 37CR211

Batteria lavabo 3 fori, scarico 1"1/4

3-hole basin mixer, 1"1/4 pop-up waste

Mélangeur lavabo avec vidage automatique 1"1/4

Batería lavabo con desagüe automático 1"1/4

Waschtischbatterie, Ab- und Überlaufgarnitur 1"1/4

RICAMBI / SPARE PARTS:

53CC180NFC VITONE / HEADWORK

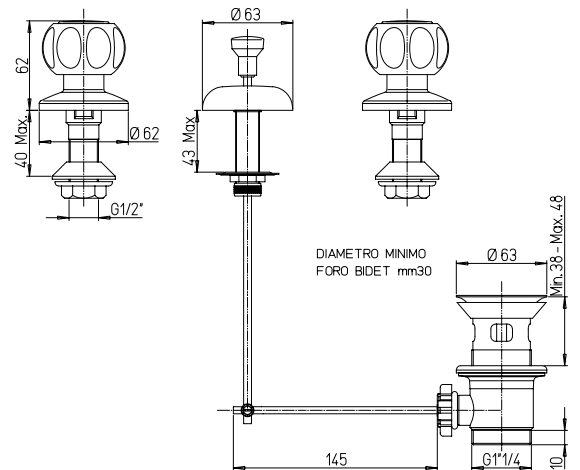

## 37CR306

Batteria bidet, scarico automatico 1"1/4

3-hole bidet mixer, 1"1/4 pop-up waste

Mélangeur bidet avec vidage automatique 1"1/4

Batería bidé con desagüe automático 1"1/4

Bidetbatterie, Ab- und Überlaufgarnitur 1"1/4

RICAMBI / SPARE PARTS:

53CC180NFC VITONE / HEADWORK

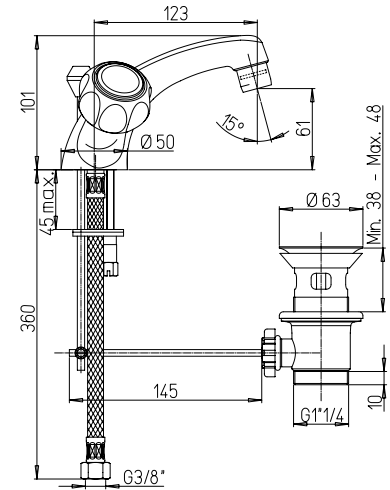

## 37CR241

**Monoblocco lavabo, scarico 1"1/4**

Basin monobloc, 1"1/4 pop-up waste

**Lavabo monotrou, vidage automatique 1"1/4**

Mezclador lavabo, desagüe 1"1/4

**Waschtischbatterie, Ab- und Überlaufgarnitur 1"1/4**

RICAMBI / SPARE PARTS:

**53CC180NFC VITONE / HEADWORK**

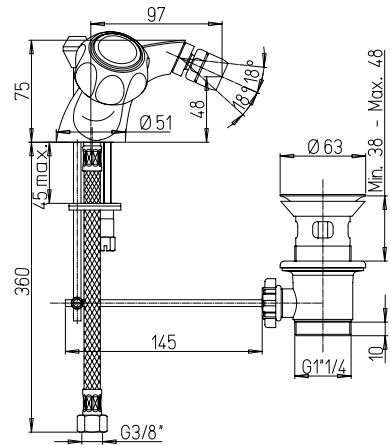

## 37CR326

**Monoblocco bidet, scarico 1"1/4**

Bidet monobloc, 1"1/4 pop-up waste

**Mélangeur monotrou bidet avec vidage automatique 1"1/4**

Mezclador bidé con desagüe automático 1"1/4

**Einloch-Bidetbatterie, Ab- und Überlaufgarnitur 1"1/4**

RICAMBI / SPARE PARTS:

**53CC180NFC VITONE / HEADWORK**





## 37CR501

**Gruppo lavello a muro**  
 Wall mounted kitchen mixer  
**Mélangeur évier mural**  
 Mezclador fregadero exterior  
 Wand-Spültischbatterie

RICAMBI / SPARE PARTS:  
**53CC180NFC** VITONE / HEADWORK

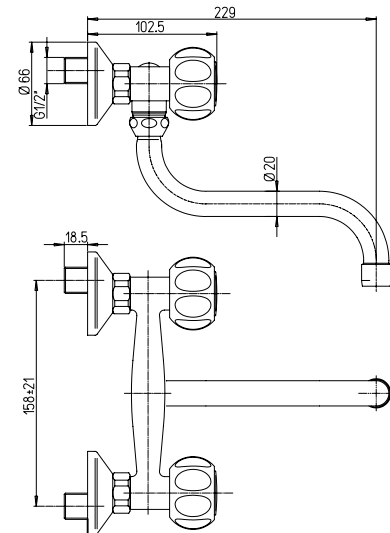

## 37CR570

**Monoforo lavello con bocca tubo**  
 Kitchen monobloc with tube spout  
**Mélangeur évier bec tube**  
 Mezclador fregadero con caño tubular  
 Einloch-Spültischbatterie, Rohrauslauf

RICAMBI / SPARE PARTS:  
**53CC180NFC** VITONE / HEADWORK

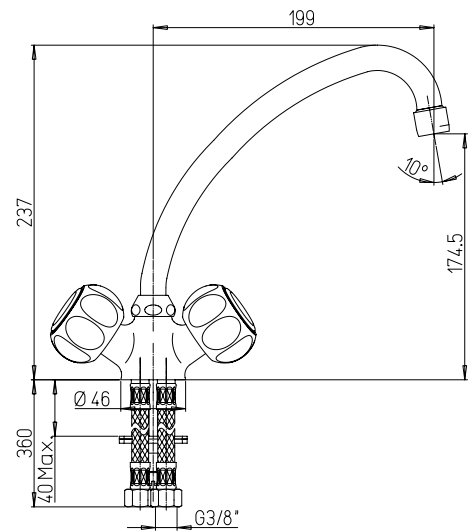



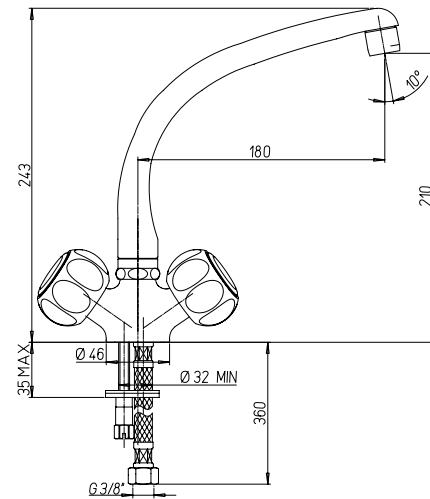

## 37CR571

**Monoforo lavello con bocca fusa orientabile**

Kitchen monobloc with swivel cast spout

**Mélangeur évier bec fondu orientable**

Mezclador fregadero con caño fundido giratorio

**Einloch-Spültischbatterie mit schwenkbarem Gussauslauf**

RICAMBI / SPARE PARTS:

**53CC180NFC** VITONE / HEADWORK

2T



*OPaini*

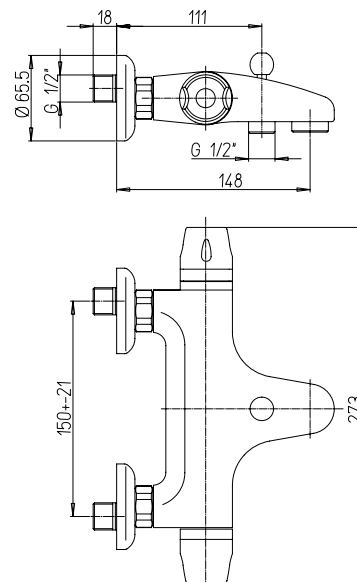

## 2TCR111TH

Gruppo vasca esterno termostatico senza "Duplex"

Thermostatic bath mixer

Mélangeur thermostatique bain-douche mural nu

Mezclador termostático para bañera

Thermostat-Wannenbatterie

RICAMBI / SPARE PARTS:

53CR581ADA VITONE / HEADWORK

2TCC959 CARTUCCIA TERMO / THERMO CARTRIDGE

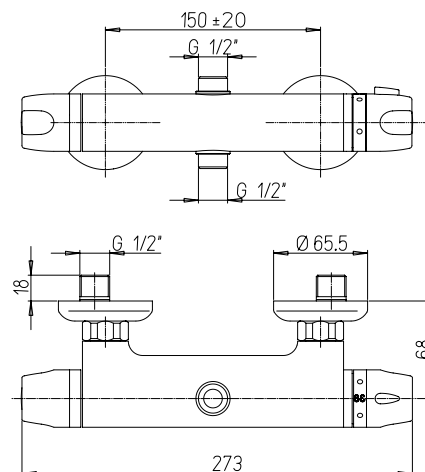

## 2TCR504TH

Gruppo termostatico doccia con deviatore 2 uscite

Thermostatic shower mixer with 2 ways diverter

Mitigeur thermostatique douche avec inverseur 2 voies

Mezclador termostático ducha con inversor 2 vías

Thermostat-Brausebatterie mit 2 Wege Umstellung

RICAMBI / SPARE PARTS:

53CC956DEV35 CARTUCCIA / CARTRIDGE

2TCC959 CARTUCCIA TERMO / THERMO CARTRIDGE

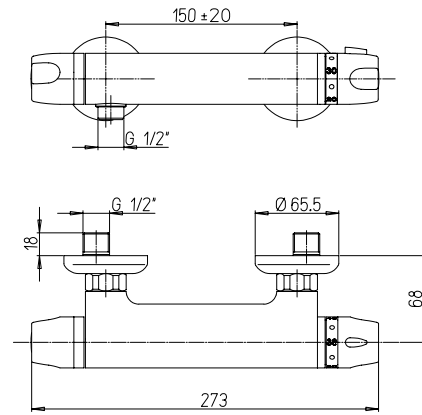

## 2TCR511TH

**Gruppo doccia esterno termostatico**  
 Thermostatic shower mixer  
**Mitigeur thermostatique douche**  
 Mezclador termostático ducha  
 Thermostat-Brausemischer

RICAMBI / SPARE PARTS:  
**53CR581ADA** VITONE / HEADWORK  
**2TCC959** CARTUCCIA TERMO / THERMO CARTRIDGE

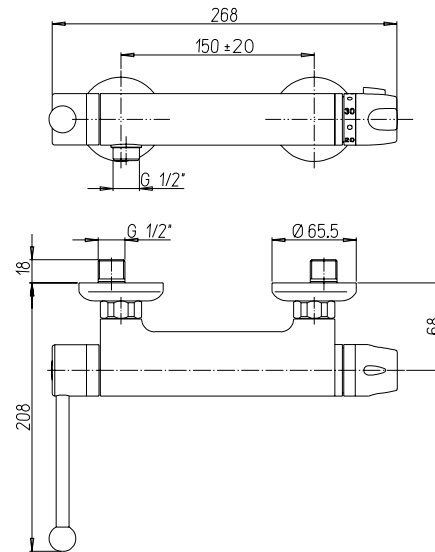

## 2TCR511THL

**Gruppo doccia esterno termostatico con leva lunga**  
 Thermostatic shower mixer with long lever  
**Mitigeur thermostatique douche, manette longue**  
 Mezclador termostático ducha palanca larga  
 Thermostat-Brausemischer mit langem Hebel

RICAMBI / SPARE PARTS:  
**53CR581ADA** VITONE / HEADWORK  
**2TCC959** CARTUCCIA TERMO / THERMO CARTRIDGE

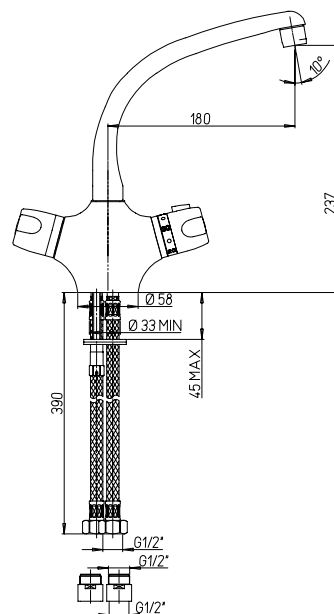

## 2TCR571TH

**Monoforo lavello termostatico con bocca fusa orientabile**

Thermostatic kitchen mixer with swivel cast spout

**Mitigeur thermostatique évier bec fondu orientable**

Mezclador fregadero termostático con caño fundido giratorio

**Einloch-Thermostat-Spültischmischer mit schwenkbarem Gussauslauf**

RICAMBI / SPARE PARTS:

**53CR581ADA** VITONE / HEADWORK

**2TCC959** CARTUCCIA TERMO / THERMO CARTRIDGE

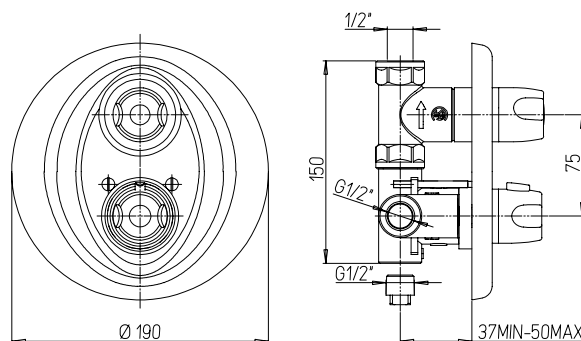

## 2TCR690TH

**Gruppo doccia incasso termostatico con rubinetto di arresto**

Built-in thermostatic shower mixer with stop valve

**Mitigeur douche thermostatique à encastrer avec robinet d'arrêt**

Mezclador termostático ducha empotrado con llave de paso

**Einbau Thermostat-Brausebatterie mit Absperrventil**

RICAMBI / SPARE PARTS:

**53CC5813/4S25** VITONE / HEADWORK

**2TCC959** CARTUCCIA TERMO / THERMO CARTRIDGE

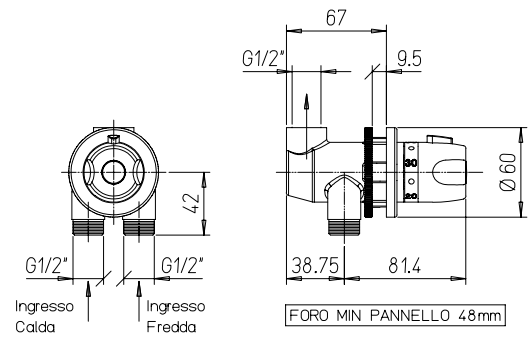

## 2TCR700TH

Miscelatore termostatico incasso doccia per pareti attrezzate o bordo vasca

Built-in thermostatic shower mixer

Mitigeur douche thermostatique à encastrer, sur gorge ou mural

Mezclador termostático ducha empotrar mural o inst.encimera

Einbau Thermostat-Brausebatterie

RICAMBI / SPARE PARTS:

**2TCC959** CARTUCCIA TERMO / THERMO CARTRIDGE



# condizioni generali di vendita

## **PREZZI**

I prezzi dei ns. listini sono soggetti a variazioni e non sono impegnativi, senza la ns. conferma. Essi s'intendono per merce resa franco nostro stabilimento, imballo escluso.

## **ORDINI**

Gli ordini ricevuti tramite la corrispondenza, fax o rappresentanti si considerano impegnativi solo dopo la nostra conferma debitamente sottoscritta. Con il conferimento dell'ordine il cliente accetta automaticamente tutte le condizioni di vendita di seguito indicate.

## **CONSEGNA**

I termini di consegna sono approssimativi e non vincolanti e non danno diritto al committente di annullare l'ordine o di reclamare danni di qualsivoglia natura, per ritardi derivanti da accidenti di fabbricazione, mancanza di materie prime, scioperi, interruzioni, ritardi nei trasporti o altre cause di forza maggiore. La merce viaggia a rischio e pericolo del committente, anche quando non è venduta franco destino; la spedizione sarà effettuata nel modo più opportuno senza che ciò possa dar luogo a reclami di sorta. Non saranno accettati reclami per ritardi, guasti, ammacchi che possano verificarsi in viaggio per qualsiasi causa e spetta comunque al committente fare gli eventuali reclami nei confronti dei vettori responsabili.

## **RECLAMI**

La merce deve essere verificata alla consegna; eventuali reclami saranno tenuti in considerazione se fatti tramite lettera raccomandata entro otto giorni dalla consegna. Se per qualsiasi motivo dovesse sorgere una qualsivoglia controversia in dipendenza delle

ordinazioni assunte o forniture da noi eseguite è espressamente convenuto che si dovrà adire esclusivamente alla competenza del Tribunale di Novara.

## **PAGAMENTI**

I pagamenti delle fatture sono validi e liberatori se eseguiti direttamente al nostro domicilio per contanti netto, salvo accordi diversi. Ogni altro tipo di pagamento è effettuato a rischio e pericolo del cliente. In caso di ritardo di pagamento, sulle cifre ancora scoperte decorreranno gli interessi di mora e sarà nostra facoltà emettere tratta a saldo di quanto dovuto, senza che il cliente possa sollevare obiezioni di sorta. Qualora i pagamenti non siano effettuati anche solo in parte, la merce rimane di nostra proprietà sino al saldo totale della fattura; in tal caso è nostra facoltà sospendere le consegne in corso e annullare i restanti ordini.

## **GARANZIA**

Tutti i nostri articoli sono accuratamente provati, controllati e garantiti per cinque anni dalla data della fatturazione. La nostra responsabilità si limita nell'accettare il ritorno della merce, franco di porto e sostituirne i pezzi eventualmente riscontrati difettosi, senza perciò essere tenuti ad alcun indennizzo per danni causati da difetti di fabbricazione. Non possiamo inoltre accettare alcuna responsabilità per difetti che risultassero da eventuali manomissioni dei materiali da noi forniti. Inoltre la nostra responsabilità cessa qualora il cliente non abbia osservato le condizioni di pagamento indicate sulla nostra fattura.

IL PRESENTE LISTINO ANNULLA E  
SOSTITUISCE I PRECEDENTI



# general sales conditions

## **PRICES**

Our quotations are subject to alteration and are not binding without our confirmation. These are for goods delivered Ex-Works Pogno, package not included.

## **ORDERS**

The orders received by letter, fax or by means of agents are valid after our signed confirmation. Concerning orders, the customer fully and tacitly accepts all our sales terms.

## **DELIVERY**

Delivery terms are approximate and not binding and don't forgive the right to the purchaser to cancel the order or claim for damages occurred during manufacturing, storage of raw materials, strikes, stoppages, delay in transport or other circumstances beyond our control.

Goods are carried at customer's risk even if are delivered free of carriage. We are not responsible for any delay, breakage or deficit it may occur.

## **CLAIMS**

Goods have to be tested from the buyer after delivery and claims will be accepted if presented by registered seller not later than 8 days from the delivery of the goods. For any controversy that may arise, the 2 Partners are compelled to apply to the Court of Law of Novara.

## **PAYMENTS**

The payment shall be effected at our domicile, by cash, unless a special agreement of deferred payment. The seller may postpone the fulfillment of his own obligation until such payment is made. The goods remains of our property until the total payment of our invoices, being understood the obligation to send totally back the same even if invoice has been partially paid.

## **GUARANTEE**

All our articles are always carefully tested and they have a 5 years guarantee. Returns of goods are acceptable but the cost of transport to be buyer's account. Damaged items are replaced only after a verify that no tampering have been made. Our responsibility ends when the customer does not observe the terms of payment indicated on invoice.

THIS PRICE-LIST CANCELS AND REPLACES THE PREVIOUS ONES

**Il presente catalogo annulla e sostituisce i precedenti.**  
This catalogue cancel and replace all the previous ones.

**La Rubinetteria Pains S.p.A.,  
si riserva il diritto di apportare a propria discrezione modifiche ai prodotti,  
ai dati tecnici e alle informazioni commerciali.**

Rubinetteria Pains S.p.A.,  
reserves the right to modify as its discretion, changes on products,  
on technical and commercial information.





*Paini*

**PAINI S.p.A. Rubinetterie**

via Cremosina, 43  
28076 Poggio NO - Italy  
tel. +39 0322 9971  
fax +39 0322 997300

[www.paini.com](http://www.paini.com) - [paini@paini.com](mailto:paini@paini.com)