



COLORS

BY VITRUVIT



Vitruvit

COLORS

BY VITRUVIT

Sfumature ocra, grigi seducenti, venature sinuose, colori brillanti, sono queste le caratteristiche della linea **COLORS** di Vitruvit. Ispirata alle nuance della natura, una gamma di colori caldi e contemporanei che sposano l'innovazione tecnologica della monocottura a 1250°.

Shades of ochre, seductive greys, sinuous veins, bright colours, these are the characteristics of **COLORS**, the line by Vitruvit. A range of warm and contemporary colours inspired by natural nuances that embrace the technological innovation of 1250° single firing.

Цветовая палитра охры, впечатляющие оттенки серого, нежный рисунок, сверкающие поверхности - это характеристики линии **COLORS** от Vitruvit. Наваянная красотой природы, палитра теплых современных цветов сочетается с техническими инновациями одинарного обжига при температуре 1250°.



« COLORI BRILLANTI E FINITURE SATINATE, UN'AMPIA GAMMA DI COLORI CHE TRAE ISPIRAZIONI DALLE SFUMATURE DELLE PIETRE NATURALI. »

Bright colours and glossy finishes, a wide range of colours that take inspiration from the different nuances of natural stones.

яркие цвета и мягкий блеск полированной поверхности... богатая цветовая палитра, навеянная оттенками натурального камня.

INDEX

VITRUVIT COLORS

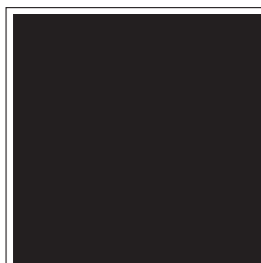

Black
P. 07



White
P. 11

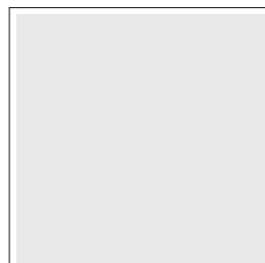

White Agate
P. 15

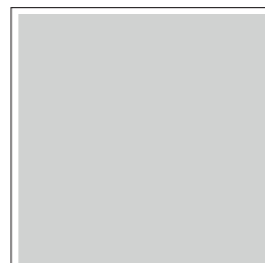

Naxos
P. 19



Quartz
P. 23



Grey Agate
P. 27



Graphite
P. 31



Natural Stone
P. 35

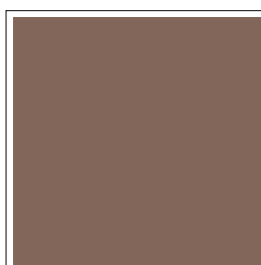

Gravel
P. 39



Taos
P. 43

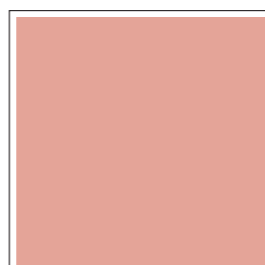

Morganite
P. 47



Coral
P. 51



Amazzonite
P. 55



Ocean Jasper
P. 59



Gold Matt
P. 63



Platinum Matt
P. 67

Monocottura P. 70

I nostri colori P. 72

Area Tecnica P. 74

Condizioni generali di vendita P. 76

Black

Black

VITRUVIT COLORS

Profondo, seducente, elegante, perfetto in qualsiasi contesto per la sua sobrietà e al tempo stesso per la sua forte presenza.

Deep, seductive, elegant, perfect in any context thanks to its sobriety as well as its powerful presence.

Глубокий и волнующий, одновременно скромный и властный, и поэтому совершенный в любом контексте.





Black

Sovereign lavabo 48cm
Sovereign washbasin 48cm
Sovereign умывальник 48cm

White

White

VITRUVIT COLORS

Delicato, puro. In contesti moderni o classici, il bianco lucido è sempre protagonista indiscusso di ogni ambiente.

Delicate, pure, ethereal. In modern or classic contexts, white is always the main protagonist in every space.

Мягкий, чистый, эфирный. В современном или классическом контексте белый цвет всегда является неоспоримым участником любой обстановки.





White

Sovereign lavabo 48cm
Sovereign washbasin 48cm
Sovereign умывальник 48cm



White Agate

VITRUVIT COLORS

White Agate



Pietra sinonimo di equilibrio ed energia, nella sua varietà bianca si caratterizza per il suo senso di purezza.

A stone synonymous with balance and energy, in white it stands out for its purity.

Многочисленные оттенки белого в камне, символизирующем равновесие и энергию, дают ощущение чистоты.



White Agate

Sovereign lavabo 48cm
Sovereign washbasin 48cm
Sovereign умівальник 48cm

Naxos

Naxos

VITRUVIT COLORS

Ispirata alle costruzioni dei popoli antichi, il colore di questa pietra richiama la luce e la freschezza degli antichi splendori.

Inspired by the buildings of ancient populations, the colour of this stone evokes the light and freshness of ancient marvels.

Цвет этого камня, навеянный строениями древних цивилизаций, напоминает о блеске неувядающего древнего великолепия.



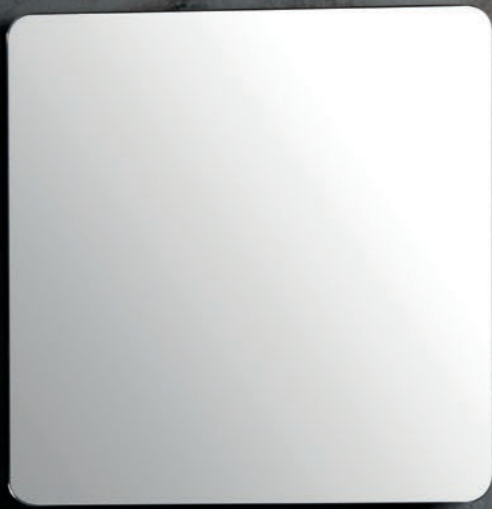

Naxos

Old Time lavabo 50cm
Old Time washbasin 50cm
Old time умывальник 50cm

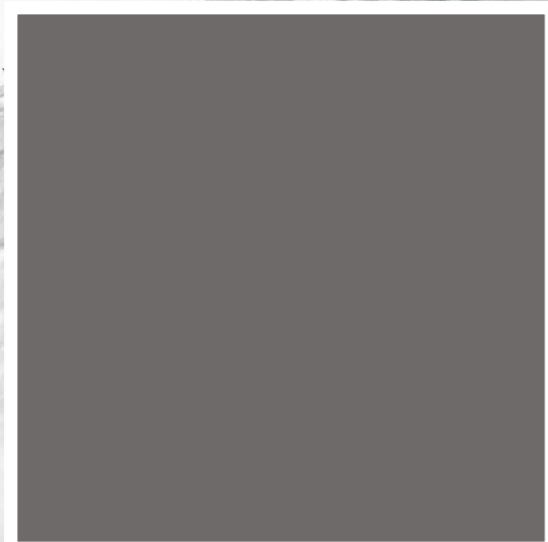

Quartz

VITRUVIT COLORS

Quartz



Pietra dalla forte energia, rappresenta l'unione tra le forze spirituali e terrene, allontanando le sensazioni negative a favore di quelle positive.

A stone with a strong energy, representing the combination of spiritual and earthly powers, that keeps away negative feelings and attracts positive ones.

Сильная энергетика камня отражает союз духовных и земных сил, отгоняя отрицательные эмоции и притягивая положительные.

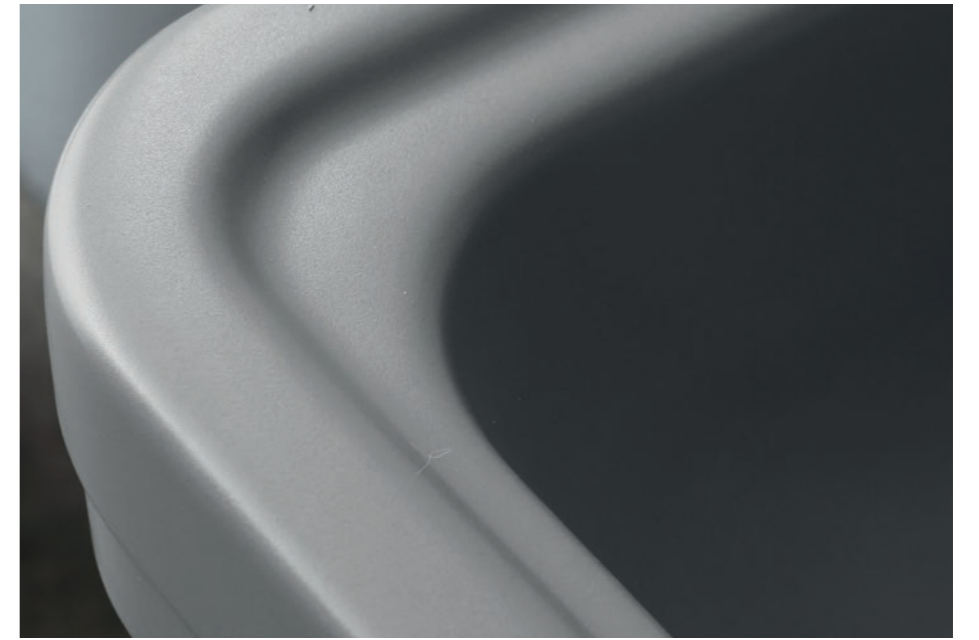

Quartz

Albano colonna 50cm
Albano pedestal 50cm
Albano пьедестал 50cm

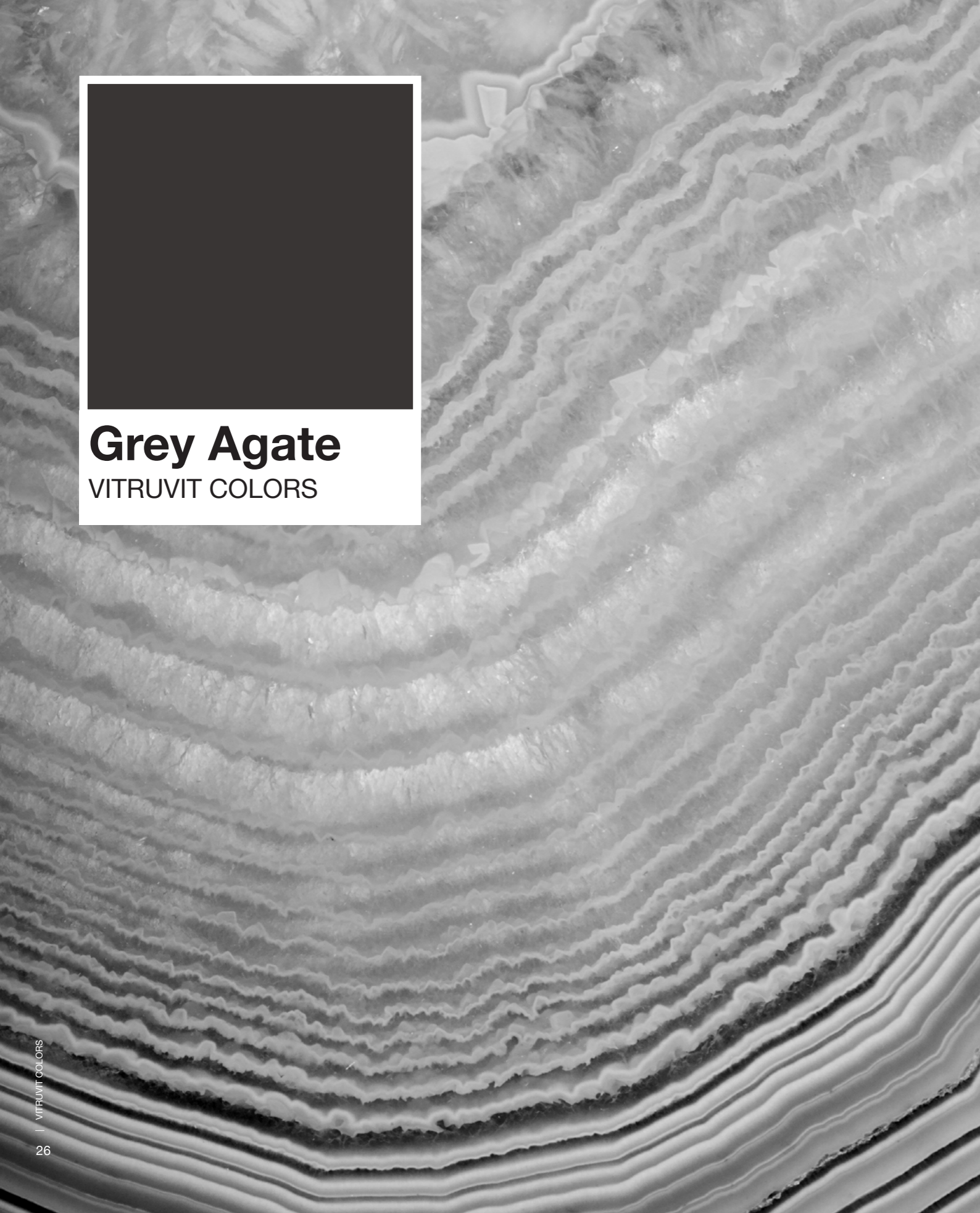

Grey Agate
VITRUVIT COLORS

Grey Agate



Pietra elegante votata alla semplicità e all'introspezione, promuove l'intimità e l'equilibrio.

An elegant stone devoted to simplicity and introspection, it promotes intimacy and balance.

Элегантный камень, олицетворяющий простоту и самосозерцание, дает начало простоте и равновесию.



Grey Agate

Albano lavabo 50cm
Albano washbasin 50cm
Albano умывальник 50cm

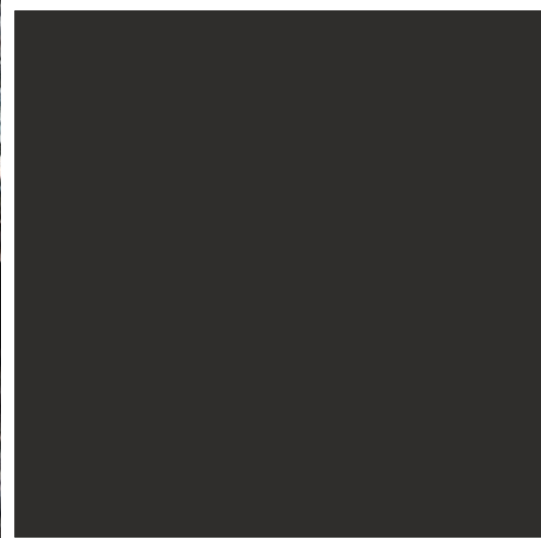

Graphite

VITRUVIT COLORS

Graphite



Minerale dal colore scuro ma caratterizzato da molteplici sfumature date dalla lucentezza metallica e la trasparenza opaca.

A dark coloured mineral characterised by multiple nuances derived from the metallic shine and opaque transparency.

Минерал темного цвета, но богатый оттенками, созданными из металлического блеска и матовой прозрачности.



Graphite

Albano colonna 50cm
Albano pedestal 50cm
Albano пьедестал 50cm

Natural Stone

Natural Stone

VITRUVIT COLORS

Materiale di costruzione tra i più antichi. La straordinaria resistenza e la varietà di toni che lo caratterizzano, lo rendono adatto sia come materiale costruttivo che decorativo.

One of the oldest building materials. The extraordinary strength and variety of the different tones that characterise it, make it suitable both as a building and a decorative material.

Один из древнейших строительных материалов. Необычная прочность и разнообразие оттенков делают этот минерал идеальным строительным и отделочным материалом.





Natural Stone

Old Time lavabo 50cm
Old Time washbasin 50cm
Old time умывальник 50cm

Gravel

Gravel

VITRUVIT COLORS

Proveniente dalla frantumazione della roccia, la levigatura dell'acqua ne esalta le caratteristiche estetiche e le varietà tonali di cui è dotata.

Derived from fragmented rock, the smoothing effect of water enhances its aesthetic characteristics and its variety of shades of colour.

Продукт дробления скальных пород, отшлифованный водой, которая усилила его эстетические характеристики и богатство оттенков.





Gravel
Sovereign lavabo 48cm
Sovereign washbasin 48cm
Sovereign умівальник 48cm

Taos

Taos

VITRUVIT COLORS

Ispirata alle tipiche costruzioni in fango delle città messicane, la bellezza delle sfumature ocra che le caratterizza le fondono col paesaggio, come se emergessero naturalmente dalla terra.

Inspired by traditional Mexican mud buildings, the beauty of their characteristic shades of ochre allow them to blend in with the landscape, as if they emerged naturally from the ground.

Красота охристых оттенков навеяна образом типичных глиняных построек мексиканских городов, которые, сливаясь с ландшафтом, как будто естественным образом выросли из земли.





Taos

Albano colonna 50cm
Albano pedestal 50cm
Albano пьедестал 50cm

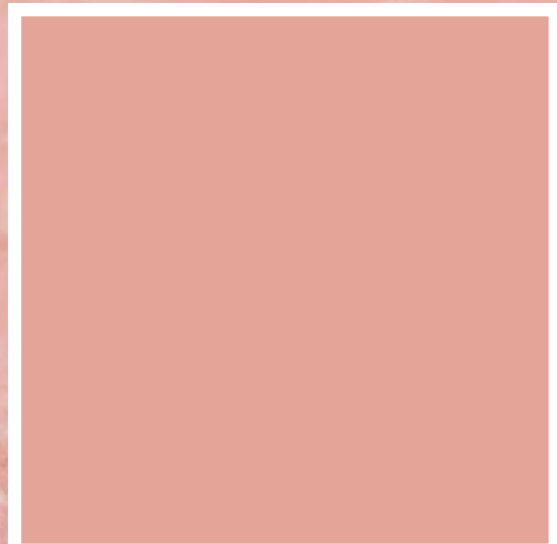

Morganite
VITRUVIT COLORS

Morganite



Stupenda pietra rosa, dalle delicate sfumature, preziosa ed elegante ben si adatta a diverse esigenze di stile.

A beautiful pink stone, with delicate nuances, precious and elegant, it suits all different styles seamlessly.

Удивительный розовый камень с нежными оттенками, прекрасный и элегантный, хорошо удовлетворяет любые требования стиля.



Morganite

Albano colonna 50cm
Albano pedestal 50cm
Albano пьедестал 50cm

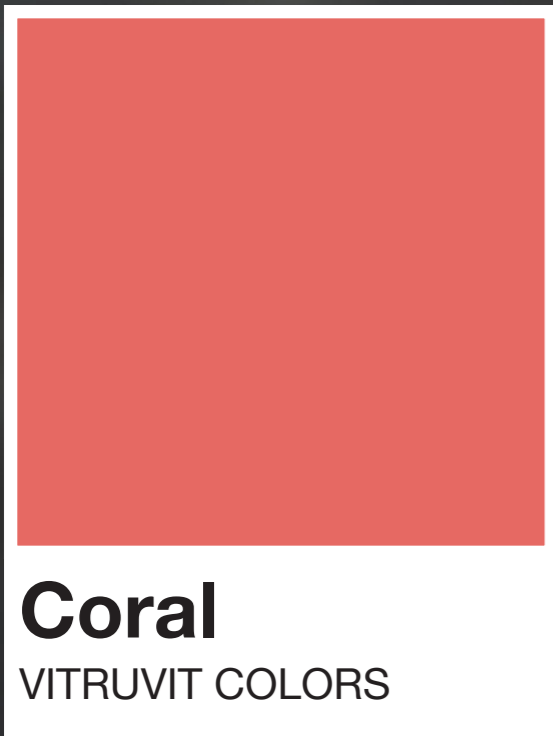

Coral
VITRUVIT COLORS



Coral



Chi lo associa a miti e storie fantastiche, chi lo considera un porta-fortuna, il corallo racchiude un indiscutibile fascino al quale è difficile resistere.

To some it evokes myths and fantastic stories, others consider it a lucky charm. Coral's indisputable appeal is hard to resist.

Кто-то связывает его с мифами и фантастическими историями, кто-то считает его талисманом - коралл заключает в себе неоспоримое обаяние, перед которым трудно устоять.



Coral

Old Time lavabo 50cm
Old Time washbasin 50cm
Old time умывальник 50cm

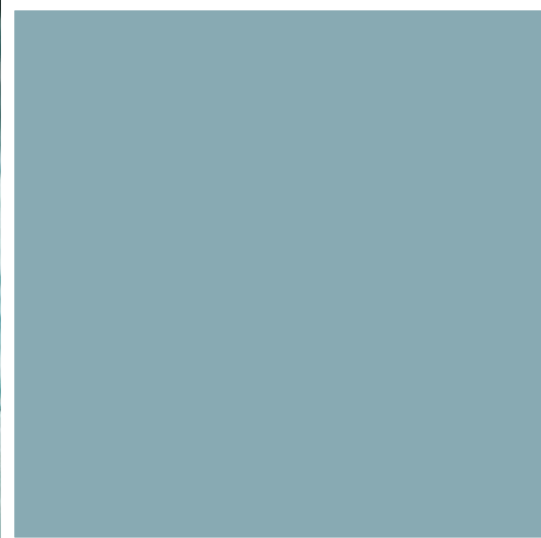

Amazzonite
VITRUVIT COLORS

Amazzonite



Chiamata "pietra della speranza" il bel colore verde e le sfumature cristalline ricordano la profondità del mare.

Also known as the "stone of hope", its beautiful green colour and crystal nuances evoke the depth of the sea.

Камень под названием «камень надежды»: красивый зеленый цвет и прозрачные оттенки напоминают морские глубины.



Amazzonite

Old Time lavabo 50cm
Old Time washbasin 50cm
Old time умывальник 50cm

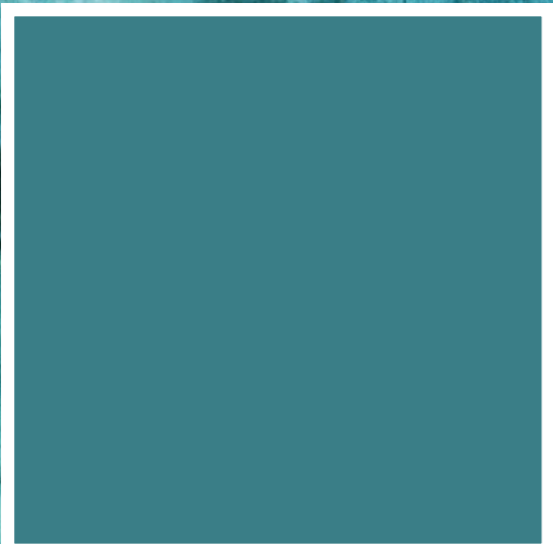

Ocean Jasper

VITRUVIT COLORS

Ocean Jasper



Pietra magnifica, apprezzata per le particolarissime colorazioni e sfumature, "oceanica" perché solo con la bassa marea è possibile estrarla.

A magnificent stone, appreciated for its unique shades of colour and nuances, "oceanic" because it can be extracted only when the tide is low.

Великолепный камень, известный благодаря особой расцветке и оттенкам; «океанический», поскольку достать его можно только во время отлива.



Ocean Jasper

Sovereign lavabo 48cm
Sovereign washbasin 48cm
Sovereign умывальник 48cm

Gold Matt



Gold Matt
VITRUVIT COLORS

Tra i metalli più amati, ricercati e senza dubbio sinonimo di eleganza e lusso per eccellenza.

One of the most popular and sought-after metals and synonymous of elegance and luxury par excellence.

Относится к наиболее востребованным металлам и, несомненно, является синонимом элегантности и роскоши.





Gold Matt

Sovereign colonna 48cm
Sovereign pedestal 48cm
Sovereign пьедестал 48cm





Platinum Matt
VITRUVIT COLORS



Platinum Matt

Metallo di color bianco argenteo assai raro in natura, oggi tra i tre metalli più preziosi apprezzato per la sua resistenza e la sua eleganza.

Silvery white metal very rare, one of the three most precious and appreciated metals thanks to its strength and elegance.

Металл серебристо белого цвета, очень редко встречающийся в природе, сегодня относится к наиболее ценным металлам благодаря прочности и элегантности.





Platinum Matt

Old Time colonna 50cm
Old Time pedestal 50cm
Old time пьедестал 50cm

MONOCOTTURA

«**COLORS** BY VITRUVIT PROPONE UNA GAMMA DI COLORI ISPIRATI ALLA NATURA E REALIZZATI CON UNA TECNICA DI SMALTATURA CHE AVVIENE IN **PRIMA ED UNICA COTTURA A 1250°** E NON NECESSITA QUINDI DI ULTERIORE COTTURA.»



«L'UTILIZZO DI UN SOLO TRATTAMENTO TERMICO SI TRADUCE IN **MAGGIOR QUALITÀ E BRILLANTEZZA**. INOLTRE GARANTISCE MAGGIOR RESISTENZA ALL'USURA ED AGLI SBALZI TERMICI E NE FACILITA LA PULIZIA.»

METODO NORMALMENTE UTILIZZATO

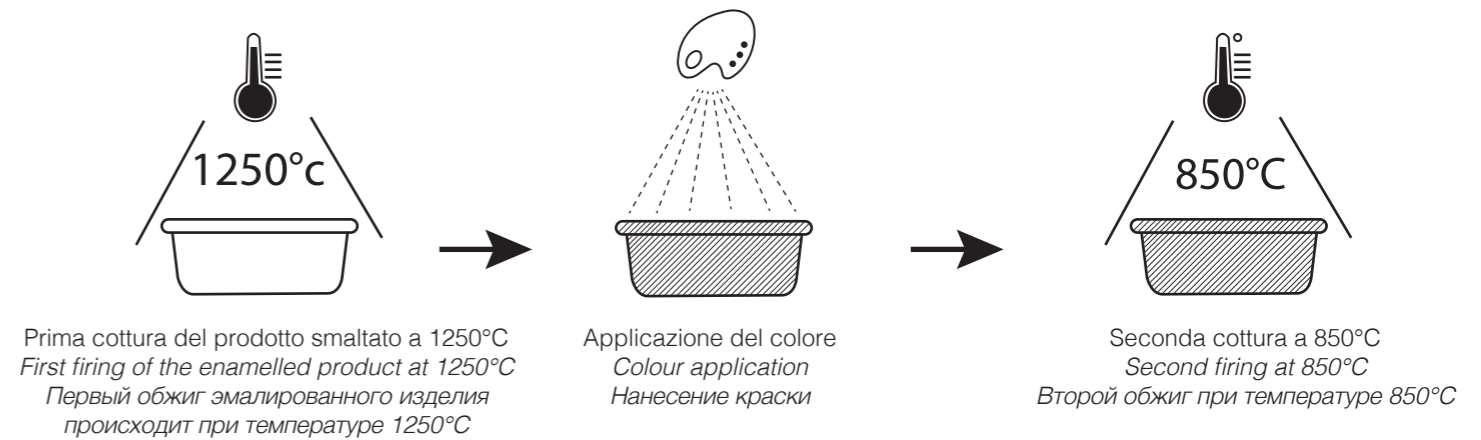

MONOCOTTURA

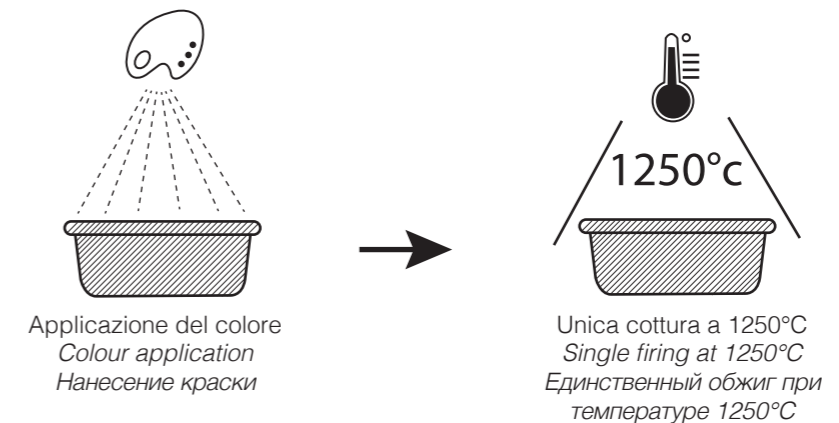

COLORS by Vitruvit offers a range of colours inspired by nature and created using a spray technique that is subject to **1250° single firing** and therefore does not require further heat treatments.

The use of a single heat treatment translates into **higher quality and brightness**. It also guarantees greater resistance to use and sudden temperature changes making it easier to clean.

Collezione **COLORS** от vitruvit предлагает цветовую гамму, навеянную природой и полученную благодаря технике распыления, применяемой во время первого и **единственного обжига при температуре 1250°** и не требующей дополнительного обжига

Применение только одной термической обработки означает **более высокое качество и блеск**. Кроме того, гарантирует большую стойкость к износу и перепадам температур, облегчает очистку.

I NOSTRI COLORI

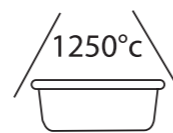

MONOCOTTURA 1250°C
SINGLE FIRED 1250 ° C
ОДИН ОГОНЬ 1250 ° C

Strong finishes, glossy, with a **pleasant feel** and bright enamelling are the result of a research aimed at creating **quality and long-lasting products**.

COLORS by Vitruvit, has **14 matt colours** (in addition to white and black satin) with more to come.

Прочные отделки с эффектом мягкого блеска, **приятная на прикосновение поверхность** – это результат поисков, направленных на создание качественного и **долговечного изделия**. Коллекция COLORS by Vitruvit включает **14 матовых цветов** (в дополнение к белому и черному глянцевому) и до сих пор пополняется новыми образцами.

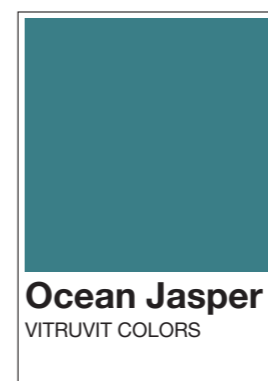
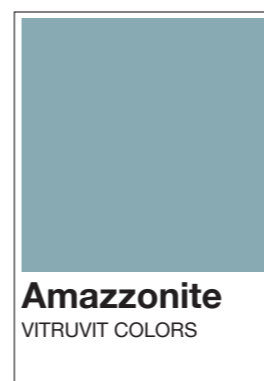
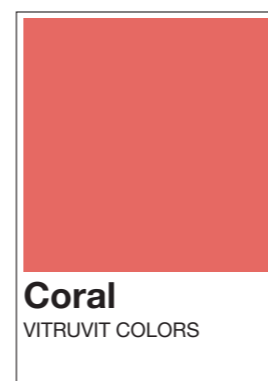
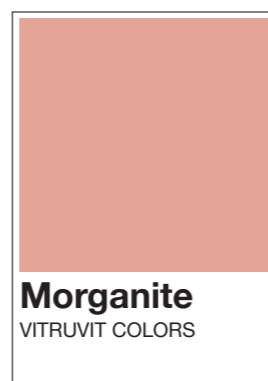
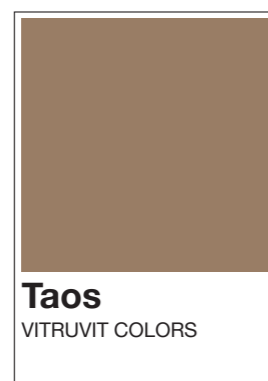
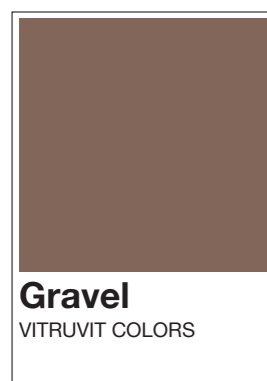
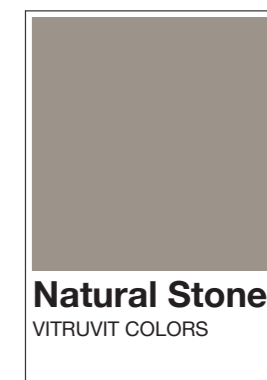
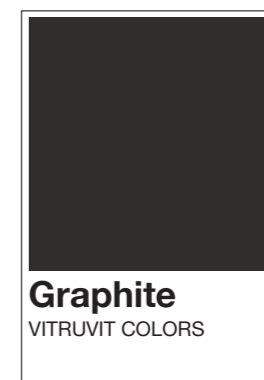
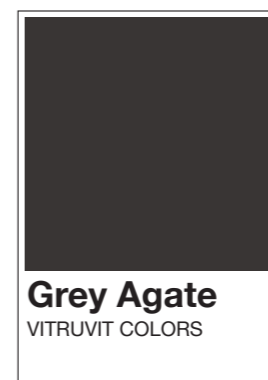
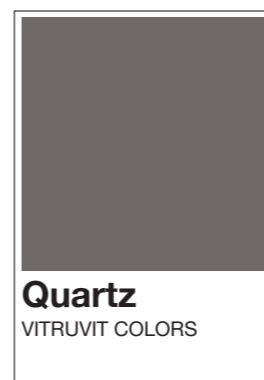
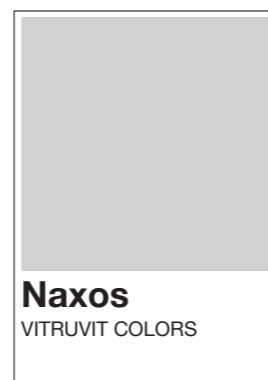
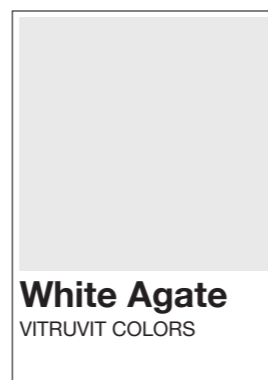
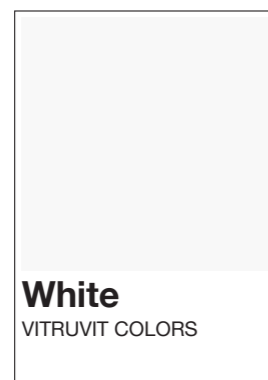
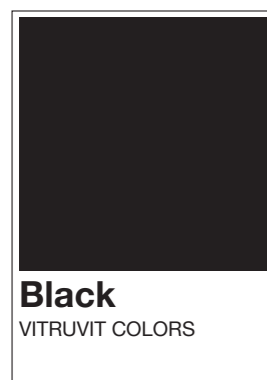

FINITURE RESISTENTI, SATINATE, DAL PIACEVOLE **EFFETTO TOUCH** E SMALTI BRILLANTI SONO FRUTTO DI UNA RICERCA FINALIZZATA A CREARE PRODOTTI DI **QUALITÀ, DUREVOLI NEL TEMPO**. COLORS BY VITRUVIT, COMPRENDE **14 COLORI MATT** (OLTRE AL BIANCO E NERO LUCIDO) ED È TUTT'ORA IN EVOLUZIONE.

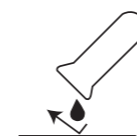

RESISTENZA AGLI AGENTI CHIMICI
RESISTANCE TO CHEMICALS
УСТОЙЧИВОСТЬ К ДЕЙСТВИЮ ХИМИЧЕСКИХ АГЕНТОВ



FACILITÀ DI PULIZIA
EASY TO CLEAN
ЛЕГКОСТЬ ОЧИСТКИ



RESISTENZA AGLI SBALZI TERMICI
RESISTANCE TO SUDDEN TEMPERATURE CHANGES
УСТОЙЧИВОСТЬ К ПЕРЕПАДАМ ТЕМПЕРАТУР



AMPIA SCELTA DI COLORI
VAST CHOICE OF COLOURS
ШИРОКАЯ ЦВЕТОВАЯ ГАММА

AREA TECNICA

Albano 50

Lavabo 50cm
Washbasin 50cm
Умывальник 50cm

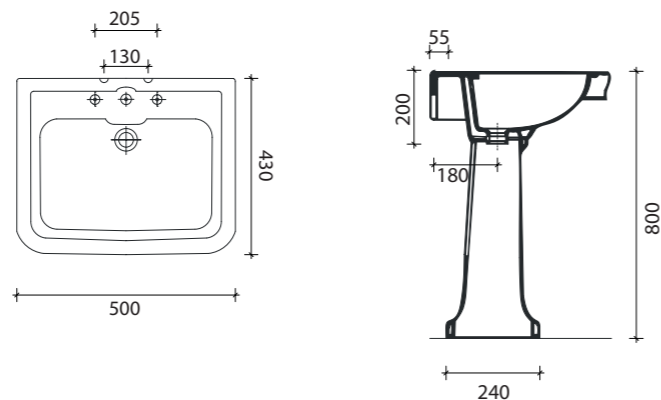

Old Time 50

Lavabo 50cm
Washbasin 50cm
Умывальник 50cm

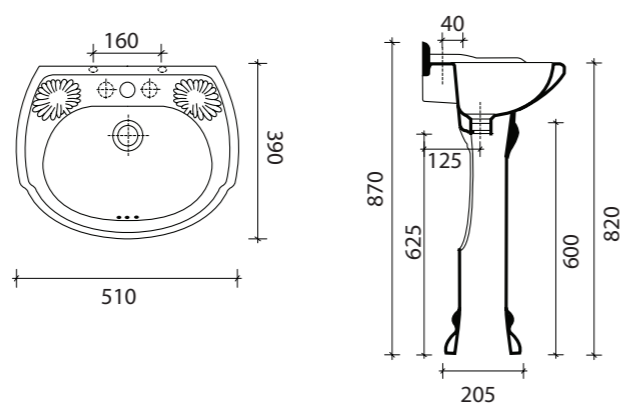

Sovereign 48

Lavabo 48cm
Washbasin 48cm
Умывальник 48cm

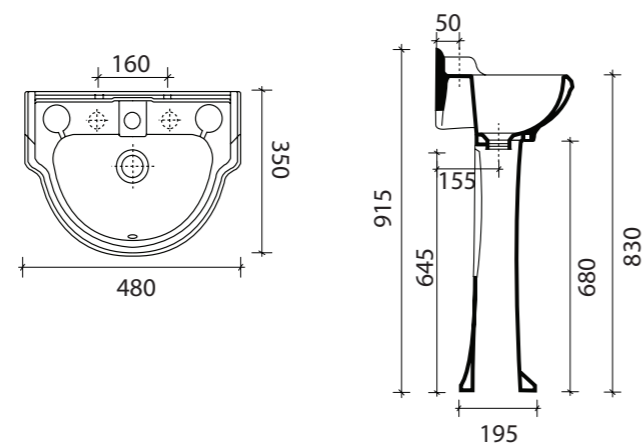

HAI BISOGNO DI AIUTO?

NEED HELP? НУЖНА ПОМОЩЬ?

Se necessiti di maggiori informazioni riguardo i nostri prodotti o hai bisogno di aiuto ad ordinare un articolo, chiamaci o scrivici:

If you need info about our products or you need help to order an item, call us or send us an email:

Если Вам необходима дополнительная информация о наших изделиях или нужна помощь, чтобы заказать товар, звоните или напишите:

Tel. / Phone / Телефон:
+39.0761.540738

Mail / Mail / Почта:
info@vitruvit.it



I colori e le finiture illustrate nel presente catalogo sono da ritenersi puramente indicative. Le misure presenti sono aggiornate al momento della stampa del catalogo, pertanto i dati elencati possono subire variazioni.

The colours and decorations illustrated in this catalogue are to be regarded as mere indications. The details present are updated at the time the catalogue is printed, therefore the datas may change.

Цвета и отделки, приведенные в каталоге, должны рассматриваться как ориентировочные. Приведенные размеры обновлены в момент печати каталога, поэтому представленные данные могут быть изменены.

CONDIZIONI GENERALI DI VENDITA

- 1) Accettazione ordini: l'ordine è sempre subordinato all'approvazione del produttore. Le condizioni di vendita si intendono accettate dal committente al momento del conferimento dell'ordine e con il ritiro del materiale.
- 2) Consegne e rese: la merce è resa franco deposito di partenza e viaggia a rischio e pericolo del committente. Il venditore si riserva di poter effettuare consegne parziali
- 3) Spedizioni e tempi di consegna: Le quantità devono essere verificate all'atto del ricevimento ed eventuali discordanze devono essere annotate sulla bolla di consegna mediante accettazione con riserva di controllo. I tempi di consegna verranno comunicati dal produttore in fase di ordine e sono forniti a titolo informativo e non vincolante.
- 4) Imballaggio: L'imballaggio è su scatole e/o su pallet ed è a carico del committente. Eventuali addebiti per imballi particolari saranno comunicati dal produttore in fase di ordine.
- 5) Reclami e responsabilità: I reclami devono pervenire entro 7 giorni dalla data di consegna della merce ed eventuali resi devono essere preventivamente approvati dal produttore. Il produttore non fornisce garanzie circa l'impiego errato e/o manutenzione inadeguata dei prodotti (vedere punto 6). In caso di difetti di fabbrica, riconosciuti ed approvati dal produttore, lo stesso si riserva la facoltà di sostituire o accreditare il valore senza che questo si possa estendere in nessun caso ad altri oneri.
- 6) Pulizia e la manutenzione: per la pulizia si consiglia vivamente l'uso di prodotti non aggressivi, che possono alterare o danneggiare le finiture. Il produttore non accetta in alcun modo reclami per difetti causati da impropria manutenzione
- 7) Foro: per qualsiasi controversia il Foro competente è quello di Viterbo.

GENERAL SALES TERMS

- 1) Order acceptance: The order is always subject to approval of the seller.
- 2) Deliveries: The goods are delivered Ex Factory and travel on buyer's own risk. The seller reserves the right to execute partial consignments.
- 3) Forwarding and delivery time: The quantities must be checked upon receipt of the goods and any complaint must be made to the courier. Any additional cost applied by the courier will be charged to the buyer. The delivery time is always given as information and it never has to be considered as binding.
- 4) Packaging: Packaging is standard in boxes and/or pallets. Any additional cost for particular packaging will be charged to the buyer.
- 5) Complaints and liability: Complaints are not accepted after a period of seven days from the consignment of the goods and return of the goods must be authorized in advance by the seller. The seller does not provide a guarantee covering incorrect use and/or improper maintenance (point 6). Eventual manufacturing faults must be admitted and approved by the seller, whom reserves the right to replace material or to credit the value to the buyer. Under no circumstances does the company's liability extend to the payment of direct or indirect charges for other things.
- 6) Cleaning and maintenance: the sellers strongly advise the use of non-aggressive products for the cleaning of the products, that may damage the decorations. Under no circumstances does the seller accept claims or returns for improper cleaning or maintenance.
- 7) Competent court of law: for any controversy that may rise, the competent court law is the one in Viterbo.

ОБЩИЕ УСЛОВИЯ ПРОДАЖИ

- 1) Принятие заказов: заказ всегда подлежит утверждению со стороны производителя. Условия продажи считаются принятыми заказчиком во время размещения заказа и получения товара.
- 2) Доставка и возврат: товар возвращается на условиях франко-депозит отправки и транспортируется на риск и под ответственность заказчика. Продавец оставляет за собой право на частичные поставки.
- 3) Отправка и сроки доставки: Количество изделий должно проверяться при получении, а возможные несоответствия должны быть записаны в накладной; в данном случае товар принимается с оговоркой контроля. Сроки поставки объявляются производителем на этапе заказа в целях информирования и не являются обязывающими.
- 4) Упаковка: Товар упаковывается в коробки и / или на поддоны, которые относятся на счет клиента. О любой сумме, взимаемой за специальную упаковку, производитель сообщает клиенту во время заказа.
- 5) Претензии и ответственность: Претензии должны быть получены в течение 7 дней с момента доставки товара и любые возвращения должны быть согласованы с производителем. Производитель не дает никаких гарантий относительно неправильного использования и / или недостаточного ухода за изделиями (см. пункт 6). В случае производственных дефектов, признанных производителем, последний оставляет за собой право заменить товар или вернуть стоимость товара без принятия каких-либо других обязательств.
- 6) Очистка и обслуживание: для очистки категорически не рекомендуется использование агрессивных продуктов, которые могут изменить или повредить отделку. Производитель не принимает каких-либо претензий за дефекты, вызванные неправильным обслуживанием.
- 7) Суд: для разрешения любых споров компетентным является суд г. Витербо.

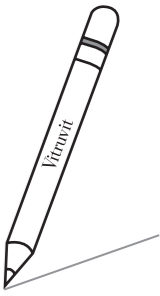
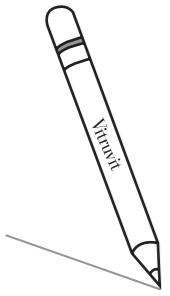

Lined writing area on page 78.

Lined writing area on page 79.

CREDITS

PHOTO
studioventuno.eu

GRAPHIC DESIGN
studioventuno.eu

APRIL 2019

**Ocean Jasper
Amazzonite
Coral
Morganite
Taos
Gravel
Natural Stone
Graphite
Grey Agate
Quartz
Naxos
White Agate
Gold Matt
Platinum Matt
Black
White**



Loc. Prataroni Z.I.
01033 Civita Castellana (VT) - Italia
T: +39.0761.540738
info@vitruvit.it

Vitruvit