

ever
LIFE DESIGN

INDICE

Index

- **Now and Ever**
now and ever pg. 2
- **Prodotti**
products pg. 4
- **Tabelle di conversione**
conversion tables pg. 249

NOW

AND

EVER

Impegnata da sempre nel produrre e diffondere i valori della sicurezza e del comfort nella produzione di dispositivi e complementi, Thermomat lancia con EVER LIFE DESIGN una nuova sfida volta alla ridefinizione di uno spazio importante come il bagno. EVER LIFE DESIGN, pur tenendo conto delle necessità quotidiane che cambiano e assumono specifiche peculiarità, si identifica con l'idea che nelle diverse età della vita si possano continuare ad utilizzare sia lo stesso luogo sia lo stesso arredamento, se scelto con attenzione. Un luogo in cui far convivere figli piccoli, adulti e persone anziane con le loro necessità da soddisfare, oltre alla riscoperta e difesa della valorizzazione del "sé" che non deve mai andare perduto in qualsiasi momento della propria vita.

Always committed to creating and spreading the values of safety and comfort in the production of devices and accessories, Thermomat, with EVER LIFE DESIGN, launches a new challenge with a view to redefining such an important room like the bathroom. EVER LIFE DESIGN, even taking into account the daily needs that change and take on specific characteristics, identifies itself with the idea that, at different ages, people can go on using the same place and the same furniture, if chosen carefully.

A place where children, adults and elderly people can live side by side with their own different needs, that must be satisfied, as well as the rediscovery and defense of the enhancement of the "self" that should never be lost in each moment of one's life.



◦ **Barre, portasciugamani** bar, towel holders



DOT
collection

pg. 7

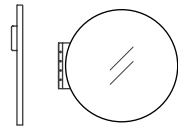

PROP
collection

pg. 29



SHINE
collection

pg. 43



FEEL
collection

pg. 53

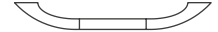

STYLE
collection

pg. 61

◦ **Mensole** shelves

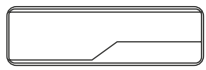

BRUNT
collection

pg. 73

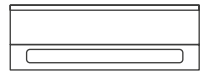

LISSOM
collection

pg. 85



GAMBOL

pg. 95



STREET

pg. 105

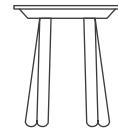

RUNG
collection

pg. 113

◦ **Complementi** extras

◦ **Lavabi** washbasins

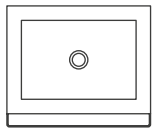

LINK

pg. 127

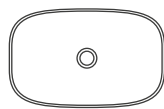

BOUNCE

pg. 139

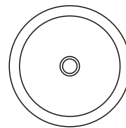

STONY

pg. 153

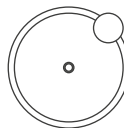

BOING

pg. 161

PRODOTTI Products

◦ Sanitari sanitary ware



EASY 42

pg. 171

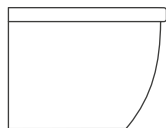

EVERY 44

pg. 179

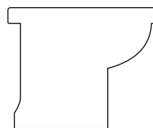

SENIOR 46

pg. 189

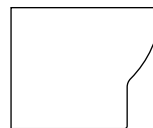

STYLE 47

pg. 195

◦ Sedili e piatti doccia shower seats and trays

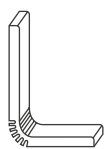

TUCK
collection

pg. 201

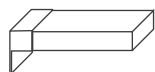

STYLE
collection

pg. 215



T-STONE

pg. 221

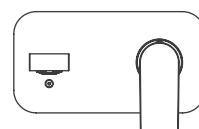

RUBINETTI
taps

pg. 229

◦ Accessori accessories



RING

pg. 237

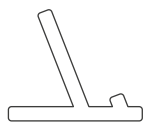

I-PAD STAND

pg. 239

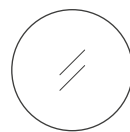

SPECCHI
mirrors

pg. 241



PORTASCPINI
toilet brush holders

pg. 243

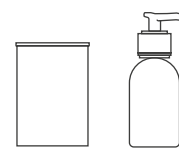

BICCHIERI e
DISPENSER

pg. 245

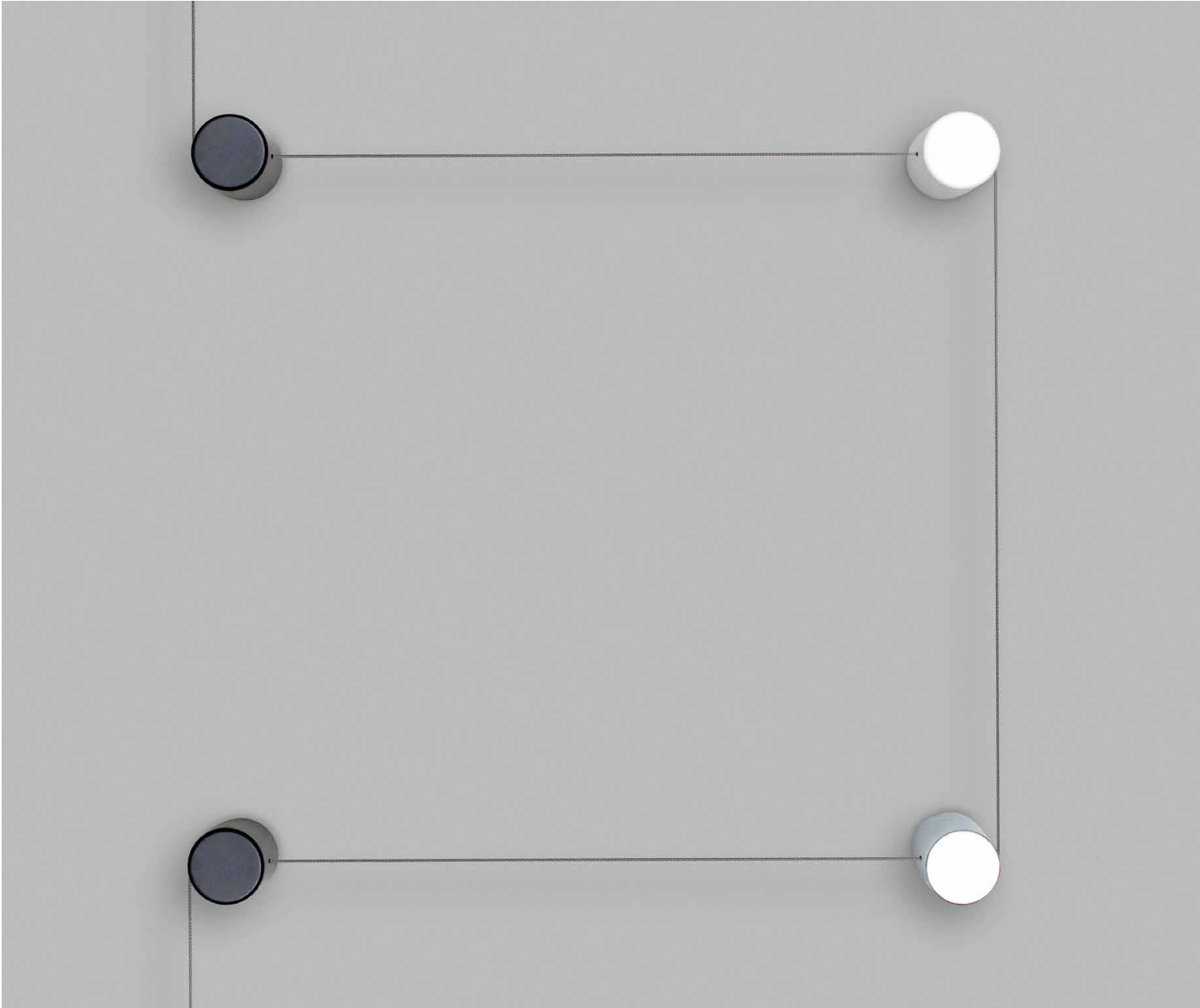

sistema modulare multifunzione per il bagno e la casa **multifunction modular system for bath and home**



D O T

.....

Design

Monica
Graffeo

.....





portasalviette
towel holder



Una collezione di complementi e accessori modulari e multifunzione, dallo spirito democratico.

Eleganza nel dettaglio, materiali non convenzionali, funzionalità versatile e trasversale, sono gli elementi che caratterizzano DOT.

.....

A collection of modular and multifunctional accessories and complements, with a democratic spirit.

Elegant details, unconventional materials, versatile and cross functionality, these are the features of DOT.

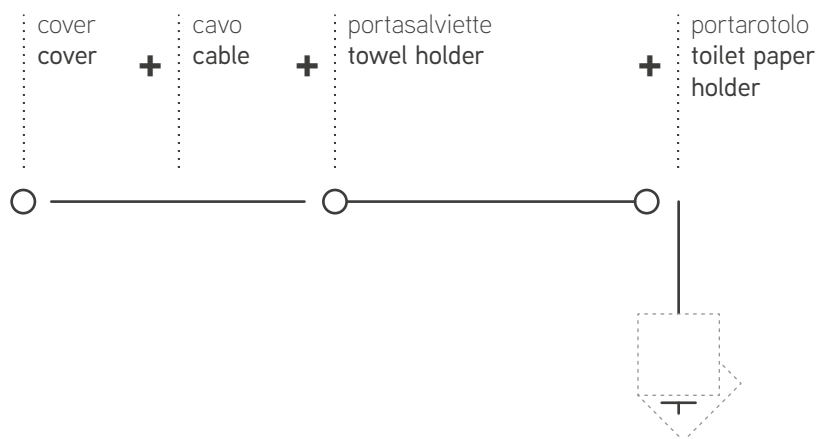

DOT risolve gli spazi più piccoli così come le sale da bagno più spaziose, grazie all'attenta progettazione e all'industrializzazione degli elementi che la compongono: un sottile ma resistente cavetto d'acciaio scorre all'interno di solidi appigli cilindrici, fissati a muro.

.....

DOT is suitable to be used both in narrow spaces and spacious bathrooms, thanks to a careful design and to the technical features of this new line: a thin but resistant steel rope, sliding inside cylindrical solid body, fixed to the wall.

D O T





D O T

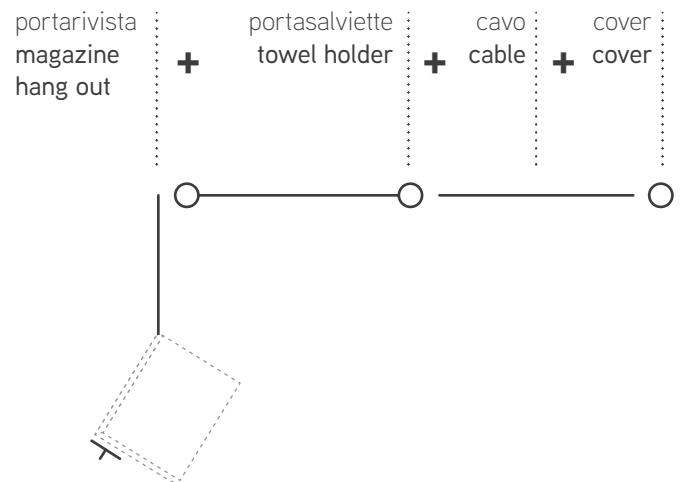

Totale libertà di configurazione.
 Il cavo funge da portasalviette per lavabo e bidet, ma è anche spazio utile per appendere altri accessori.

.....

Feel free to choose your configuration.
 The steel rope becomes a towel holder for the washbasin and the bidet, but it is also a useful space where you can hang other accessories.

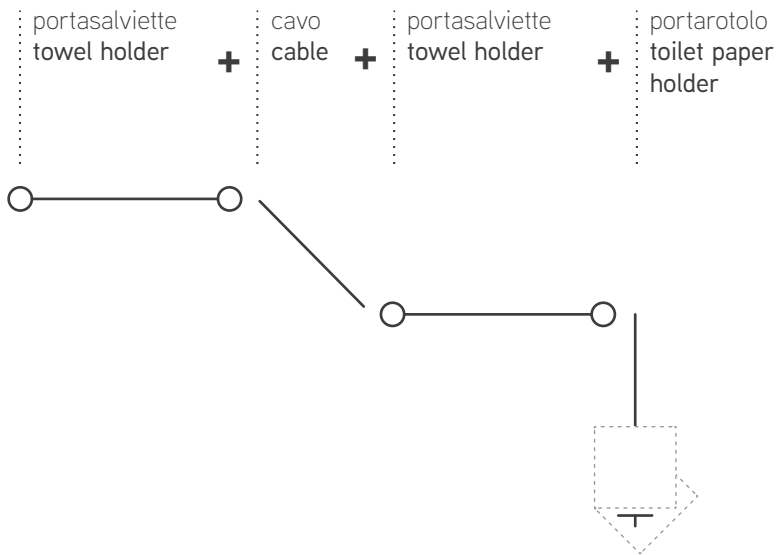







portasalviette
towel holder



mensola
shelf



portarivista
magazine
holder

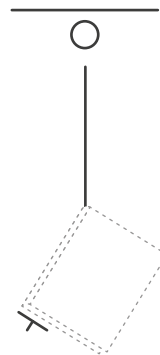

cover
cover



portarotolo
toilet paper
holder



La collezione Dot prevede piani di appoggio, fermo portarotolo, ulteriore metraggio di cavo e cilindri aggiuntivi.

.....

The collection DOT provides shelves, toilet paper holders, additional meters of steel rope and additional cylindrical covers.



Biblioteca Adelphi 16

Wassily Kandinsky

PUNTO LINEA SUPERFICIE









D O T

DOT

MIX AND MATCH

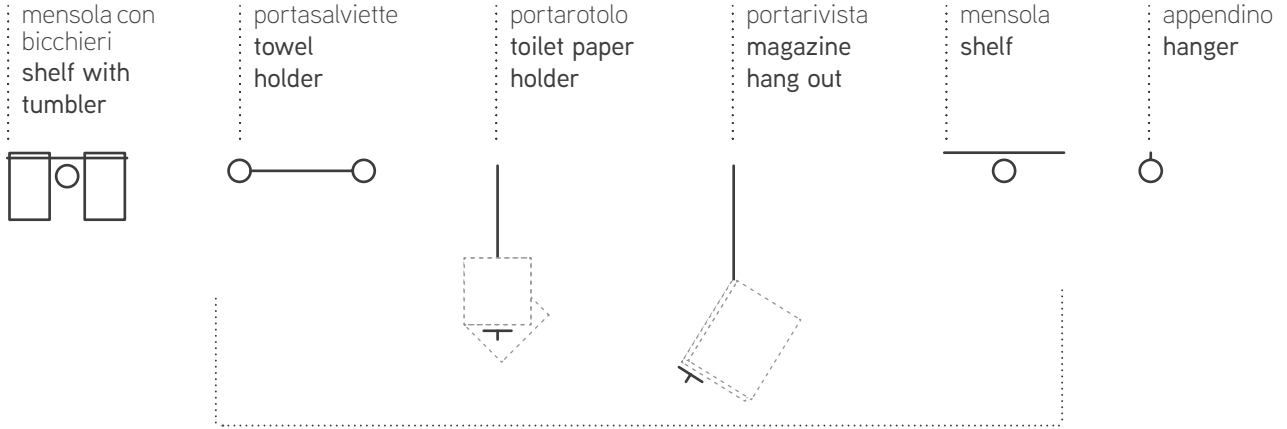

ELEMENTI ABBINABILI MATCHING ITEMS

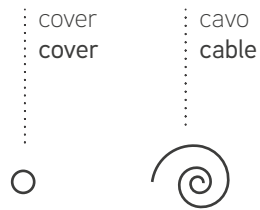

CONFIGURAZIONI PERSONALIZZATE MATCHING ITEMS

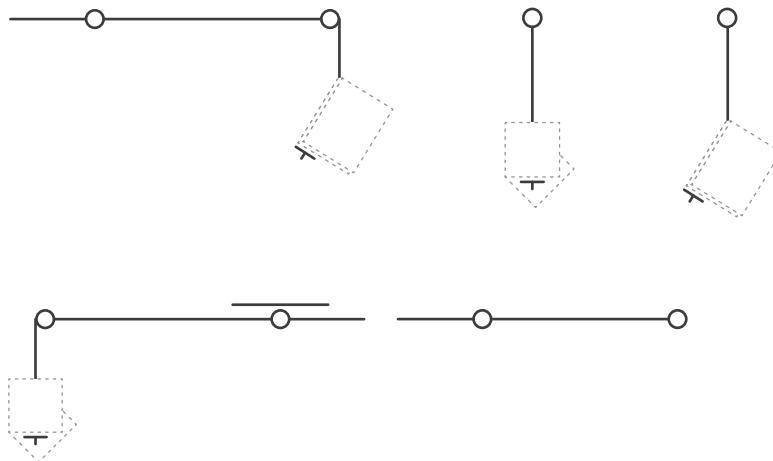

DOT

COVER E CAVI COVERS AND CABLES

DIMENSIONI mm
DIMENSIONS mm

cover
cover

∅ 38
L 79

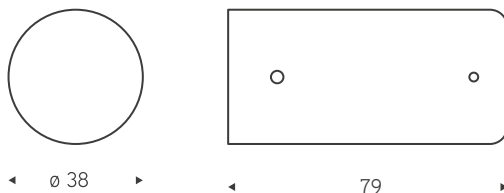

morsetto
clamp

∅ 10
L 12

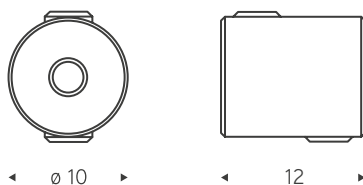

cavo
cable

∅ 1,5
L 600 - 1100

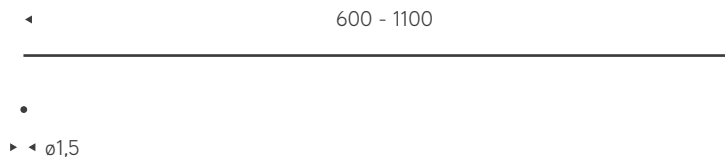

VARIANTI E DETTAGLI
VERSIONS AND DETAILS



MATERIALI

cover e morsetto: ottone
cavo: acciaio INOX
elementi elastici: NBR

FINITURE

cover: nero opaco, bianco opaco, cromo, nichel spazzolato

MATERIALS

cover and clamp: brass
cable: inox stainless steel
o-ring: NBR

FINISHES

cover: opaque black, opaque white, chrome, brushed nickel

DOT

.....

APPENDINO E PORTASALVIETTE HANGER AND TOWEL HOLDER

DIMENSIONI mm
DIMENSIONS mm

appendino hanger

∅ 38
L 79
H 50

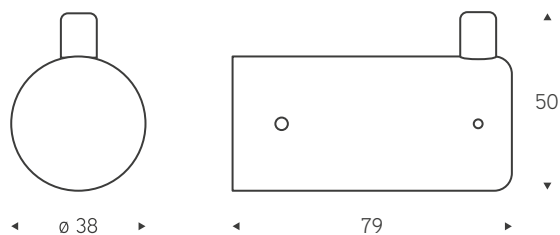

portasalvetta towel holder

∅ 38
L 79
H max. 1000

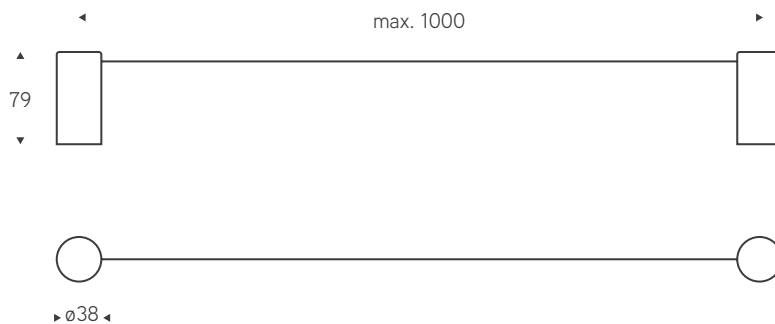

.....

VARIANTI E DETTAGLI VERSIONS AND DETAILS



MATERIALI	cover e morsetto: ottone elementi elastici: NBR
FINITURE	cover: nero opaco, bianco opaco, cromo, nichel spazzolato
MATERIALS	cover and clamp: brass o-ring: NBR
FINISHES	cover: opaque black, opaque white, chrome, brushed nickel

DOT

MENSOLE SHELVES

DIMENSIONI mm
DIMENSIONS mm

mensola shelf

L 175
H 42
P 79

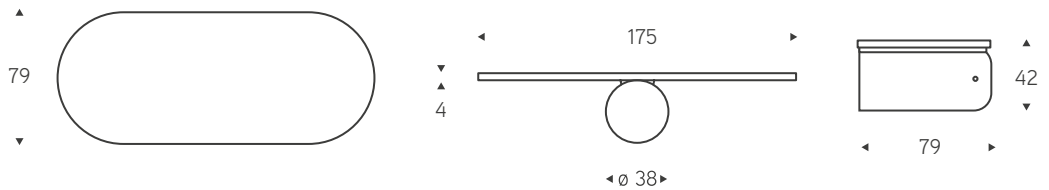

mensola con bicchieri shelf with tumbler

L 190
H 42
P 79

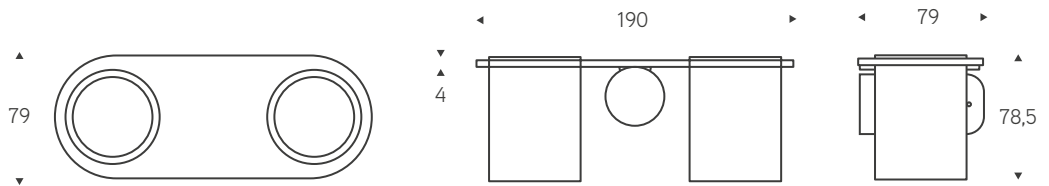

VARIANTI E DETTAGLI VERSIONS AND DETAILS



MATERIALI

cover, mensola: ottone
bicchieri: alluminio
elementi elastici: NBR

FINITURE

cover, mensola, bicchieri: nero opaco, bianco opaco,
cromo, nichel spazzolato

MATERIALS

cover, shelf: brass
tumblers: aluminium
elastic elements: NBR

FINISHES

cover, shelf, tumblers: opaque black, opaque white, chrome,
brushed nickel

DOT

.....

PORTAROTOLO E PORTARIVISTA TOILET PAPER HOLDER AND MAGAZINE HOLDER

DIMENSIONI mm
DIMENSIONS mm

portarotolo
toilet paper holder

L 70
H 550 max.

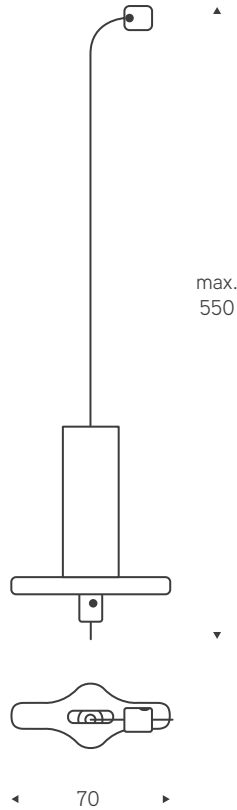

portariviste
magazine holder

∅ 38
H 550 max.

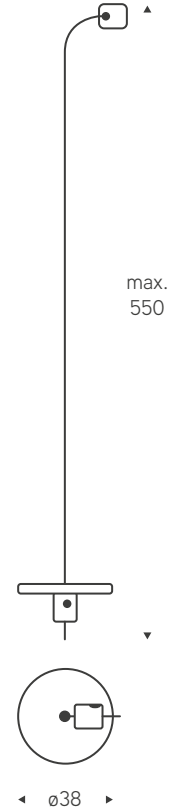

VARIANTI E DETTAGLI VERSIONS AND DETAILS



portarotolo



portariviste

MATERIALI

morsetto, fermo portarotolo: ottone
cilindro portarotolo: mdf
cavo: acciaio INOX

FINITURE

fermi: nero opaco, bianco opaco, cromo, nichel spazzolato
cilindro portarotolo: grigio polvere RAL7037

MATERIALS

clamp, paper toilet stopper: brass
roll: mdf
cable: inox stainless steel

FINISHES

stops: opaque black, opaque white, chrome plated,
brushed nickel plated
toilet paper roll: ash gray

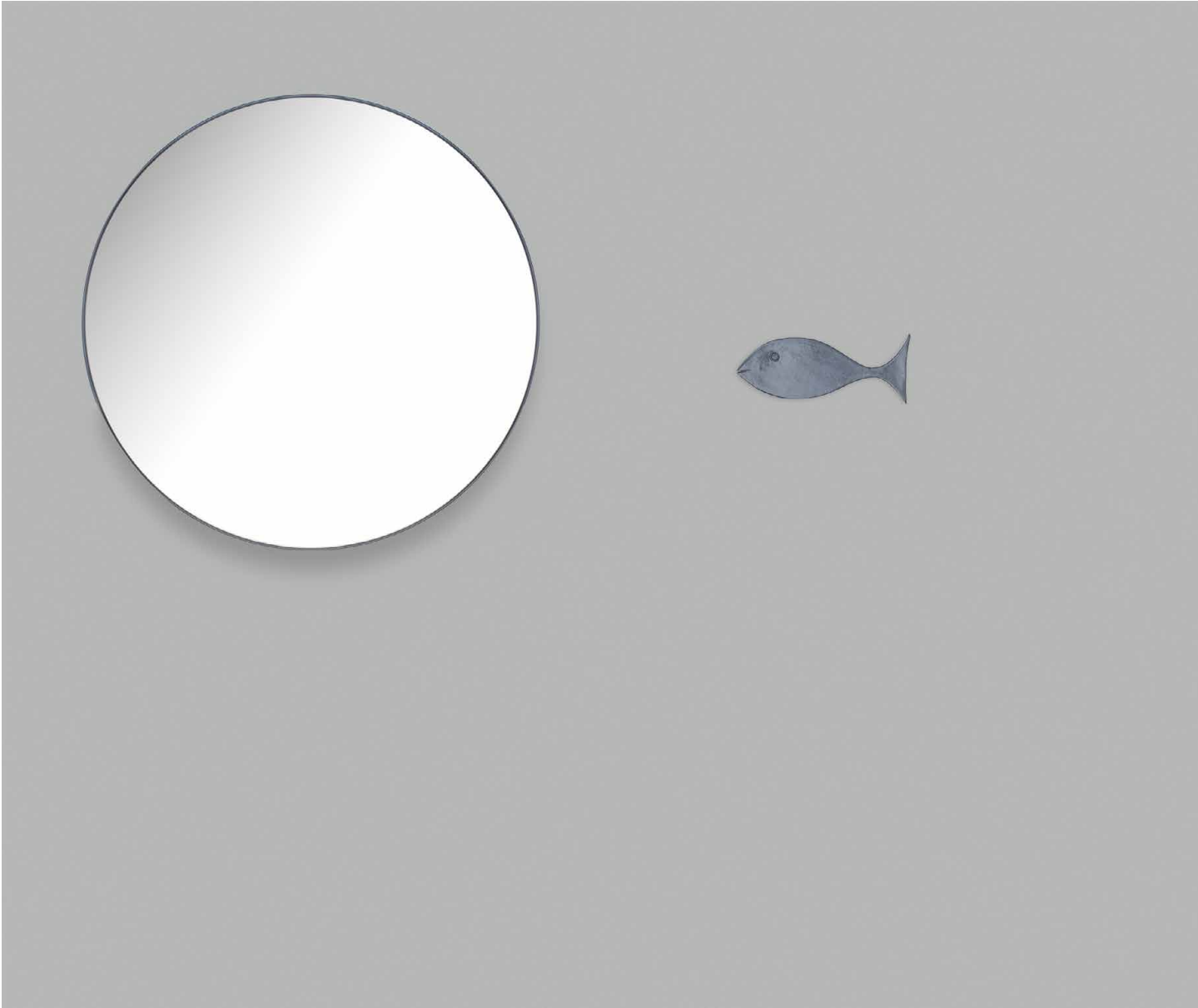

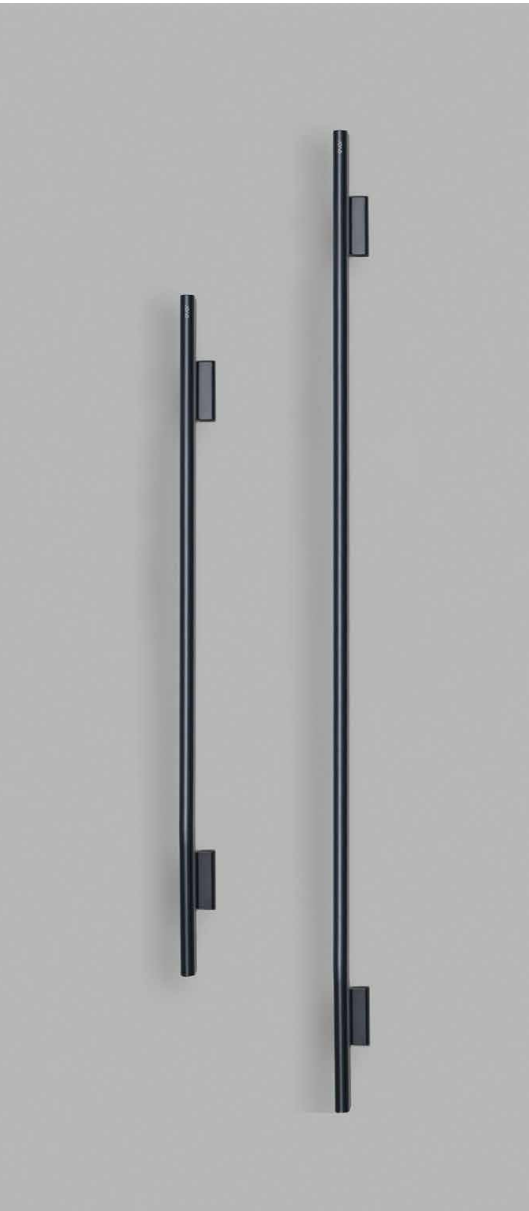

P R O P

.....

Design

Monica
Graffeo

.....

Una barra attrezzata portaoggetti che diventa un appiglio sicuro. Gli accessori hanno un design minimale che rendono la barra facile da inserire in ogni tipo di bagno.

Se posta a fianco del lavabo, la barra diventa una comoda estensione del piano di appoggio con vaschette, pianetti, dispenser e bicchiere. Lo specchio, applicabile alla barra, è progettato per avvicinarsi alla persona ed evitare sollecitazioni della schiena.

.....

An equipped bar for your accessories, that turns into a safety handhold.

Thanks to the accessories with a minimal design, it is possible to fit it everywhere. If you install it close to the washbasin, it is a convenient extension of the flat surface with trays, small shelves, dispensers and glasses. The mirror, that you can fix directly on the bar, has been designed to be easily turned and moved, in order to avoid strains on the back.

P R O P







PROP

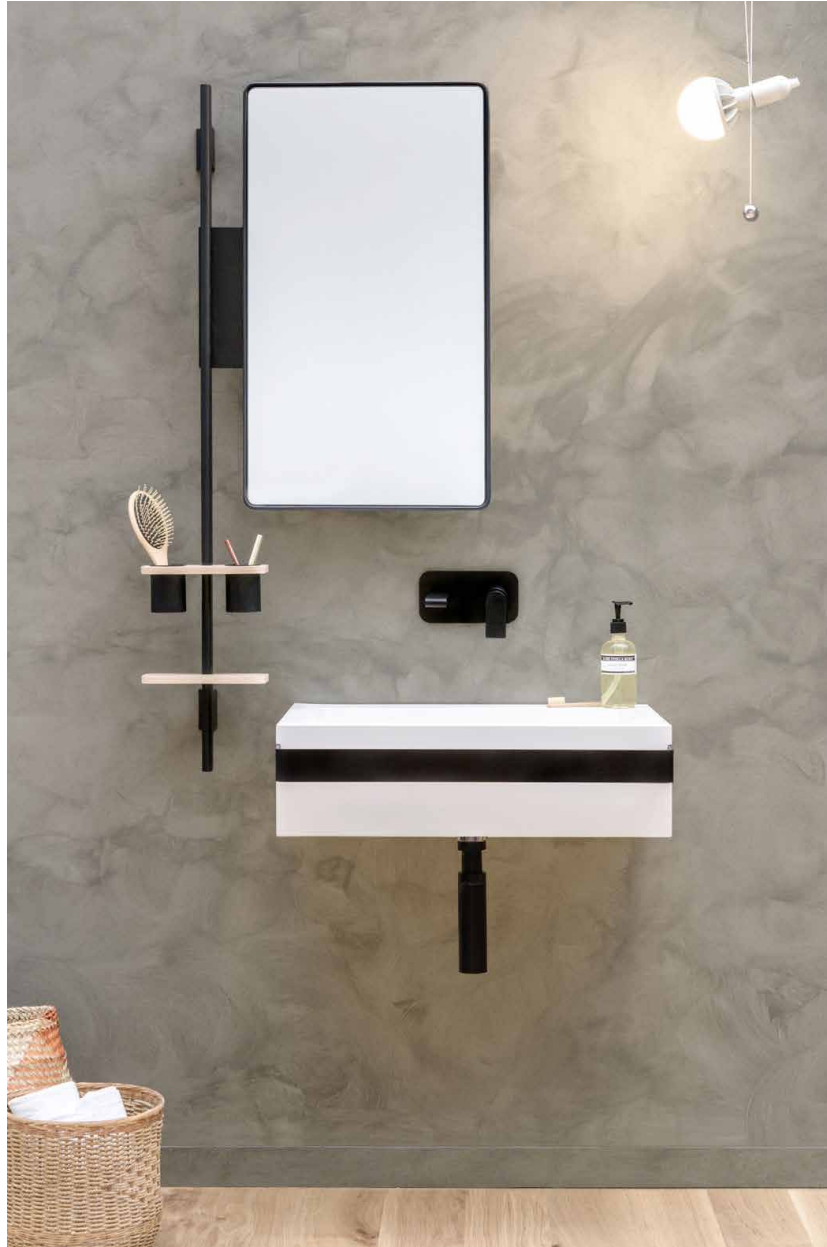

Lo specchio, circolare o rettangolare, da applicare alla barra può essere ruotato e spostato.

.....

The mirror, in round or rectangular shape, can be fixed to the bar and it can be easily turned and moved.





Le pratiche vaschette possono contenere diversi oggetti, permettendo alla barra di essere installata in qualsiasi parte della casa dove è necessario un sostegno ed un punto dove poter appoggiare piccoli oggetti della vita quotidiana.

.....

The practical bowls can contain different objects, allowing the bar to be installed everywhere in the house where support is needed and where small objects of everyday life can be placed.

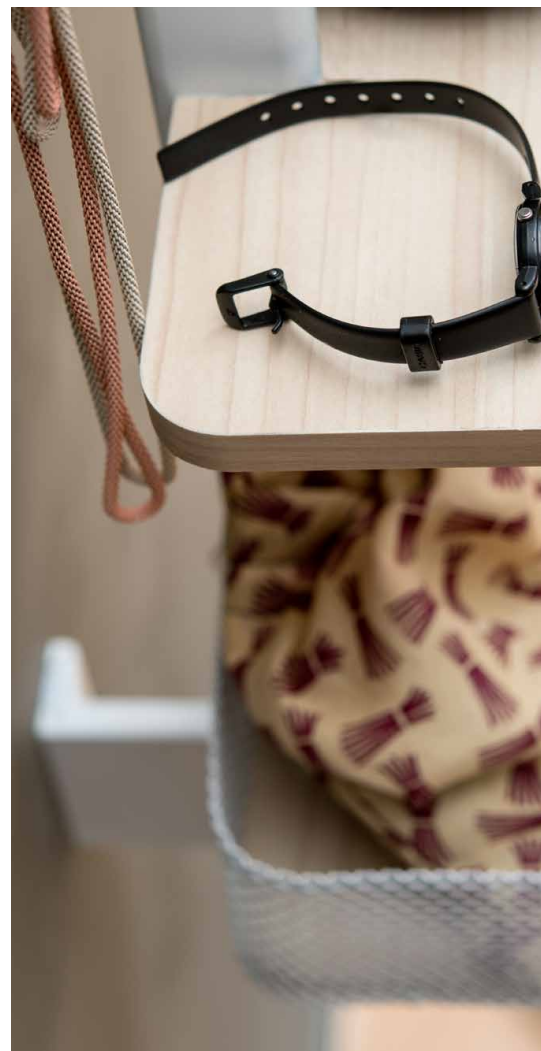

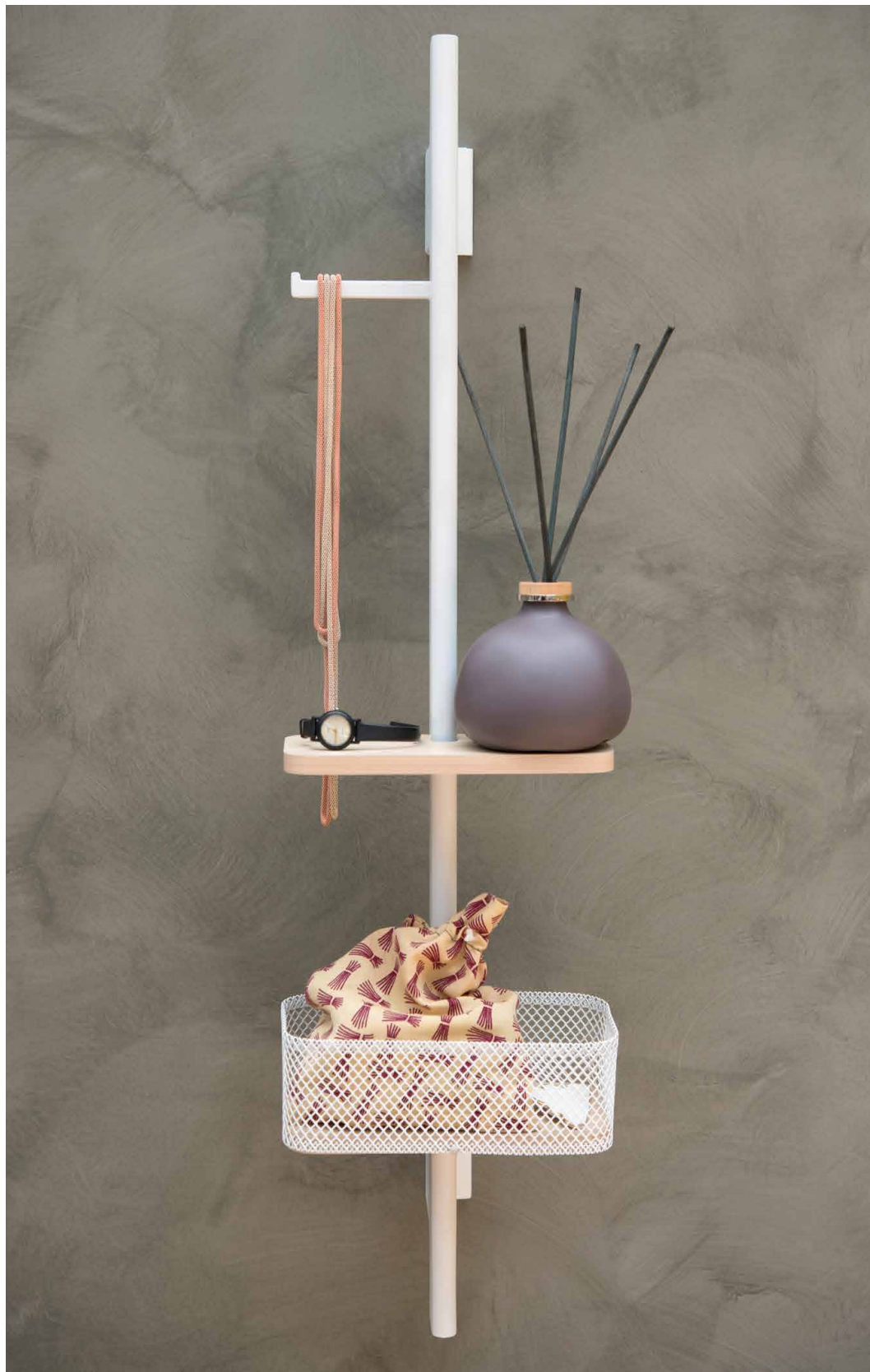

PROP

BARRA BAR

DIMENSIONI mm
DIMENSIONS mm

barra
bar

H 840-1140

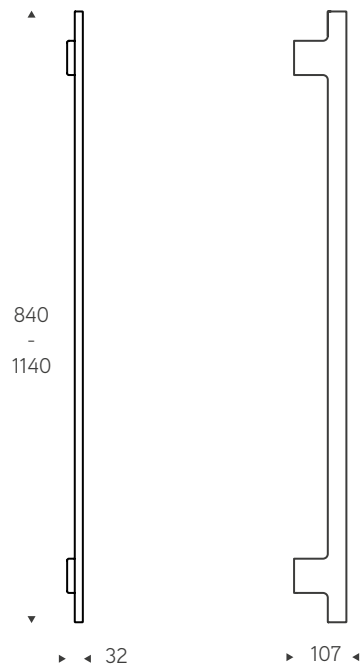

VARIANTI E DETTAGLI
VERSIONS AND DETAILS



MATERIALI	alluminio estruso
PORTATA	120 kg
COLORI	bianco, anodizzata, nero
MATERIALS	extruded aluminium
LOAD	120 kg
COLOURS	white, anodized, black

PROP

SPECCHI MIRRORS

DIMENSIONI mm
DIMENSIONS mm

specchio rotondo
rounded mirror

∅ 640
P 10

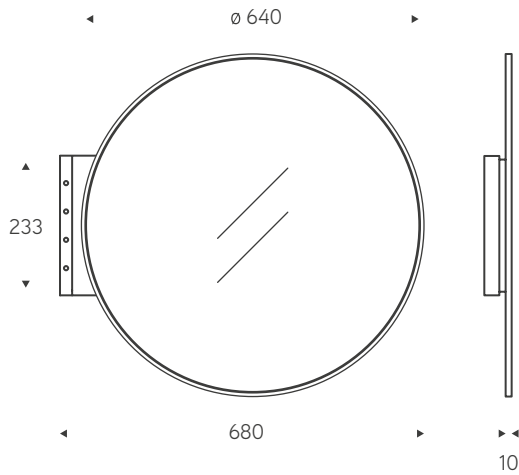

specchio rettangolare
rectangular mirror

L 389
H 699
P 10

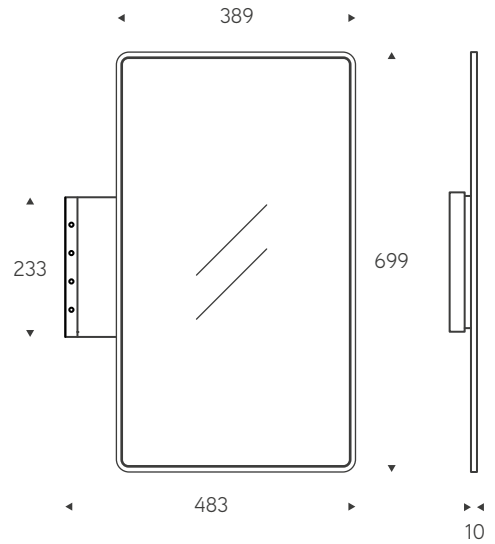

VARIANTI E DETTAGLI
VERSIONS AND DETAILS

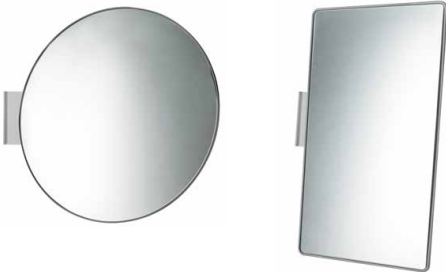

MATERIALI

COLORI

MATERIALS

COLOURS

vetro di sicurezza, legno naturale verniciato

fondo: bianco, grigio, nero

safety glass, natural painted wood

background: white, grey, black

PROP

ACCESSORI ACCESSORIES

DIMENSIONI mm
DIMENSIONS mm

appendiabiti
coat hanger

L 105
H 60

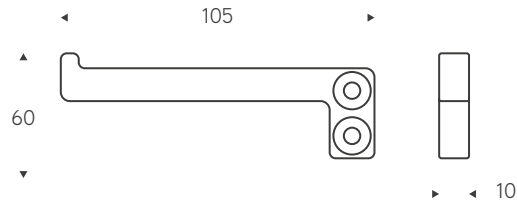

mensola con contenitore
shelf with meshed bowl

L 205
H 55
P 105

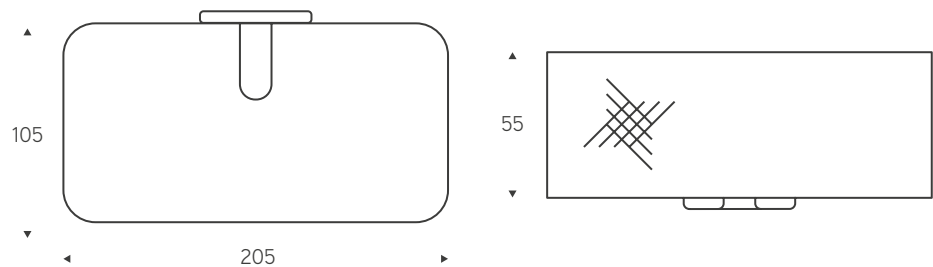

VARIANTI E DETTAGLI
VERSIONS AND DETAILS



MATERIALI

basetta: massello di frassino o stratificato
rete: acciaio inox
appendino: alluminio

COLORI

basetta: bianco, grigio, nero, frassino
rete: bianco, grigio, nero
appendino: bianco, anodizzato, nero

MATERIALS

base: natural solid ash or laminated
mesh: stainless steel
coat hanger: aluminum

COLOURS

base: white, grey, black, natural ash
mesh: white, grey, black
coat hanger: white, grey, black

note tecniche **technical details**

P R O P

ACCESSORI ACCESSORIES

DIMENSIONI mm
DIMENSIONS mm

mensola shelf

L 205
H 12
P 105

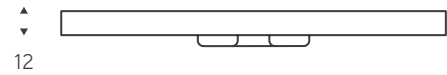
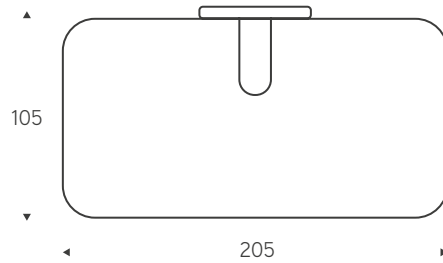

mensola con portabicchieri shelf with aluminium glasses

L 205
H 78,5
P 105

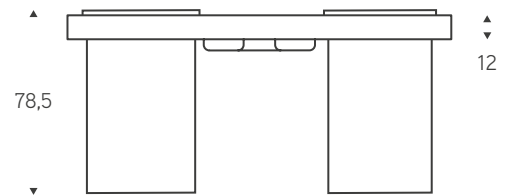
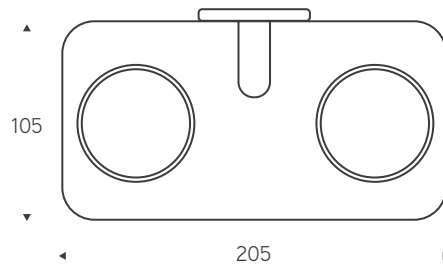

VARIANTI E DETTAGLI VERSIONS AND DETAILS



MATERIALI

basetta: massello di frassino o stratificato
bicchiere: alluminio verniciato

COLORI

basetta: bianco, grigio, nero, frassino
bicchiere: bianco opaco, grigio porpora opaco, anodizzato, nero opaco

MATERIALS

base: natural solid ash or laminated
tumbler: painted aluminium

COLOURS

base: white, grey, black, natural ash
tumbler: opaque white, opaque purple grey, anodized, opaque black

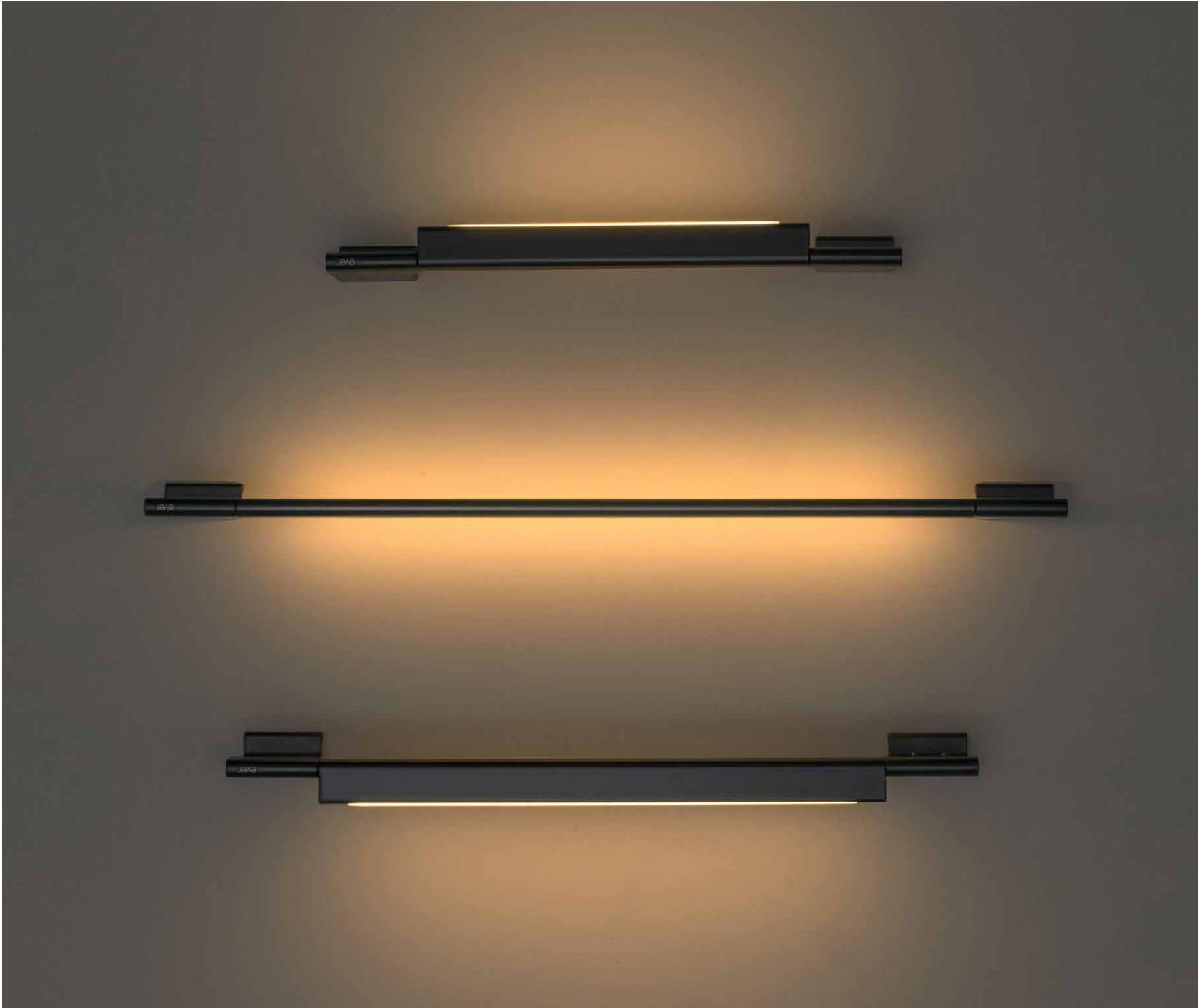

barra luminosa **led light bar**



S H I N E

.....

Design

Monica
Graffeo

.....

Una maniglia, un solido appoggio ma anche una luce ausiliare, per la notte o per creare una calda atmosfera che fa da guida nella sala da bagno. La barra luminosa a led è orientabile in diverse posizioni e proietta quindi la luce verso il basso, l'alto o la parete. Si può installare sia in posizione verticale sia orizzontale.

.....

A handle, a strong support but also an auxiliary light for the night or to create a warm atmosphere that acts as a guide in the bathroom. The LED light bar is adjustable in different positions, projecting the light downwards, upwards or toward the wall. It can be both vertically and horizontally installed.

S H I N E

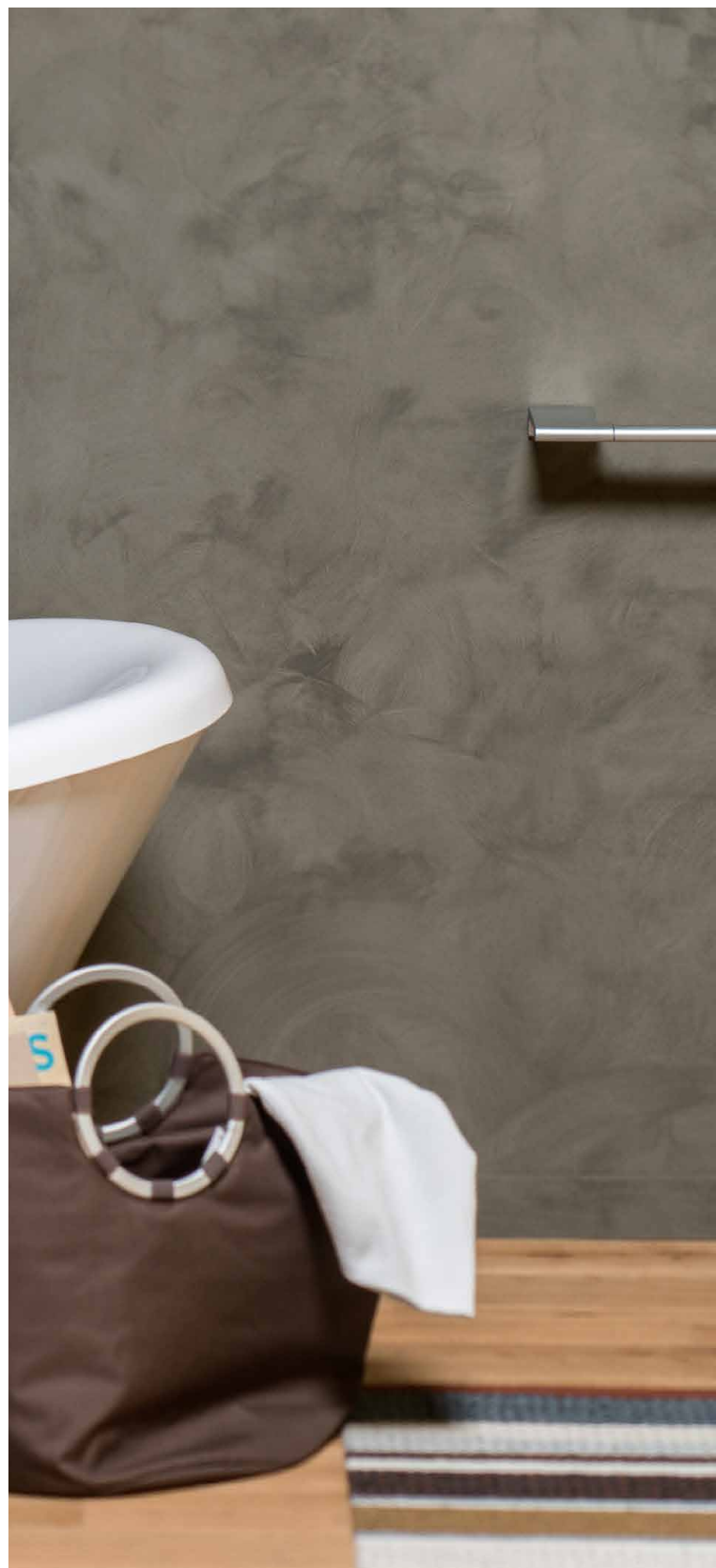

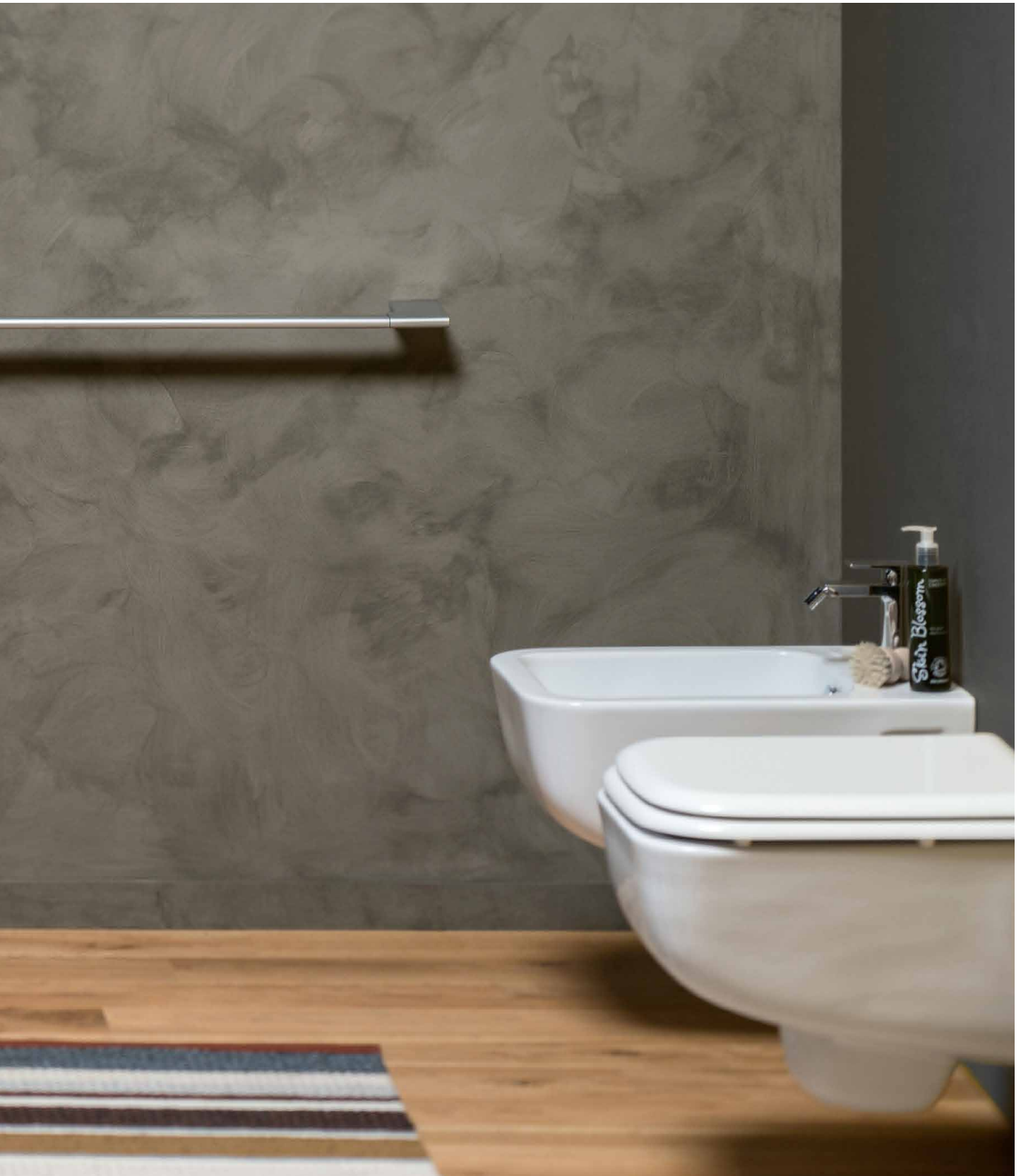

Disponibile anche in versione installabile
sotto la doccia (non orientabile).

.....

Also available for installation in the
shower (not adjustable).



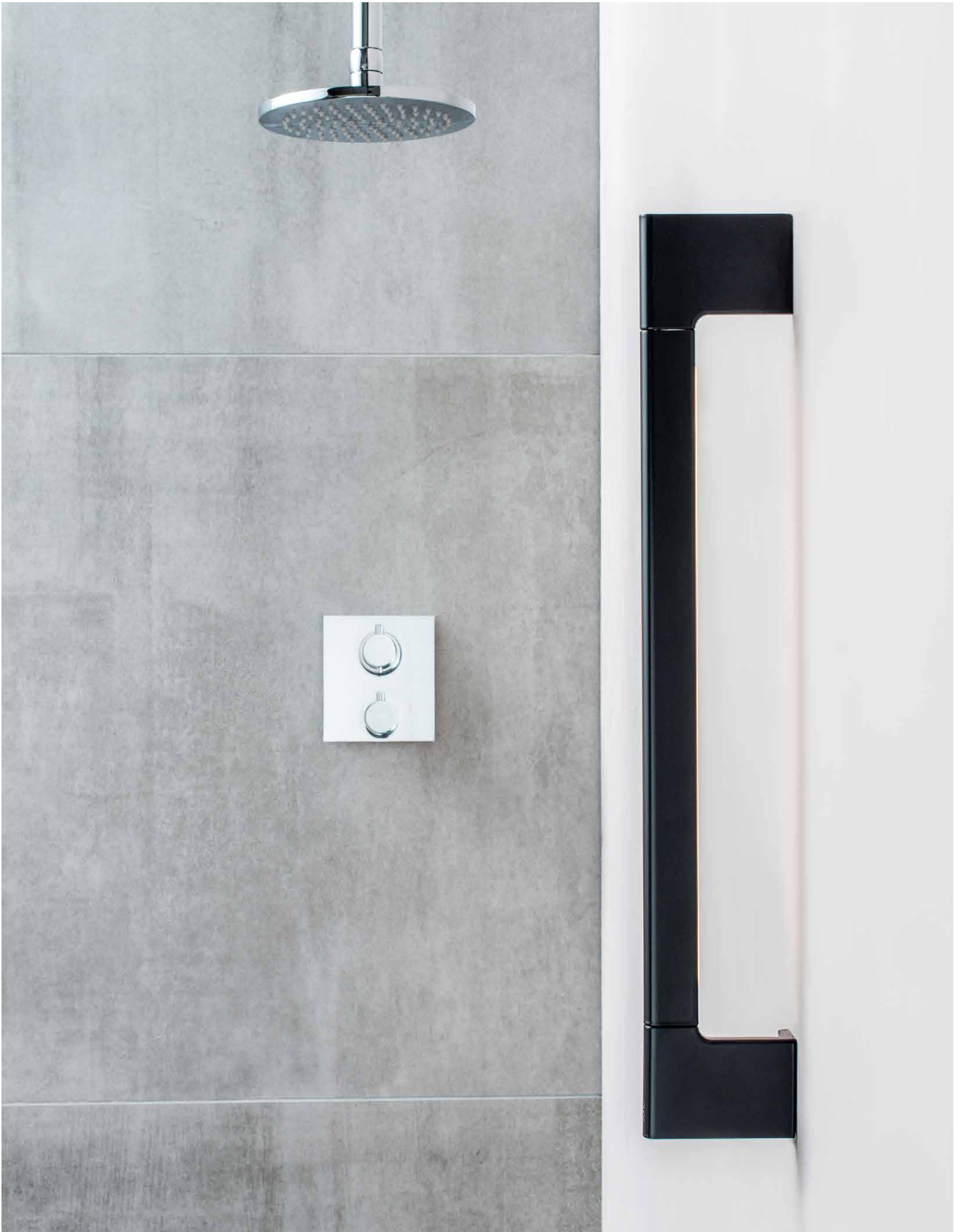

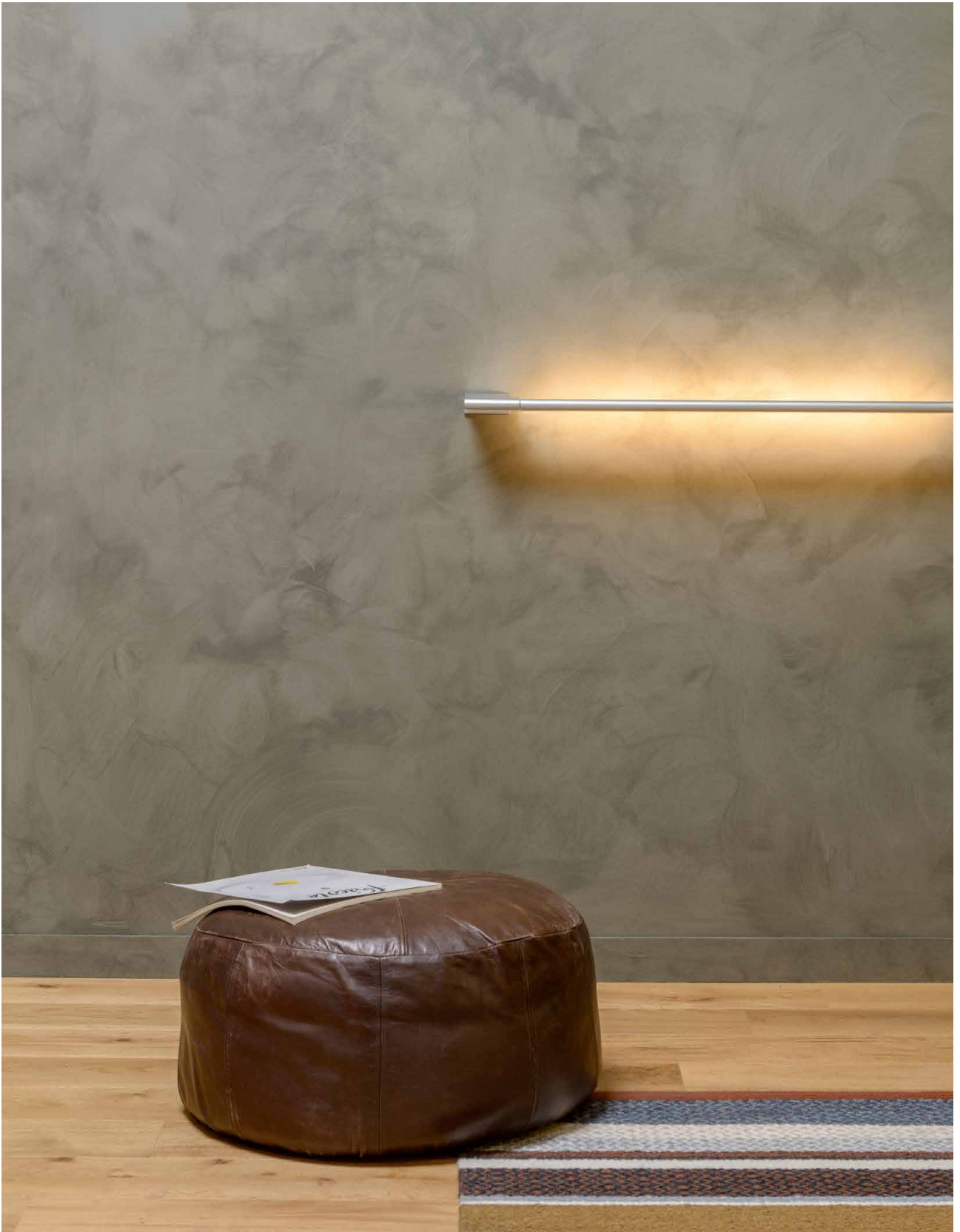

SHINE

La rotazione della barra è di 360°, il fascio di luce è quindi direzionabile verso la posizione preferita. La funzionalità di sostegno viene mantenuta e garantita in tutte le posizioni attraverso un efficace sistema di bloccaggio. La dispersione del calore consente alla barra di non surriscaldarsi anche in lunghi periodi di accensione.

.....

The LED bar is turnable through a secure 360° rotation, thus allowing to direct the light in the preferred direction. The support functionality, is maintained and guaranteed in all positions through an effective locking system of the light bar. The dispersion of heat allows the bar not to overheat even in long periods of lighting.





SHINE

SHINE

BARRA LUMINOSA LED LIGHT BAR

DIMENSIONI mm
DIMENSIONS mm

barra
bar

L 500 - 650 - 800
H 32
P 107

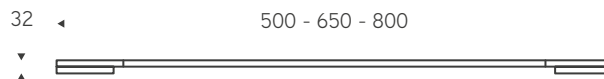

VARIANTI E DETTAGLI
VERSIONS AND DETAILS



MATERIALI alluminio estruso
PORTATA 120 kg
FINITURE bianco, anodizzata, nero
VERSIONI larghezza 500mm (5w), 650mm (7w), 800mm (9w)
LED 24 vdc, 3000 lm

MATERIALS extruded aluminium
LOAD 120 kg
FINISHES white, anodized, black
VERSIONS width 500mm (5w), 650mm (7w), 800mm (9w)
LED 24 vdc, 3000 lm

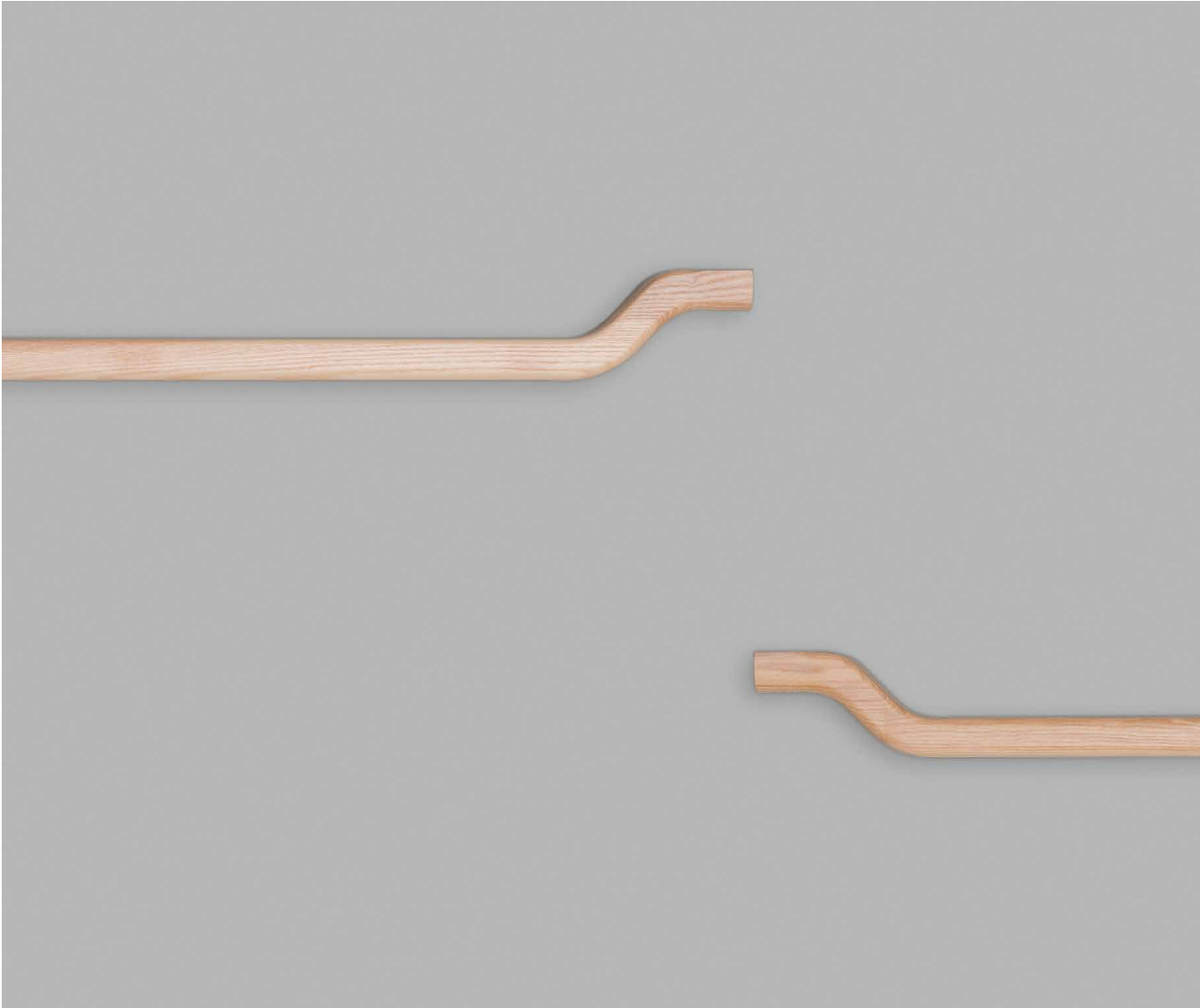

portasciugamani in legno **wood towel holders**



F E E L

.....

Design

Monica
Graffeo

.....

Feel è una barra sagomata con funzione di porta asciugamani in legno di frassino naturale e massiccio, piacevole al tatto che sorprende per la comodità della presa e la sicurezza del sostegno che offre. Applicabile sia in posizione verticale, sia orizzontale.

.....

Feel is a shaped bar made of natural ash all-wood with towel holder function, a pleasant touch that surprises for comfort and safety that it offers. Installable both in vertical and horizontal position.

F E E L







FEEL



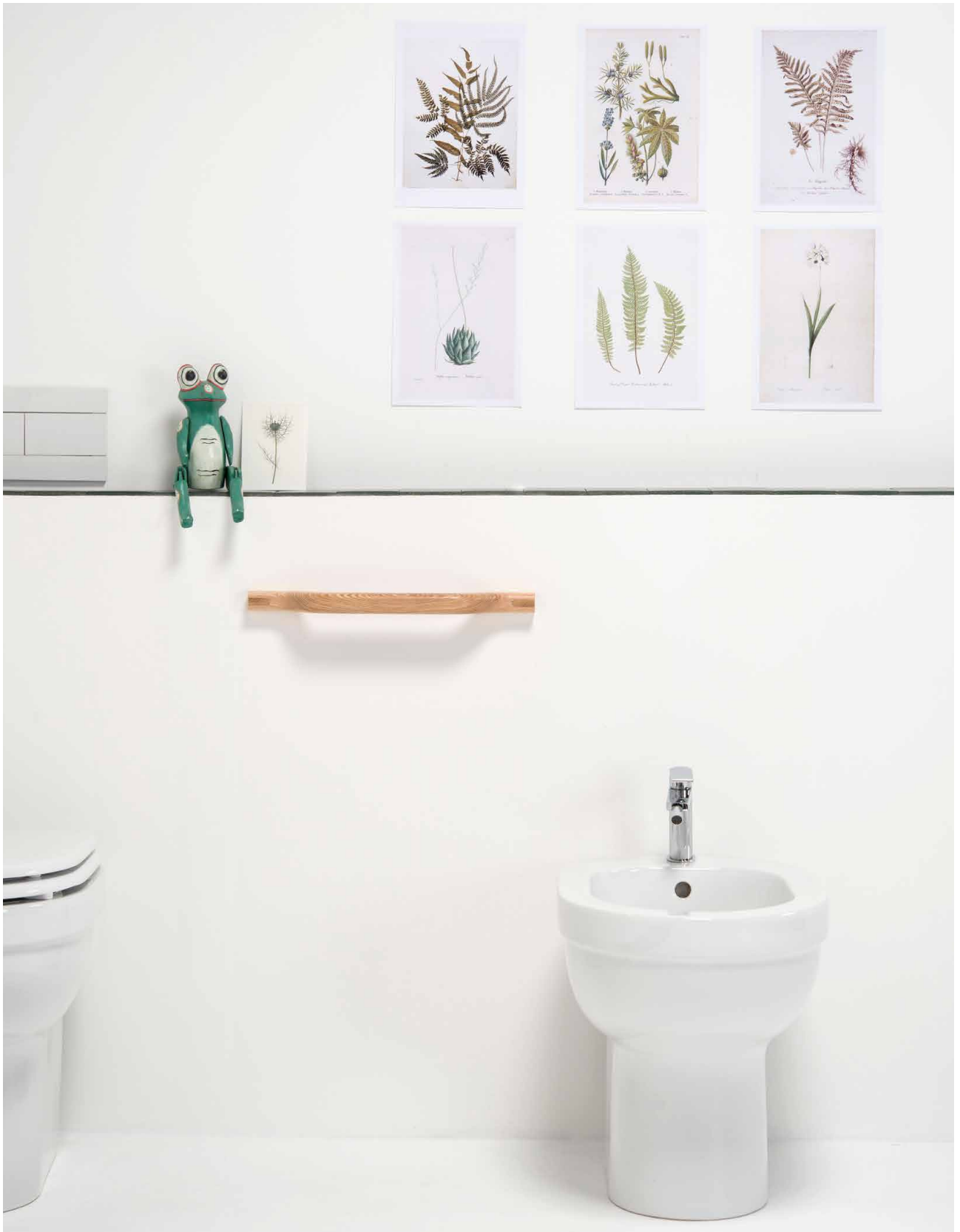

FEEL

FEEL

.....

PORTASCIUGAMANI TOWEL HOLDER

DIMENSIONI mm
DIMENSIONS mm

portasciugamani
towel holder

L 350 - 450
600 - 800

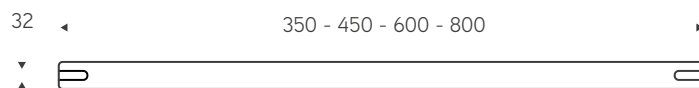

VARIANTI E DETTAGLI
VERSIONS AND DETAILS



MATERIALI	massello di frassino
PORTATA	120 kg
MATERIALS	natural solid ash
LOAD	120 kg



portasciugamani e barra ribaltabile **towel holder and folding bar**



S T Y L E

.....

Design

Thermomat

.....

La linea di portasciugamani di sicurezza della serie Style, offre tutta la capacità di tenuta di un tradizionale supporto a muro con un design assolutamente sofisticato. Diverse misure e tantissime finiture: soft che garantisce il miglior grip e una sensazione tattile morbida e vellutata, cromata, satinata o verniciata.

.....

The range of safety towel holders Style, combines the safety and solidity of a standard wall mounted support with a sophisticated design. Several sizes and many finishes are available: soft: in order to guarantee an excellent grip and a soft tactile sensation; chrome-plated, satin or painted.



STYLE





STYLE



Cambiare faccia ad un bagno: grazie ad un semplice gesto, svitando solo una vite, la barra può essere tolta e sostituita con un pratico piattino portasapone.

.....

Change the look of a bathroom: with a simple gesture, unscrewing only one screw, the folding bar can be removed and replaced with a practical soap dish



STYLE





STYLE



STYLE

PORTASCIUGAMANI DI SICUREZZA SAFETY TOWEL HOLDER

DIMENSIONI mm
DIMENSIONS mm

portasciugamani
towel holder

L 350 - 450
550 - 650
750
∅ 28

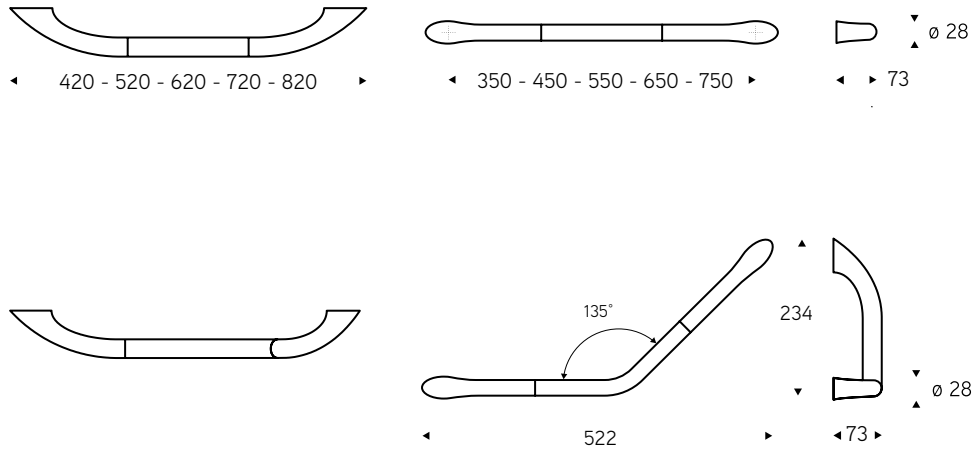

VARIANTI E DETTAGLI VERSIONS AND DETAILS



MATERIALI	ottone
PORTATA	150 kg
COLORI	di serie: bianco opaco nero opaco, antracite soft su richiesta: tutti i colori nella versione lucida o soft
FINITURE	di serie: cromo, cromo + soft su richiesta: satinato, oro, bronzo, rame
MATERIALS	brass
LOAD	150 kg
COLOURS	standard opaque white, opaque black, soft anthracite on request: every colour will be available for shiny and soft
FINISHES	standard chromed and chromed + soft anthracite on request: satin, gold, bronze, copper colour

STYLE

BARRA RIBALTABILE FOLDING BAR

DIMENSIONI mm
DIMENSIONS mm

barra
bar
L 607

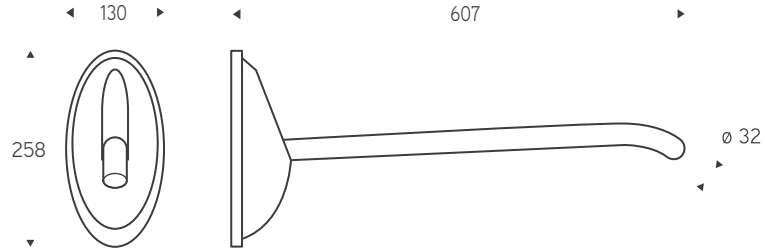

mensola
shelf
L 180
P 183

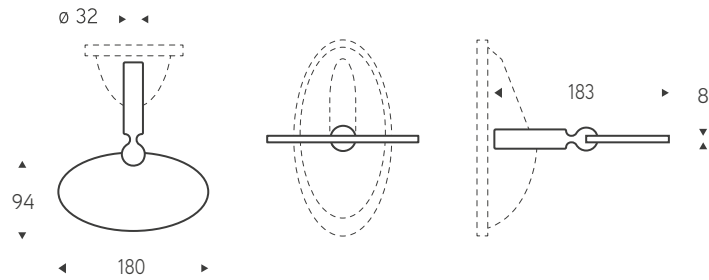

VARIANTI E DETTAGLI VERSIONS AND DETAILS



MATERIALI	acciaio, poliuretano mensola: vetro
PORTATA	150 kg
FINITURE	barra: bianco, bianco soft, antracite soft cover: bianco, nero
MATERIALS	steel and polyurethane shelf: glass
LOAD	150 kg
FINISHES	bar: white, soft white, soft anthracite cover: white, black

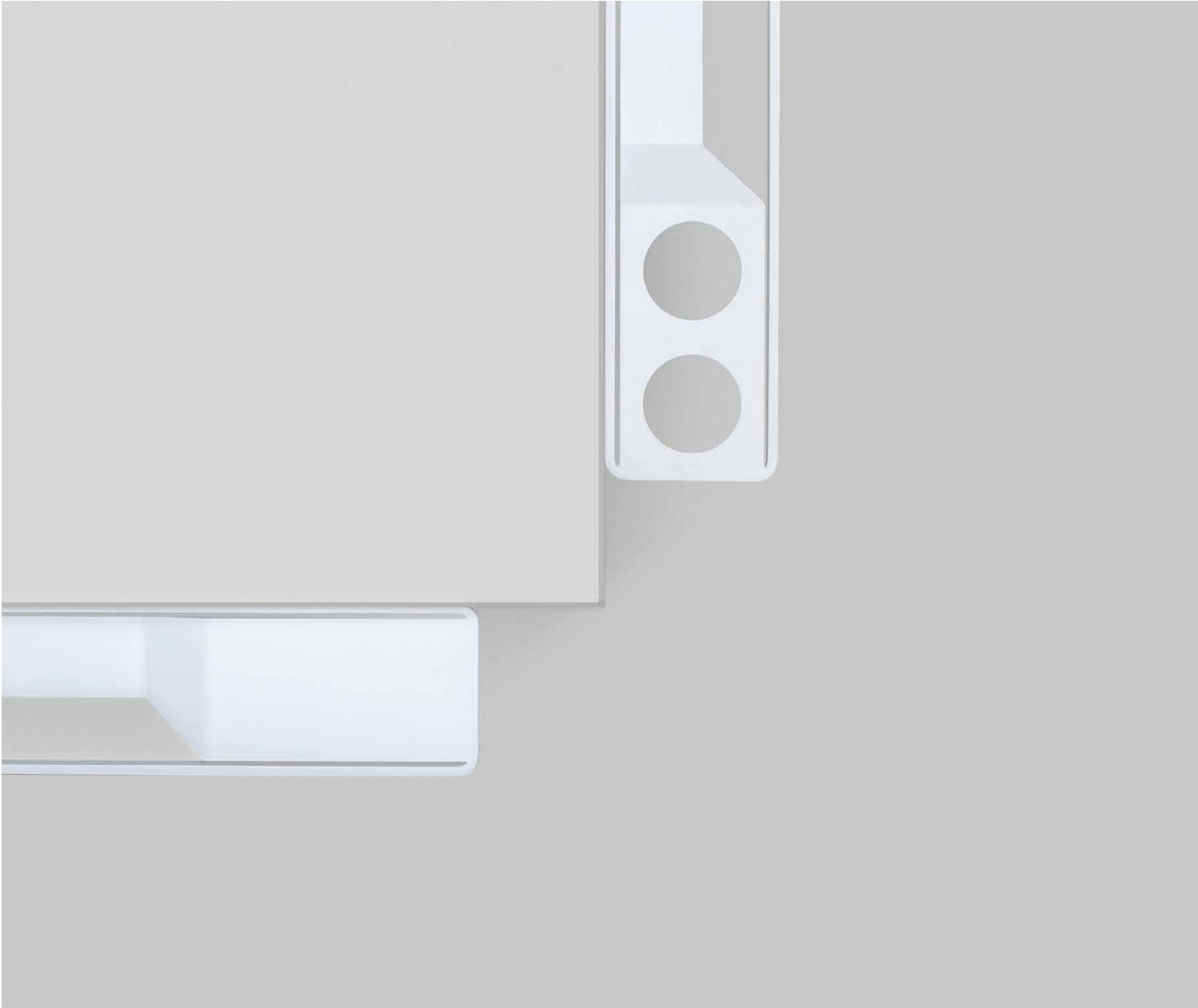

mensole **shelves**

B R U N T



.....

Design

Monica
Graffeo

.....

Una collezione di accessori dal disegno lineare ed essenziale con una funzionalità amplificata: non solo prese di appoggio, ma anche complementi d'arredo portasalviette, portaoggetti e svuotatasche.

.....

A collection of accessories featuring a linear and essential design with a wide functionality: not only supports, but also furnishing accessories, towel holders, shelves and pocket emptiers.

B R U N T







BRUNT

Una mensola portasciugamani, un valido sostegno, uno spazio per appoggiare gli oggetti, un porta dispenser ed un porta spazzolini. In un solo oggetto, diverse utili funzionalità.

.....

A towel-holder shelf, a valid support, a place to put the objects, a soap dispenser-holder and a toothbrush-holder. In only one object, several useful features.



Il portarotolo è componente essenziale della collezione: un discreto, ma sicuro supporto da bagno.

La barra verticale offre sicurezza e praticità nell'ambiente doccia.

.....

The toilet paper holder is an essential component of the collection: a discrete but safe support.

The vertical bar offers safety and comfort in the shower.

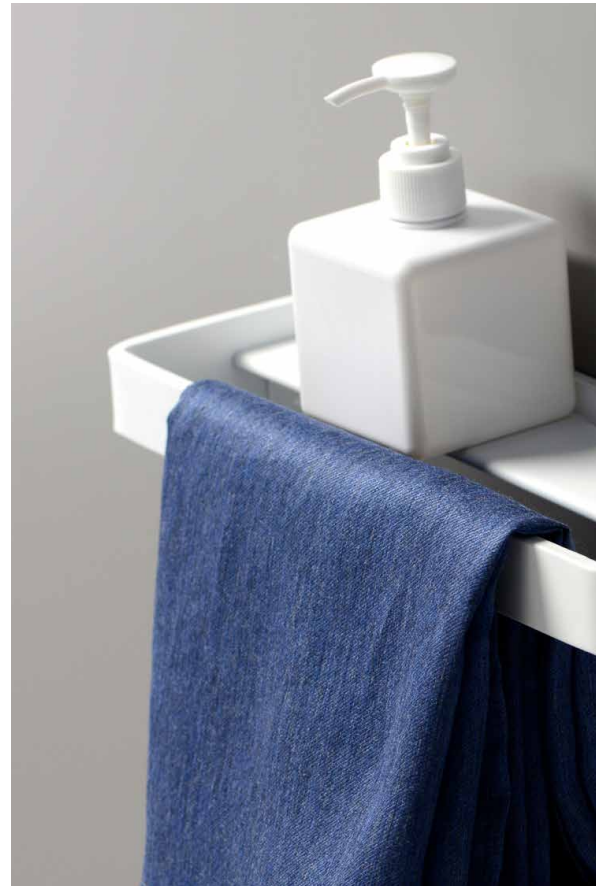





BRUNT



BRUNT

MENSOLE SHELVES

DIMENSIONI mm
DIMENSIONS mm

portarotolo toilet paper holder

L 140
H 46
P 145

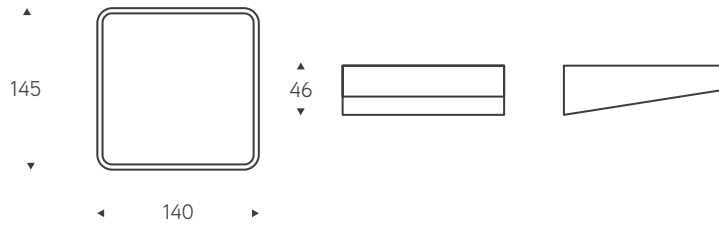

mensole shelves

L 200 - 300
450 - 600
P 105

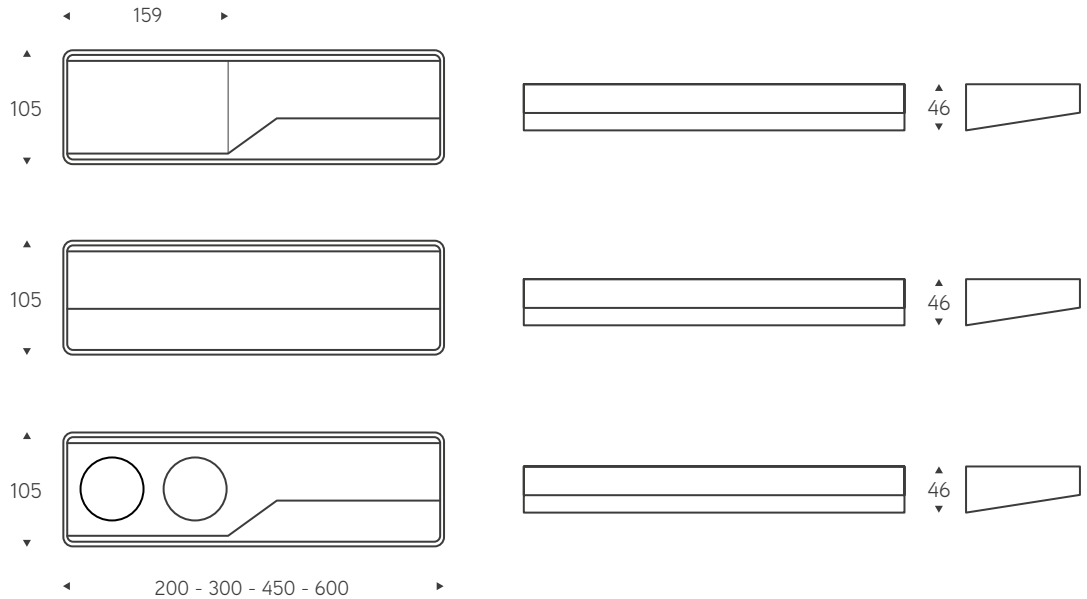

VARIANTI E DETTAGLI VERSIONS AND DETAILS



MATERIALI	acciaio
PORTATA	150 kg
FINITURE	bianco opaco, grigio porpora opaco, nero opaco
MATERIALS	steel
LOAD	150 kg
FINISHES	opaque white, opaque purple grey, opaque black

BRUNT

BARRA BAR

DIMENSIONI mm
DIMENSIONS mm

barra
bar

L 40
H 1000
P 100

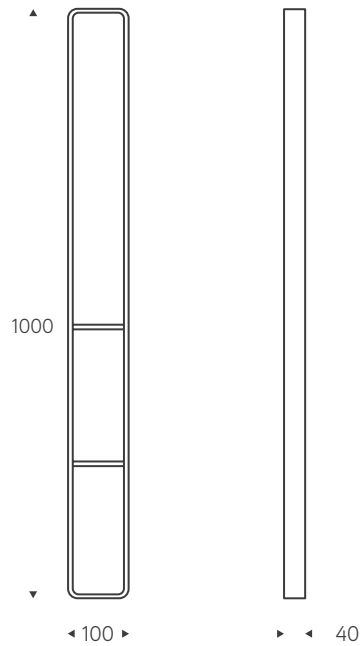

VARIANTI E DETTAGLI
VERSIONS AND DETAILS



MATERIALI	acciaio
PORTATA	150 kg
FINITURE	bianco opaco, grigio porpora opaco, nero opaco
MATERIALS	steel
LOAD	150 kg
FINISHES	opaque white, opaque purple grey, opaque black

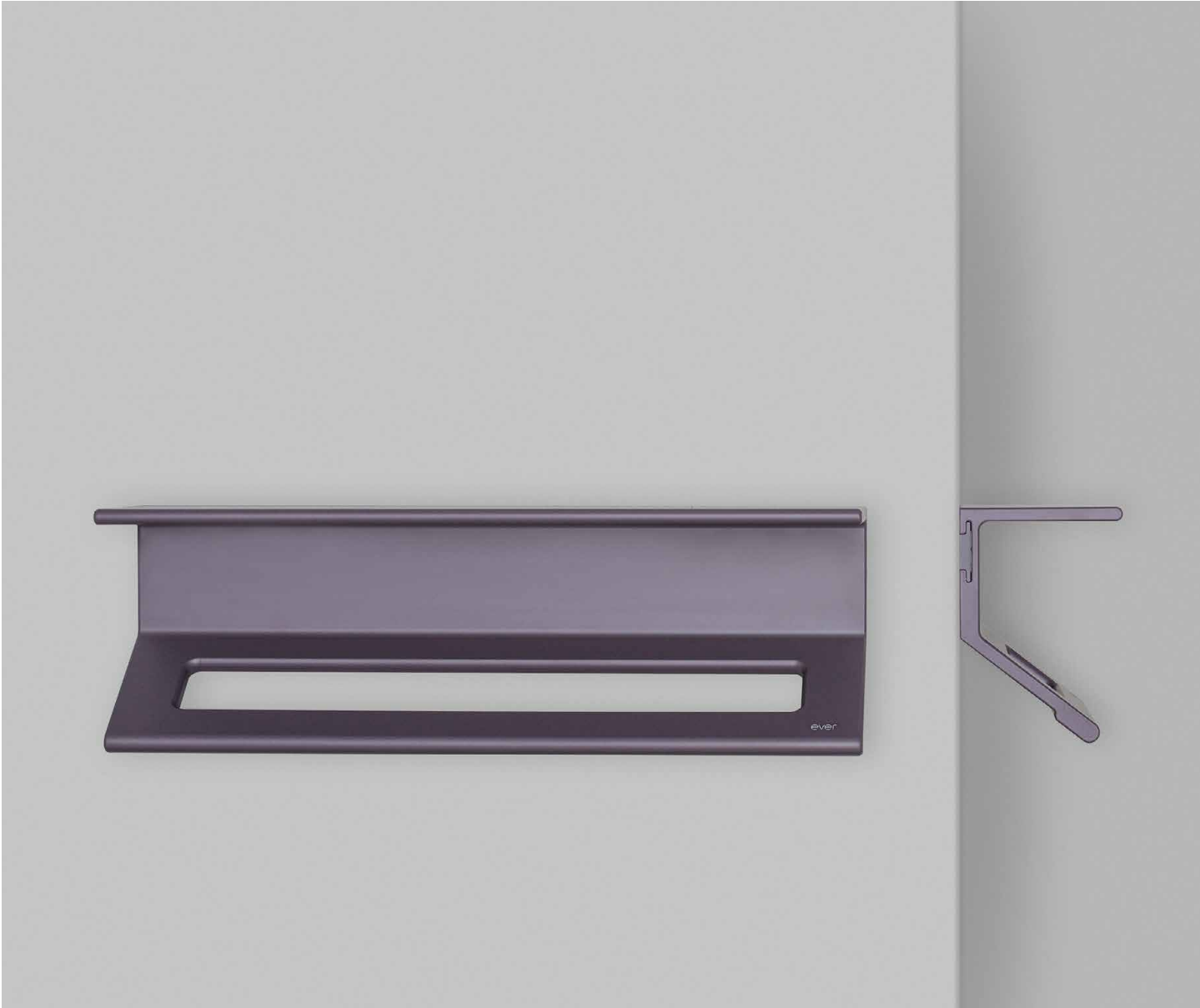

mensole **shelves**

L I S S O M



.....

Design

Monica
Graffeo

.....

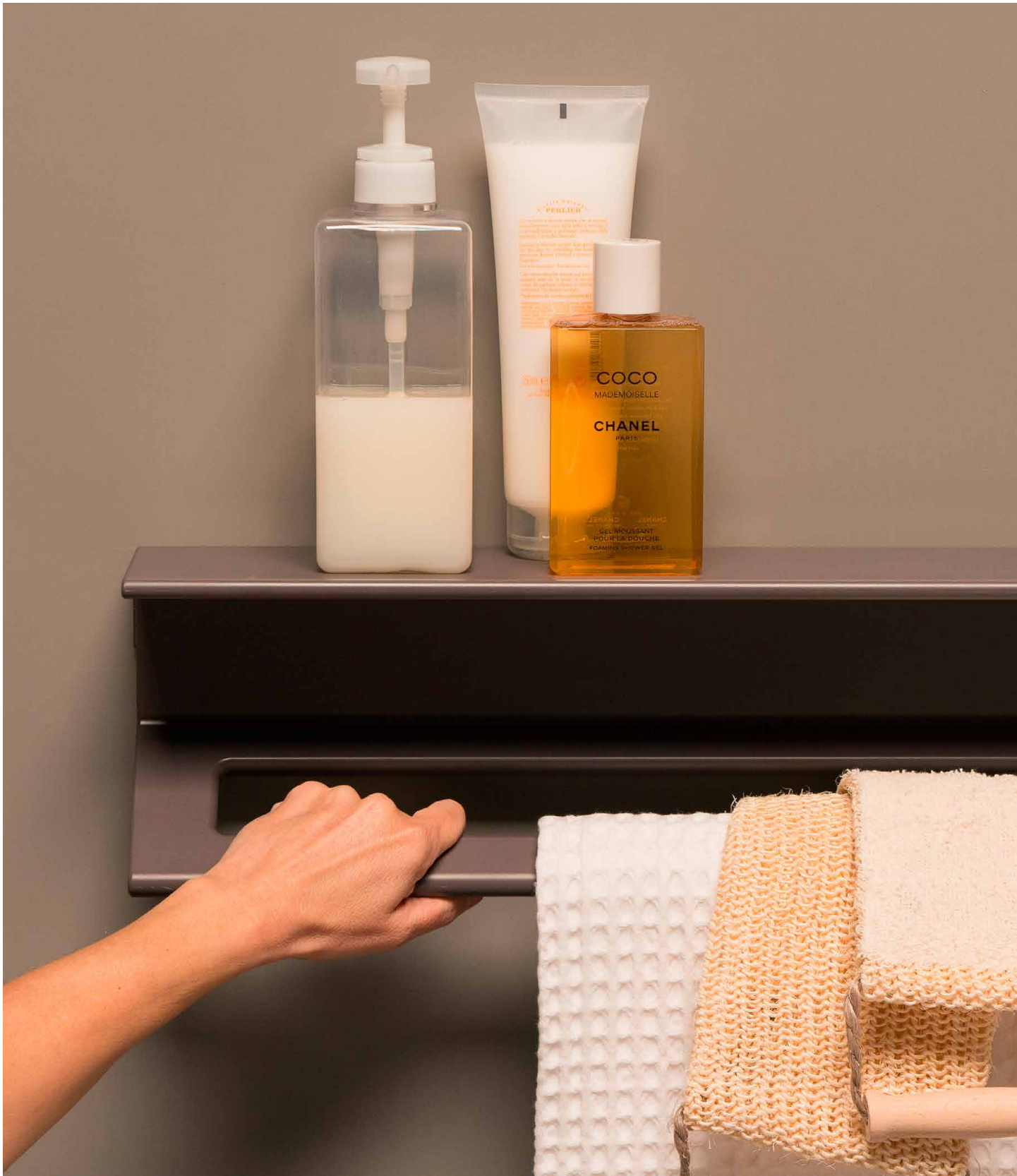

LISSOM



Mensole polifunzionali che diventano sostegno in caso di necessità e offrono nel contempo uno spazio da utilizzare come appoggio per flaconi, cosmetici, riviste o come svuotatasche.

.....

Multifunctional shelves that become support in case of need and at the same time offer a space to be used as a support for bottles, cosmetics, magazines or as a pocket emptier.



L I S S O M





L I S S O M





L I S S O M

L I S S O M

MENSOLE SHELVES

DIMENSIONI mm
DIMENSIONS mm

portarotolo toilet paper holder

L 200
P 100

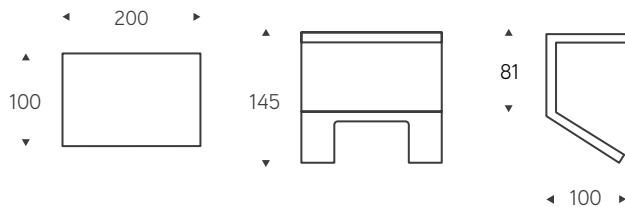

mensole shelves

L 200 - 300
450 - 600
H 145
P 100

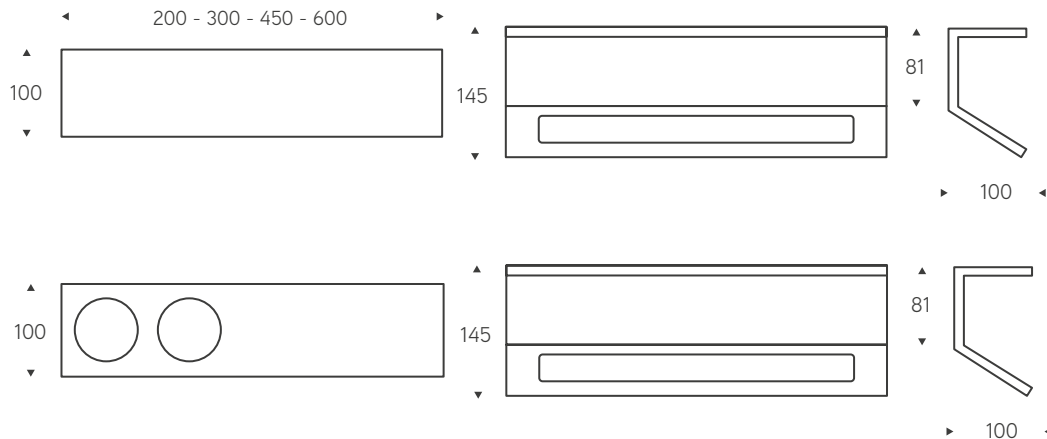

VARIANTI E DETTAGLI VERSIONS AND DETAILS



MATERIALI	alluminio trafilato
PORTATA	150 kg
FINITURE	bianco opaco, anodizzato, grigio porpora opaco, nero opaco
MATERIALS	drawn aluminium
LOAD	150 kg
FINISHES	opaque white, anodized, opaque purple grey, opaque black



GAMBOL



.....

Design

Monica
Graffeo

.....

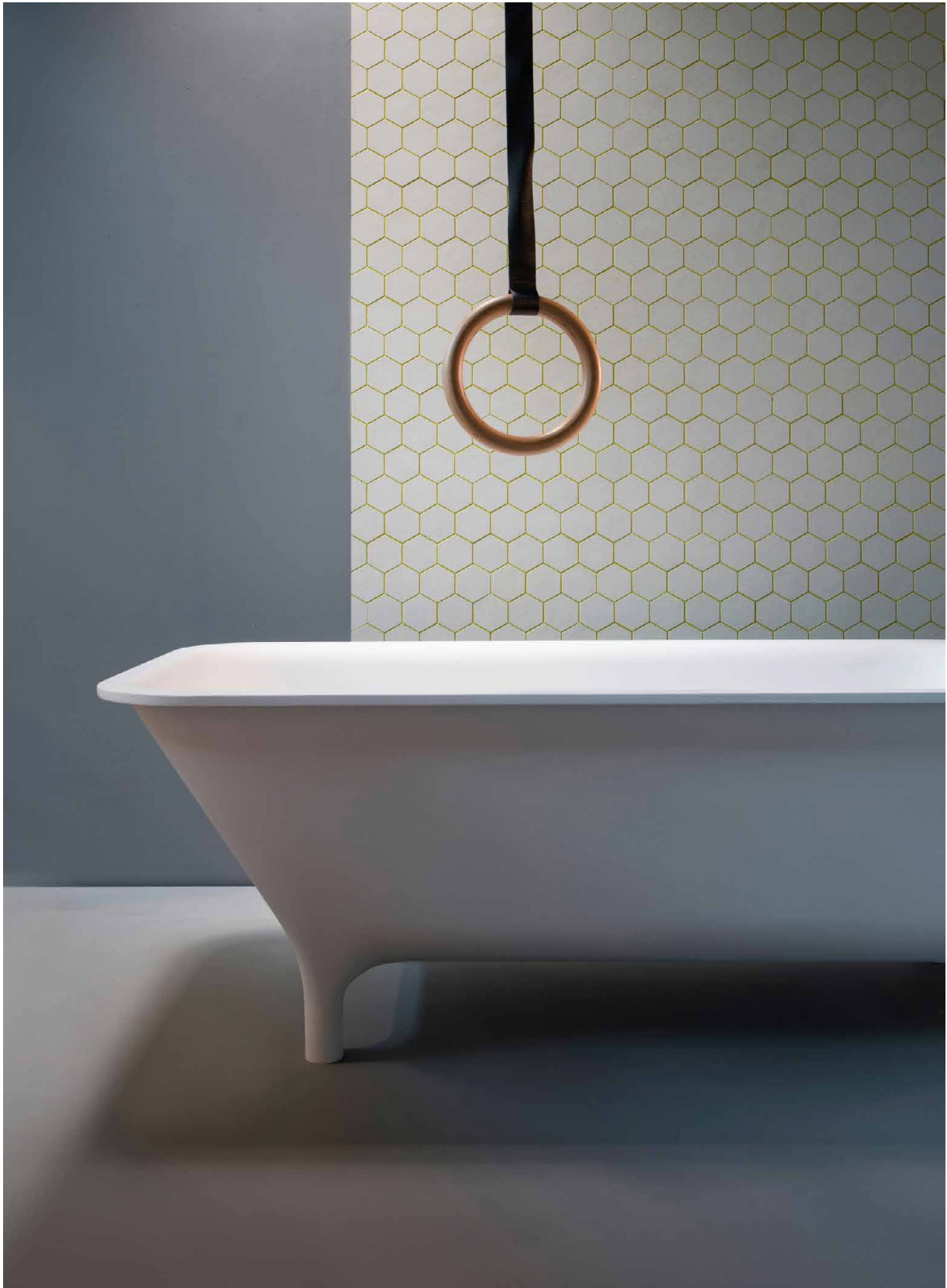

G A M B O L



Due attrezzi ginnici decontestualizzati e accolti nell'ambiente bagno come sostegni e supporti, ma anche come inusuali accessori portasalviette. Elementi empatici, associabili al corpo che vuole dare il meglio di sé, e naturali, grazie all'utilizzo del legno di faggio.

.....

Two exercisers decontextualized and welcomed in the bathroom as supports and even as unusual towel holders. Natural, thanks to the use of beechwood, and empathic elements, associated to the body that wants to give its best.



G A M B O L

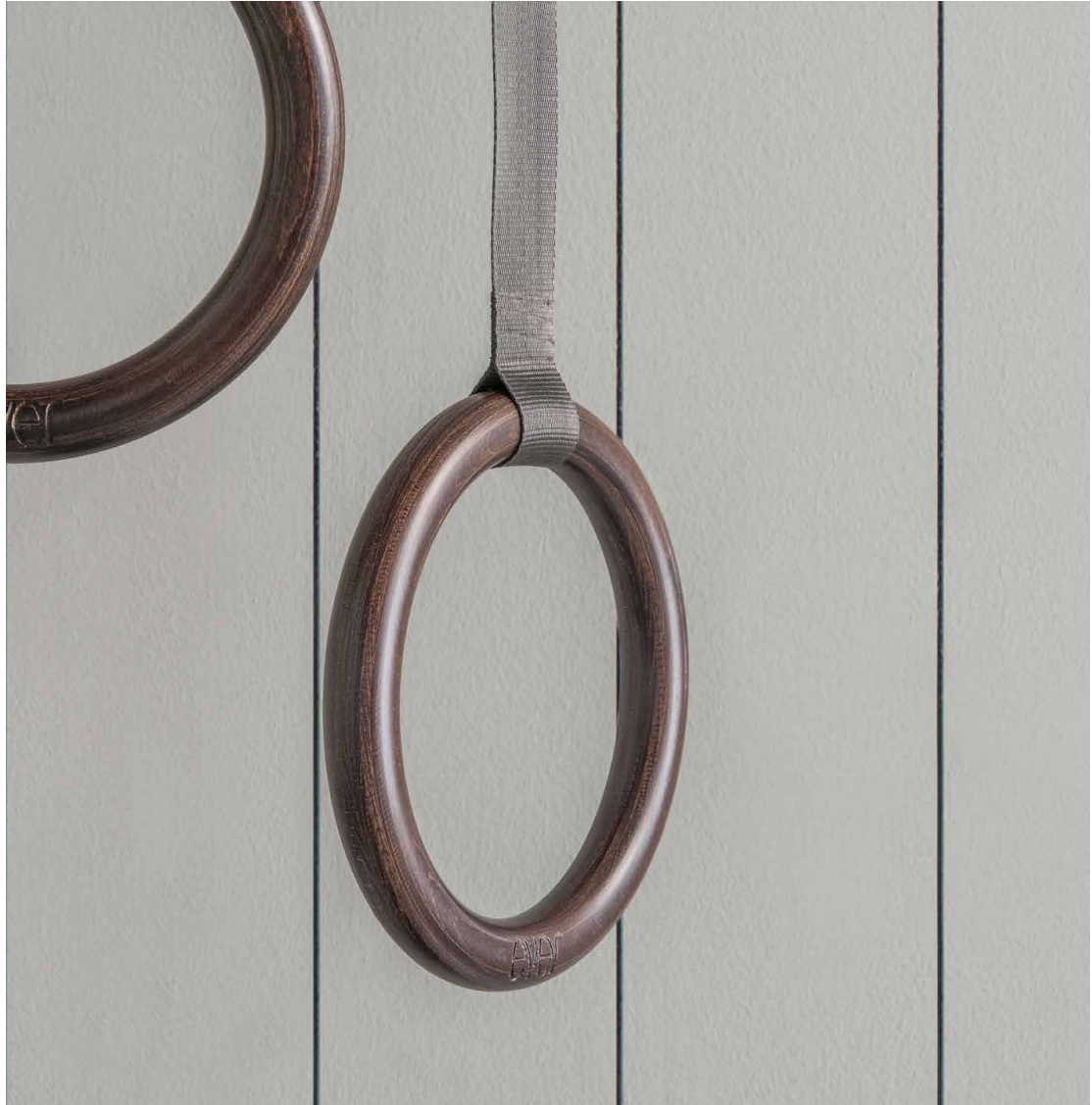



G A M B O L





GAMBOL

GAMBOL

ANELLO E BARRA RING AND BAR

DIMENSIONI mm
DIMENSIONS mm

anello
ring

∅ 235
H 1250-2500

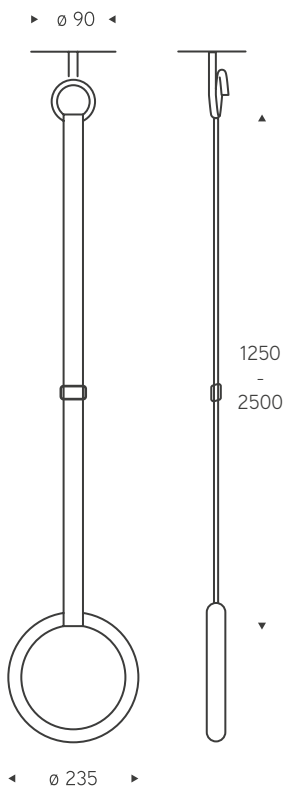

CINGHIA CON FIBBIA
BELT

barra
bar

L 600
H 1250-2500

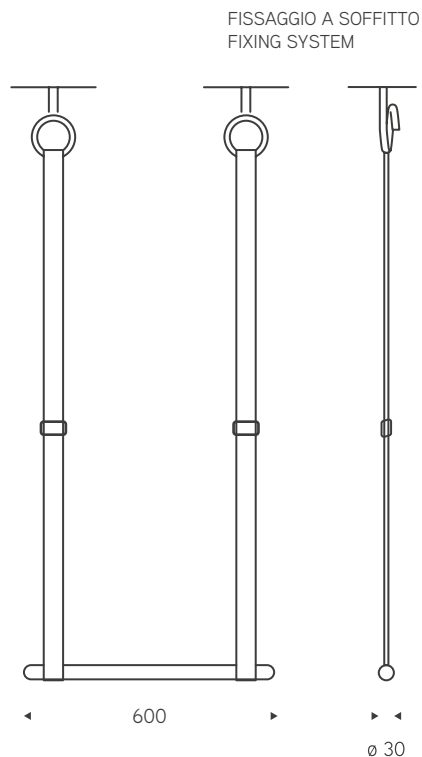

CINGHIA CON FIBBIA
BELT

FISSAGGIO A SOFFITTO
FIXING SYSTEM

VARIANTI E DETTAGLI
VERSIONS AND DETAILS



MATERIALI	anello e barra: legno di faggio cinghie: polipropilene dispositivo per fissaggio: acciaio verniciato
FINITURE	anello: naturale opaco, wengé barra: naturale opaco cinghie: grigio
MATERIALS	ring and bar: beechwood belts: polypropylene belts safety device for ceiling fixing: painted steel
FINISHES	ring: natural opaque, dark-stained wenge barra: natural opaque belts: grey



portascopino **toilet brush holder**

STREET



.....

Design

Diego Cisi
&
Archiplan

.....

Calcestruzzo e ottone danno anima e rendono iconico un oggetto solitamente poco considerato nell'ambiente bagno: il portascopino. Street assume anche una funzione di sostegno, di appoggio per alzarsi e sedersi. Il manico in ottone ed il corpo in calcestruzzo garantiscono sostegno, fino a 120kg di peso.

.....

The toilet brush holder, an iconic object that usually you do not consider in your bathroom, comes alive thanks to concrete and brass. Street, plays also a role of support, in order to help you getting up and sitting down. The handle made in brass and the body made in concrete guarantee support up to 120 kg.

S T R E E T







STREET





STREET

STREET

.....

PORTASCOPINO TOILET BRUSH HOLDER

DIMENSIONI mm
DIMENSIONS mm

portascopino
toilet brush holder

∅ 146
H 642

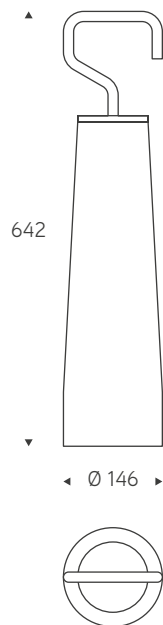

VARIANTI E DETTAGLI VERSIONS AND DETAILS



MATERIALI	corpo: calcestruzzo maniglia: ottone scopino: pvc, nylon
COLORI	corpo: grigio chiaro, grigio scuro maniglia: bianco, rosso segnale, grigio
MATERIALS	body: concrete knob: brass toilet brush: pvc, nylon
COLOURS	handle: light grey, dark grey knob: white, signal red, grey

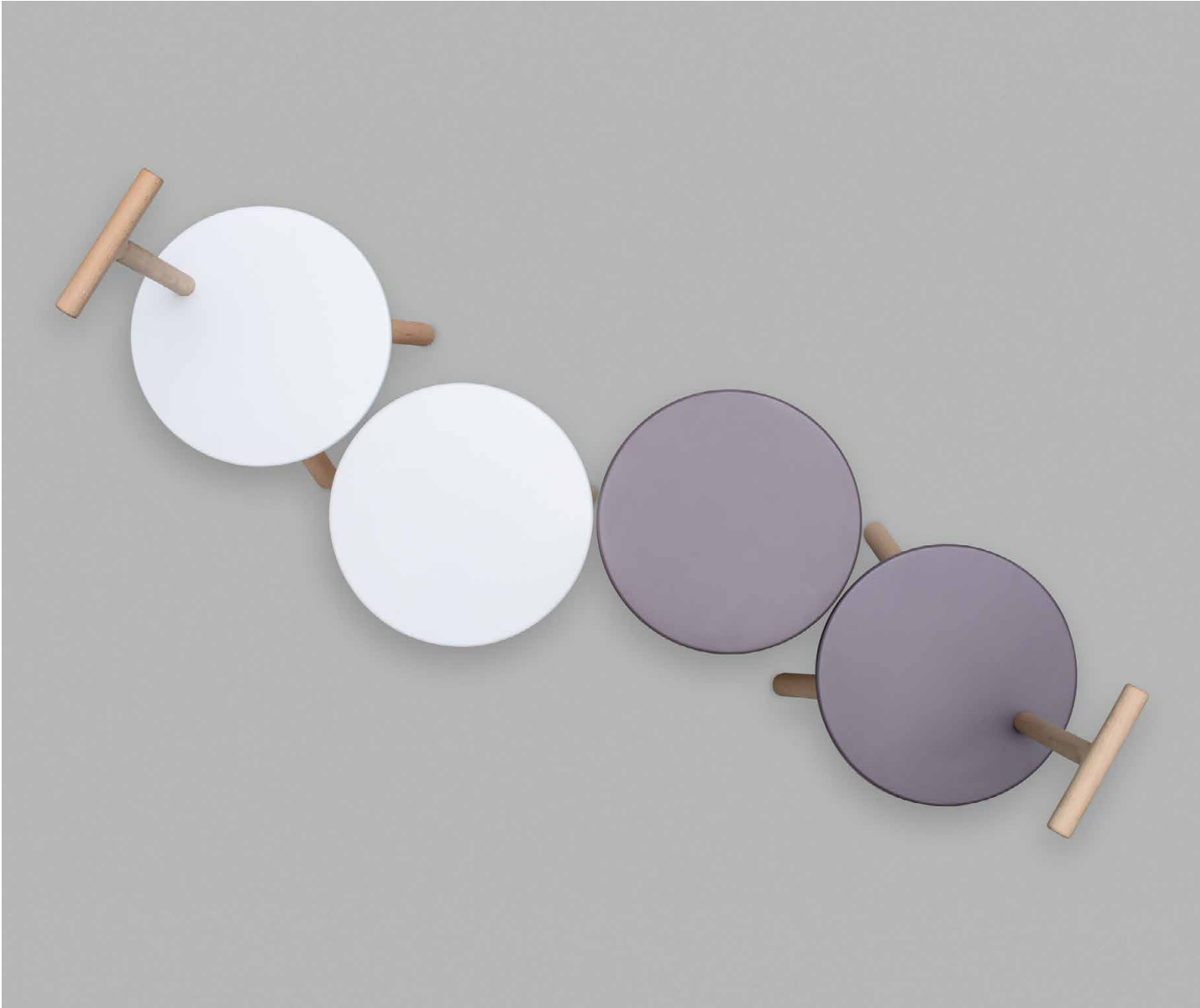

R U N G



.....

Design

Monica
Graffeo

.....

La collezione propone una serie di complementi versatili e nomadi che trovano la loro collocazione in bagno, così come in altre aree della casa. Sedute, appoggi, scale, contenitori. Complementi di accurato design, che animano l'ambiente domestico in modo caldo e rassicurante.

.....

The collection offers a range of versatile and nomadic accessories that find their place in the bathroom, as well as in other areas of the house. Supports, ladders, cabinets. The careful design of these accessories makes them suitable to enliven the home environment in a warm and reassuring way.

R U N G





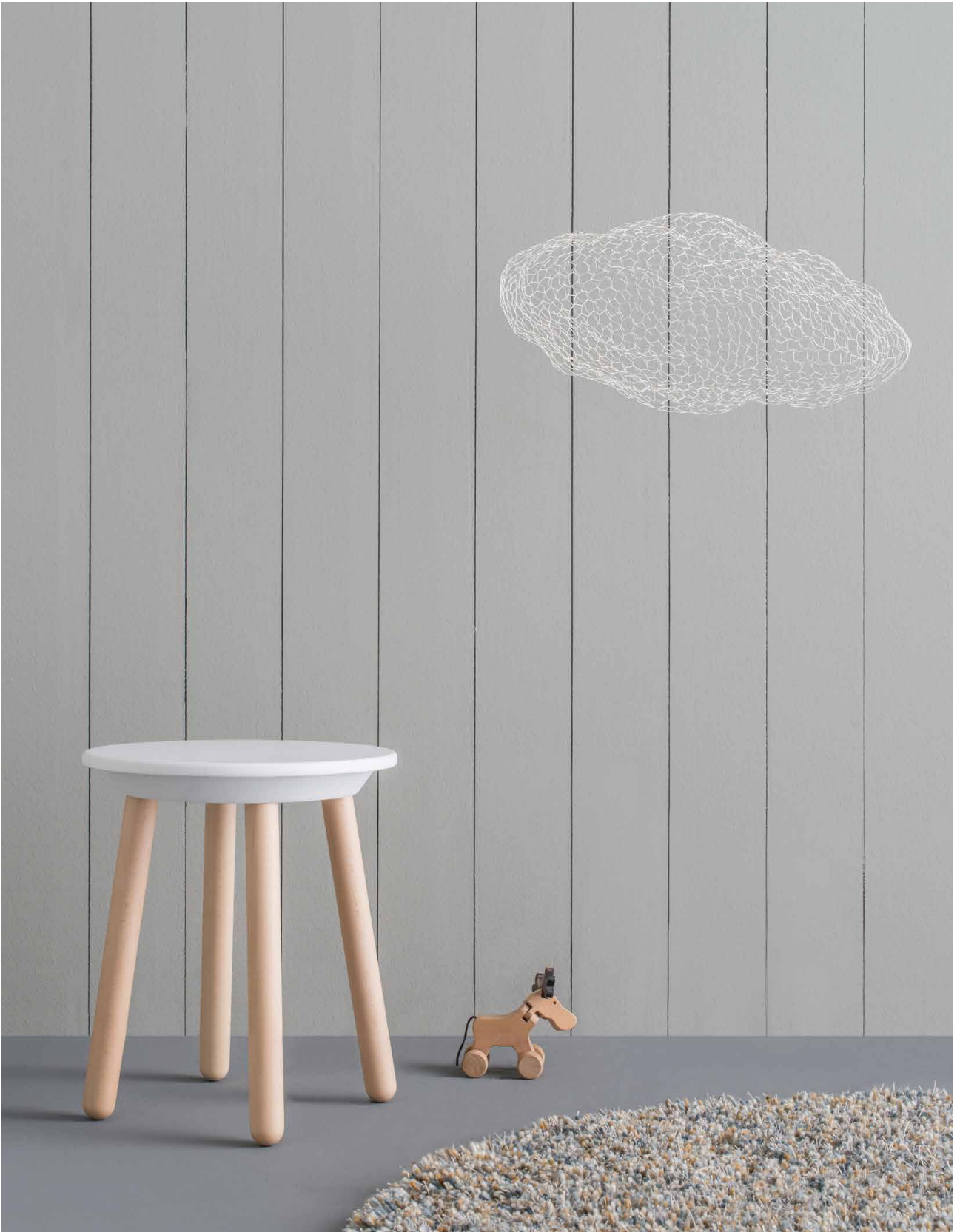

R U N G



SGABELLO CON SUPPORTO
STOOL WITH SUPPORT

CONTENITORE CON SEDUTA
CABINET WITH SEAT



R U N G



RUNG CONTENITORE SCALA

complemento d'arredo strutturato e polifunzionale composto da: contenitore multituoso, presa d'appoggio sicura, portarotolo e specchio reclinabile.

.....

RUNG LADDER CABINET

it is a real structured furnishing accessory, multifunctional: a multipurpose container offering a safe support, a toilet paper holder and a tilting mirror.



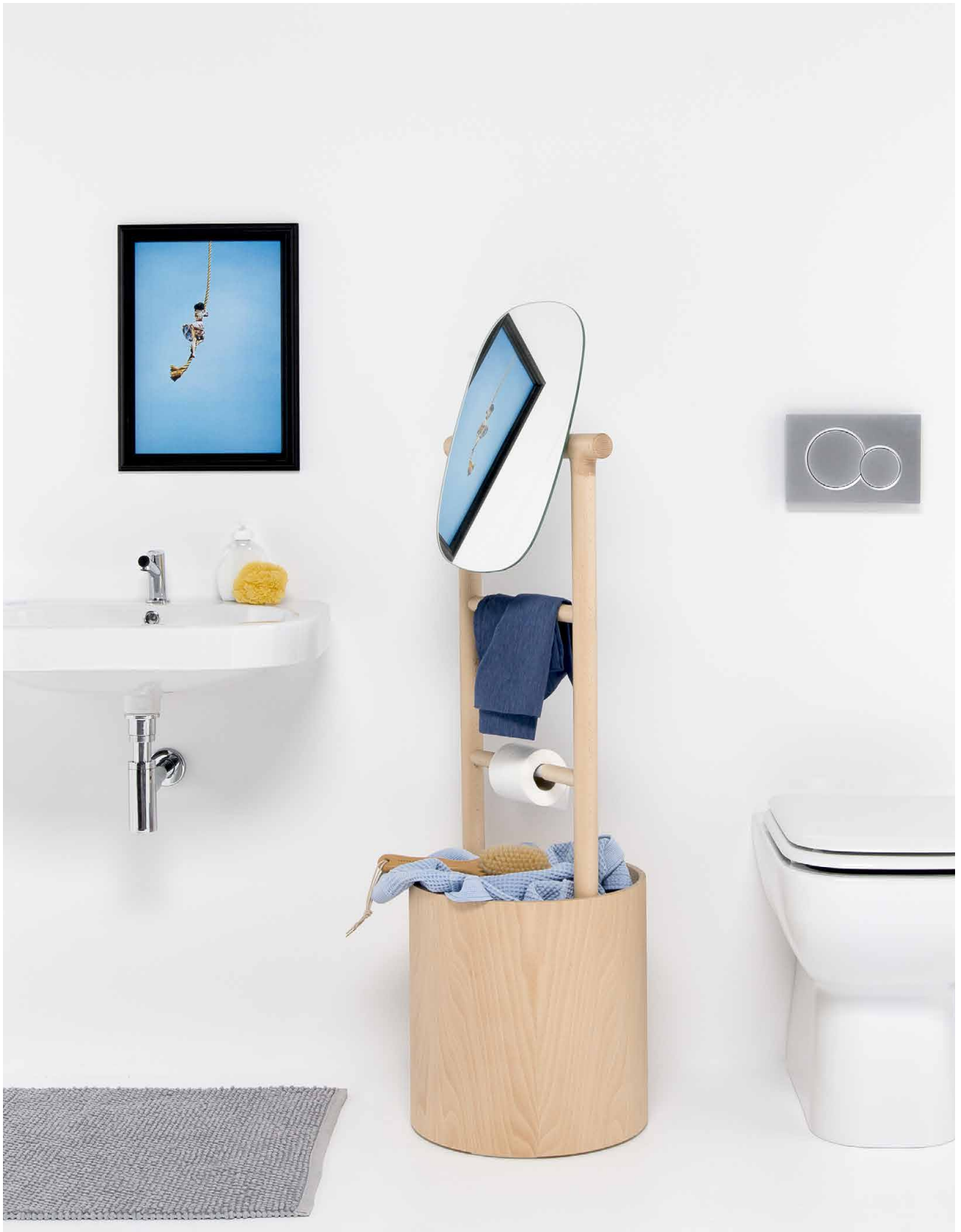



R U N G



RUNG SCALA

grazie ai fissaggi a muro e pavimento, è un sicuro sostegno che funge da portarotoli e salviette. Lo specchio inclinabile si adatta ad ogni esigenza.

.....

RUNG LADDER

Thanks to the fixing system wall mounted or standing on the floor, it is a safety support that you can use as toilet paper holder or as a towel holder. The adjustable mirror is suitable to everyone's needs.



RUNG

SGABELLI STOOLS

DIMENSIONI mm
DIMENSIONS mm

sgabelli stools

ø 380
H 435-815

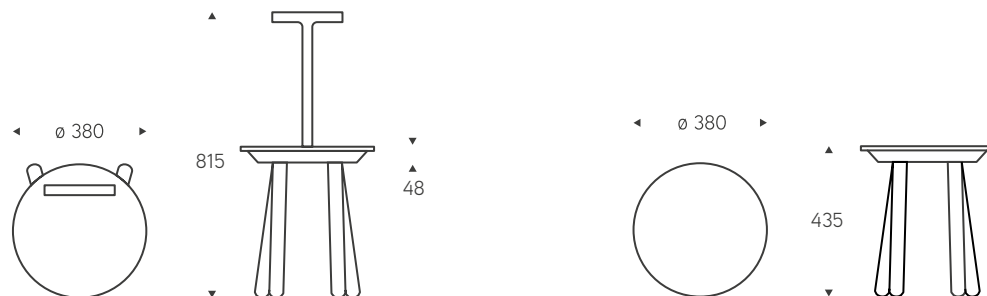

contenitore chiuso closed cabinet

ø 410
H 928

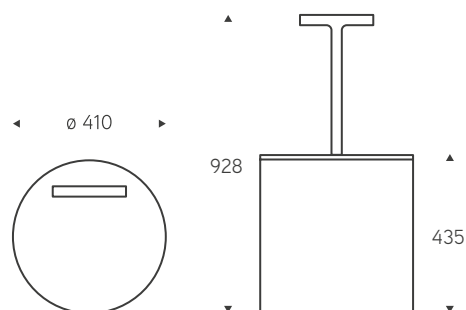

VARIANTI E DETTAGLI VERSIONS AND DETAILS



MATERIALI	legno di faggio, mdf
FINITURE	sedute: bianco opaco, grigio porpora opaco tutti gli altri componenti: legno naturale
MATERIALS	beechwood, mdf
FINISHES	seats: opaque white, opaque purple grey all the other components: natural wood

R U N G

.....

CONTENITORI E SCALE CABINETS AND LADDERS

DIMENSIONI mm
DIMENSIONS mm

scala con contenitore
ladder cabinet

ø 400
H 1163

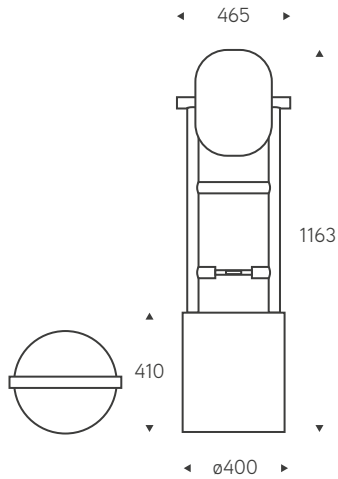

scala
ladder

L 589-627
H 1773
P 111-40

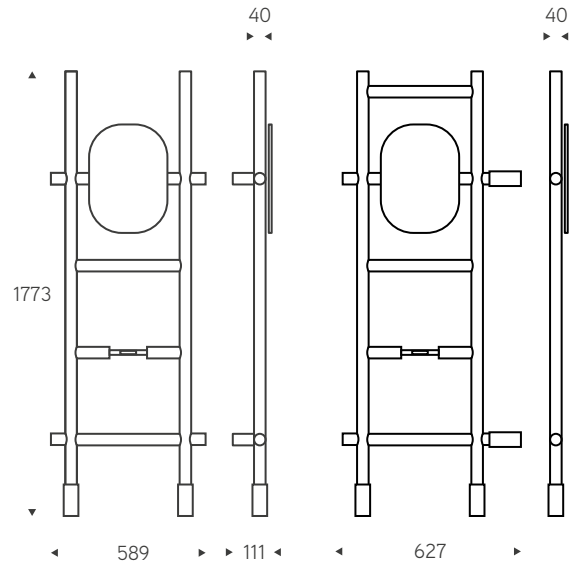

VARIANTI E DETTAGLI
VERSIONS AND DETAILS



MATERIALI
FINITURE

legno di faggio
contenitori: bianco opaco, faggio naturale,
grigio porpora opaco
tutti gli altri componenti: legno naturale

MATERIALS
FINISHES

beechwood
cabinets: opaque white, natural beechwood,
opaque purple grey
all the other components: natural wood



sistema modulare: lavabo e mobile **modular system: washbasin and furniture**



LINK

.....

Design

Diego Cisi
&
Archiplan

.....



LINK



Link permette la configurazione di molte soluzioni di allestimento: il sistema modulare e rettilineo è infatti composto da lavabo in cristalplant e da un mobile contenitore in diverse finiture di legno (rovere europeo oppure ebano Macassar), perfettamente allineabili destra/sinistra e corrispondenti nelle dimensioni.

.....

Link allows the configuration of many installation solutions: the modular straight system is in fact made up of a cristalplant basin and the furniture has different wood finishes (European oak or Macassar ebony), which have the same size of the basin and can be perfectly right / left aligned.



La maniglia offre sostegno e appiglio reggendo un peso/persona massimo di 120 kg.

.....

The handle offers a support, an handhold, with a maximum load weight of 120 kg.



La maniglia frontale è integrata lateralmente per non sporgere, permettendo composizioni di più elementi senza fessurazioni tra gli uni e gli altri.

.....

The front handle is installed laterally in order to avoid protrusions, allowing in this way the realisation of compositions using more elements without cracks between them.



Il modulo contenitore dispone di un vano accessoriato, su richiesta, con una tripla presa elettrica: standard, tedesca e usb. Il coperchio del vano può essere accessoriato, sempre su richiesta, con uno specchio interno.

.....

The furniture module, is complete with an inside space, equipped (on demand) with a triple electrical socket: standard, schuko and usb. The cover can be equipped, on demand, with a mirror inside.





LINK



LINK

MOBILE FURNITURE

DIMENSIONI mm
DIMENSIONS mm

mobile
furniture

L 600
H 170
P 505

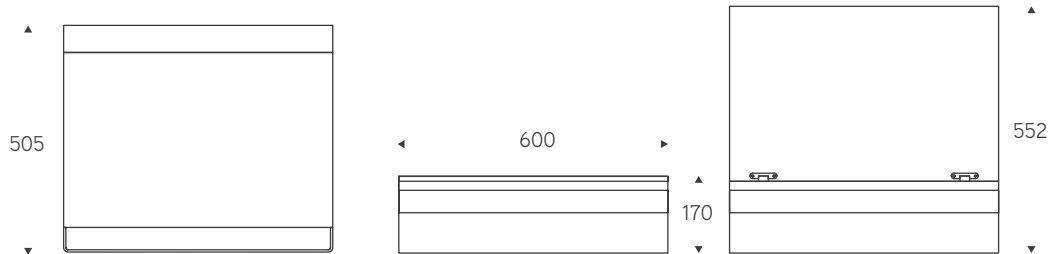

VARIANTI E DETTAGLI
VERSIONS AND DETAILS



MATERIALI mobile: tranciato ebano, tranciato rovere
maniglia: alluminio

PORTATA 120 kg

FINITURE mobile: ebano macassar, rovere europeo

COLORI maniglia: bianco, satinata, nero

MATERIALS furniture: sliced ebony or sliced oak
handle: aluminum

LOAD 120 kg

FINISHES furniture: macassar ebony, european oak

COLOURS handle: white, satin, black

LINK

LAVABO WASHBASIN

DIMENSIONI mm
DIMENSIONS mm

lavabo
washbasin

L 600
H 170
P 505

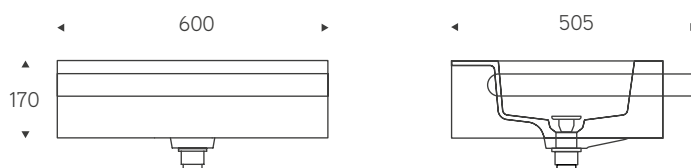

VARIANTI E DETTAGLI VERSIONS AND DETAILS



MATERIALI	lavabo: cristalplant maniglia: alluminio
PORTATA	120 kg
COLORI	maniglia: bianco, satinata, nero
VERSIONS	fori rubinetteria: senza, 1, 3
MATERIALS	washbasin: cristalplant handle: aluminum
LOAD	120 kg
COLOURS	handle: white, satin, black
VERSIONS	holes for faucets: without, 1, 3

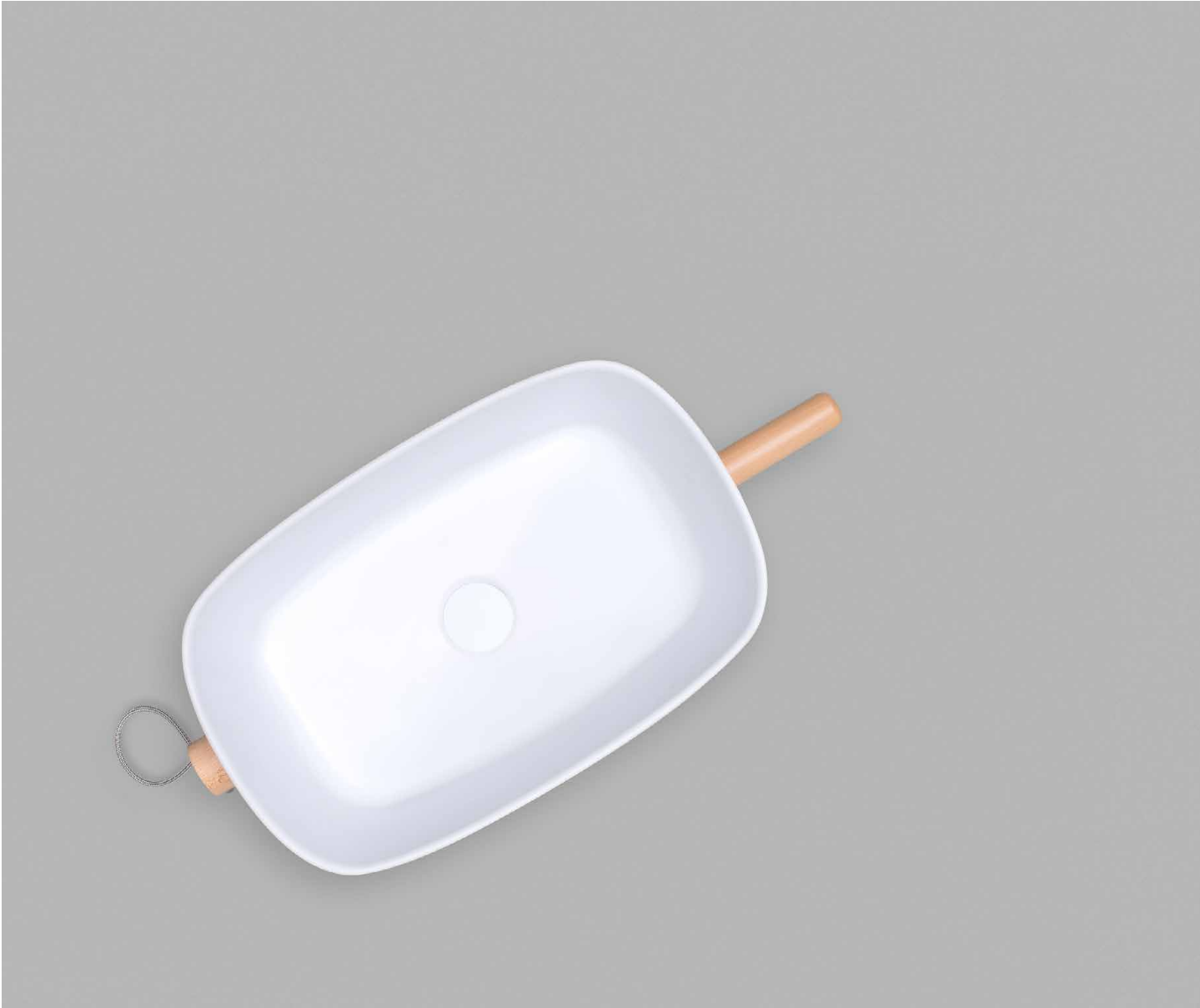

lavabo morbido poliuretano o cristalplant **soft washbasin polyurethane or cristalplant**

B O U N C E



Eccellenze
della Lombardia

.....

Design

Monica
Graffeo

.....

SOFT OR STRONG?

LAVABO IN POLIURETANO O
CRISTALPLANT

POLYURETHANE OR CRISTALPLANT
WASHBASIN

Bounce è un lavabo dalle linee pulite e morbide, che trae spunto dalla tradizione della cucina. La sua forma, abbinata ai diversi accessori disponibili, ricorda le forme archetipe di pentole e tegami, trasportate nel contesto bagno per creare un effetto rassicurante. Assolutamente innovativo è invece il materiale utilizzato: il poliuretano.

Un materiale, dalla texture liscia e setosa, morbido al tatto che si abbina perfettamente alla linea essenziale di Bounce.

Disponibile anche in Cristalplant.

.....

Bounce is a washbasin of soft and neat lines, inspired by the kitchen traditions. Its shape, together with the various relevant accessories available, recalls the archetypical shapes of pots and pans transposed into the context of the bathroom to create a reassuring effect. Completely innovative is the material used: polyurethane. A material with a smooth and silky texture, soft to the touch, which perfectly matches Bounce's essential shape that make it extremely customizable. Available also in Cristalplant.



B O U N C E



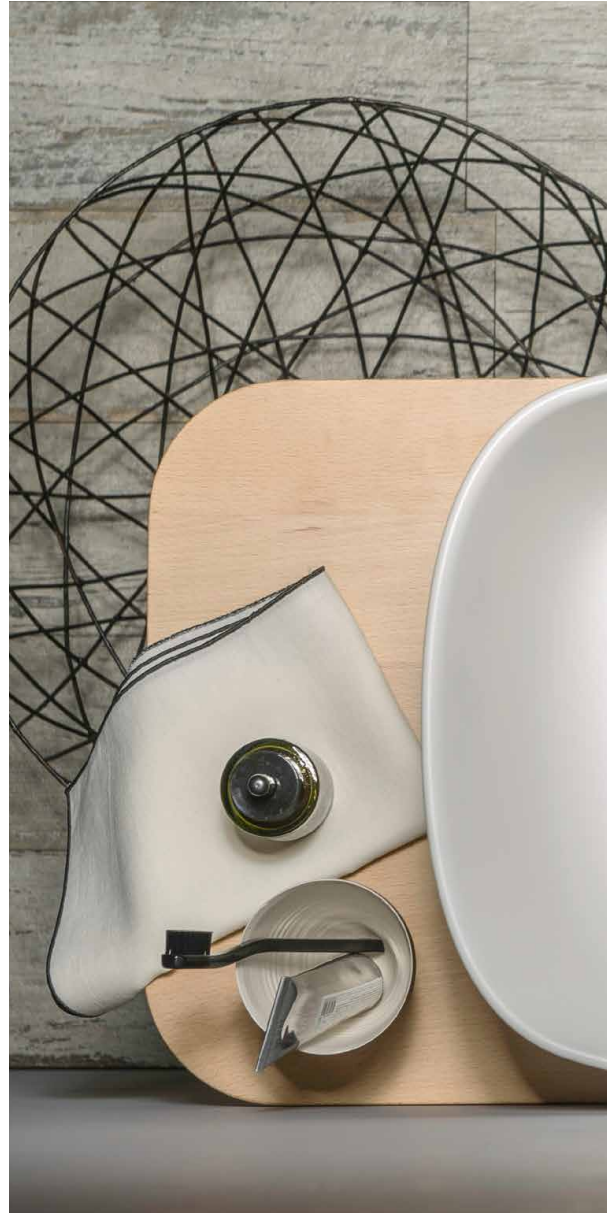
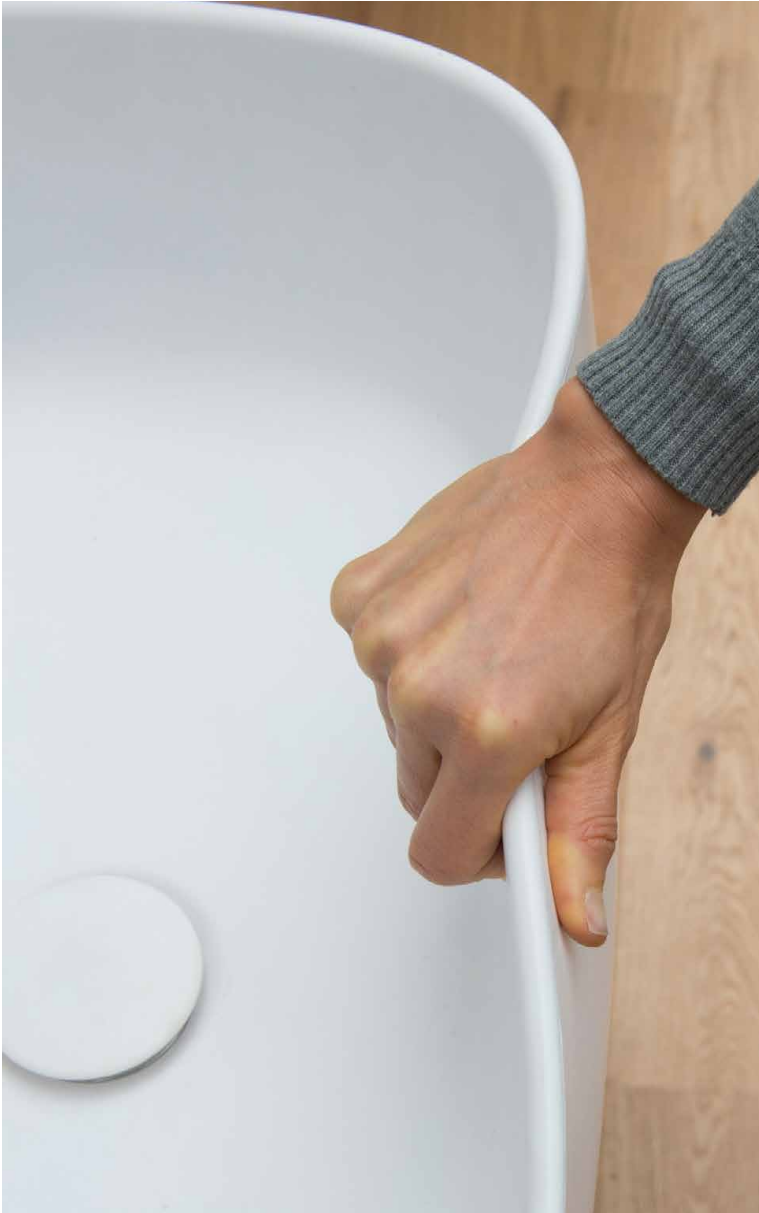

BOUNCE





BOUNCE





BOUNCE



Varianti
versions:

BOUNCE

lavabo
washbasin

BOUNCE HUG

lavabo con portasciugamani
avvolgente
washbasin with enveloping
towel holder

BOUNG CORD

lavabo con portasciugamani
laterale in corda
washbasin with side towel
holder made of rope

BOUNCE COUNTER

lavabo con mensola di
appoggio in faggio
washbasin with floating shelf

BOUNCE PAN

lavabo con appendi oggetti
orizzontale e portasciugamani
laterale in corda
washbasin with orizontal
hanger and side towel holder
made of rope

TUTTE LE VARIANTI SONO
DISPONIBILI ANCHE IN
CRISTALPLANT

ALL VERSIONS ARE ALSO
AVAILABLE IN CRISTALPLANT



BOUNCE

B O U N C E



BOUNCE HUG



BOUNCE CORD



BOUNCE PAN



BOUNCE COUNTER

B O U N C E

LAVABO WASHBASIN

DIMENSIONI mm
DIMENSIONS mm

Bounce

L 560
H 180
P 356

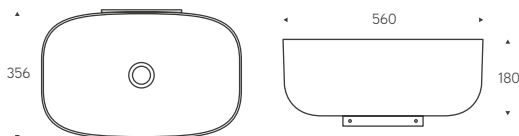

Bounce Counter

L 877
H 210
P 363

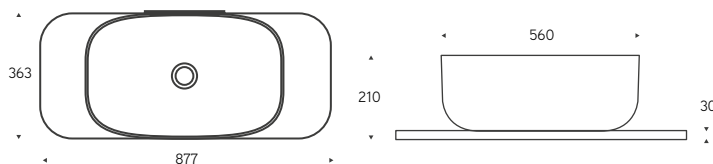

VARIANTI E DETTAGLI VERSIONS AND DETAILS



Bounce



Bounce Hug



Bounce Cord



Bounce Pan



Bounce Counter

POLYURETHANE

MATERIALI

lavabo: POLIURETANO INTEGRALE
accessori: legno massello di faggio naturale
staffe/telaio: acciaio al carbonio con trattamento galvanico e verniciatura a polvere

PORTATA

150 kg (il presente carico non è riferito agli accessori in faggio)

FINITURA

finitura superficiale liscia

COLORI

bianco

DOTAZIONI

piletta in ottone cromato inclusa, con tappo in Corian bianco, sempre aperto. Versione Click-Clack a richiesta.

TROPPO PIENO

non presente

MATERIALS

washbasin: INTEGRAL POLYURETHANE
accessories: natural solid beechwood
brackets/frame: carbon steel with galvanic treatment and powder coating

LOAD

kg 150 (this load is not referred to beechwood accessories)

FINISHES

smooth surface finishing

COLOURS

white

EQUIPMENT

chromed-plated drain included, white Corian plug, always open plug. Click-Clack plug on request

OVERFLOW

not included

B O U N C E

LAVABO WASHBASIN

DIMENSIONI mm
DIMENSIONS mm

Bounce Hug

L 602
H 180
P 414

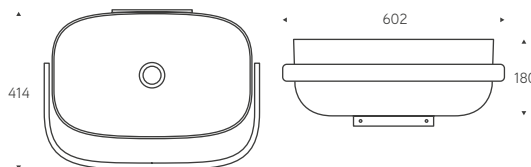

Bounce Cord

L 586
H 180
P 351

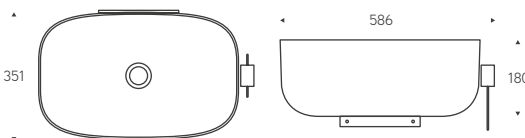

Bounce Pan

L 715
H 180
P 352

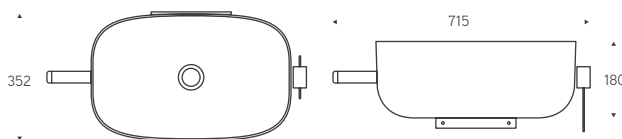

VARIANTI E DETTAGLI
VERSIONS AND DETAILS



Bounce



Bounce Hug



Bounce Cord



Bounce Pan



Bounce Counter

CRISTALPLANT

MATERIALI	lavabo: CRISTALPLANT accessori: legno massello di faggio naturale
PORTATA	150 kg (il presente carico non è riferito agli accessori in faggio)
FINITURA	finitura superficiale liscia
COLORI	bianco
DOTAZIONI	piletta in plastica, tappo click-clack in ottone verniciato bianco
TROPPO PIENO	non presente
MATERIALS	washbasin: cristalplant accessories: natural solid beechwood
LOAD	kg 150 (this load is not referred to beechwood accessories)
FINISHES	smooth surface finishing
COLOURS	white
EQUIPMENT	plastic drain with white painted brass Click-Clack system included
OVERFLOW	not included



lavabo **washbasin**



S T O N Y

.....

Design

Thermomat

.....

Stony è realizzato mediante un impasto di marmo resina colorato in massa. Il marmo resina è un materiale estremamente solido, igienico e facile da pulire grazie alla superficie non porosa e non assorbente. Forme sinuose, prive di angoli vivi, superficie liscia di forte impatto materico, danno un tocco di ecletticità al bagno.

.....

Stony is made in stone-resin mass dyed. The stone-resin is an extremely strong and durable material, and it gives to this washbasin a strong nature; easy to clean thanks to a non-porous and non-absorbent surface. Rounded mould, free of sharp corners, incredibly emotional smooth surface: an eclectic touch for your bathroom.

S T O N Y

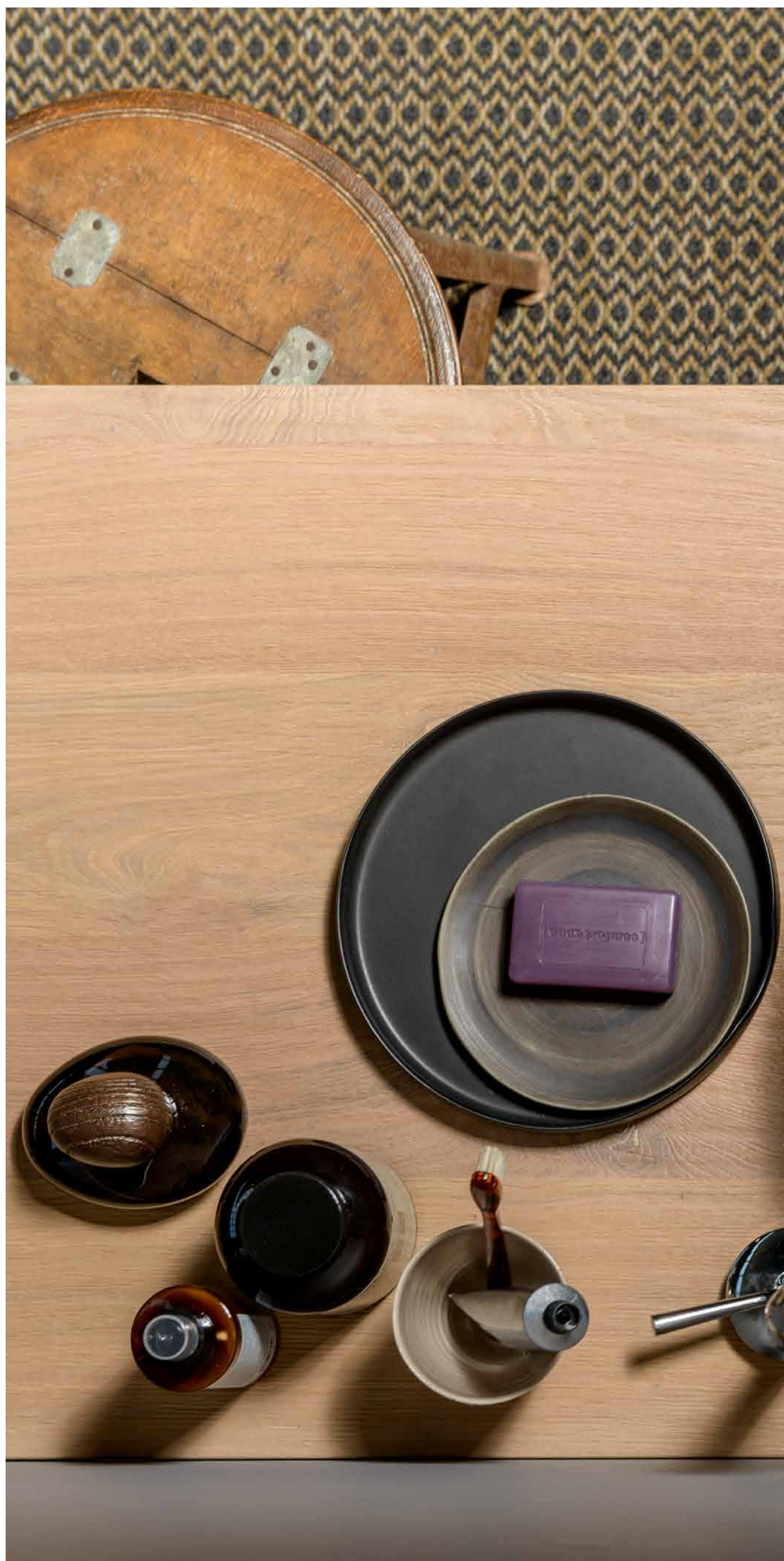





STONY





STONY

STONY

LAVABO WASHBASIN

DIMENSIONI mm
DIMENSIONS mm

Stony lavabo
Stony washbasin

ø 430
H 180

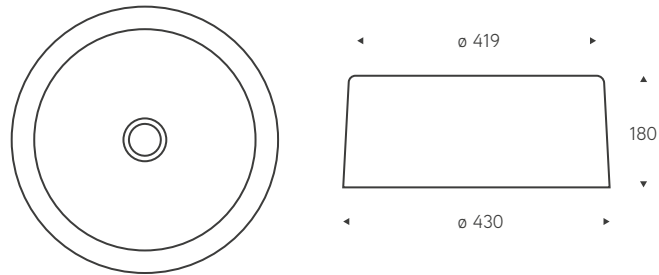

foro piletta scarico 1"1/4
drainage hole 1" 1/4

VARIANTI E DETTAGLI VERSIONS AND DETAILS



MATERIALI	marmo sbriciolato unito da una matrice di resina con un processo di polimerizzazione chimica
FINITURE	effetto pietra
COLORI	bianco, crema, antracite, grigio cemento
PILETTA	piletta in ottone cromato da 1" 1/4 G in dotazione, tappo sempre aperto, (tappo click-clack a richiesta)
TROPPO PIENO	non presente
MATERIALS	crushed marble combined by a resin matrix through a chemical polymerization process
FINISHES	stone effect
COLOURS	white, cream, anthracite, cement grey
DRAIN	1/4 G chrome-plated drain included, always open plug, ("click-clack" plug on request)
OVERFLOW	not included

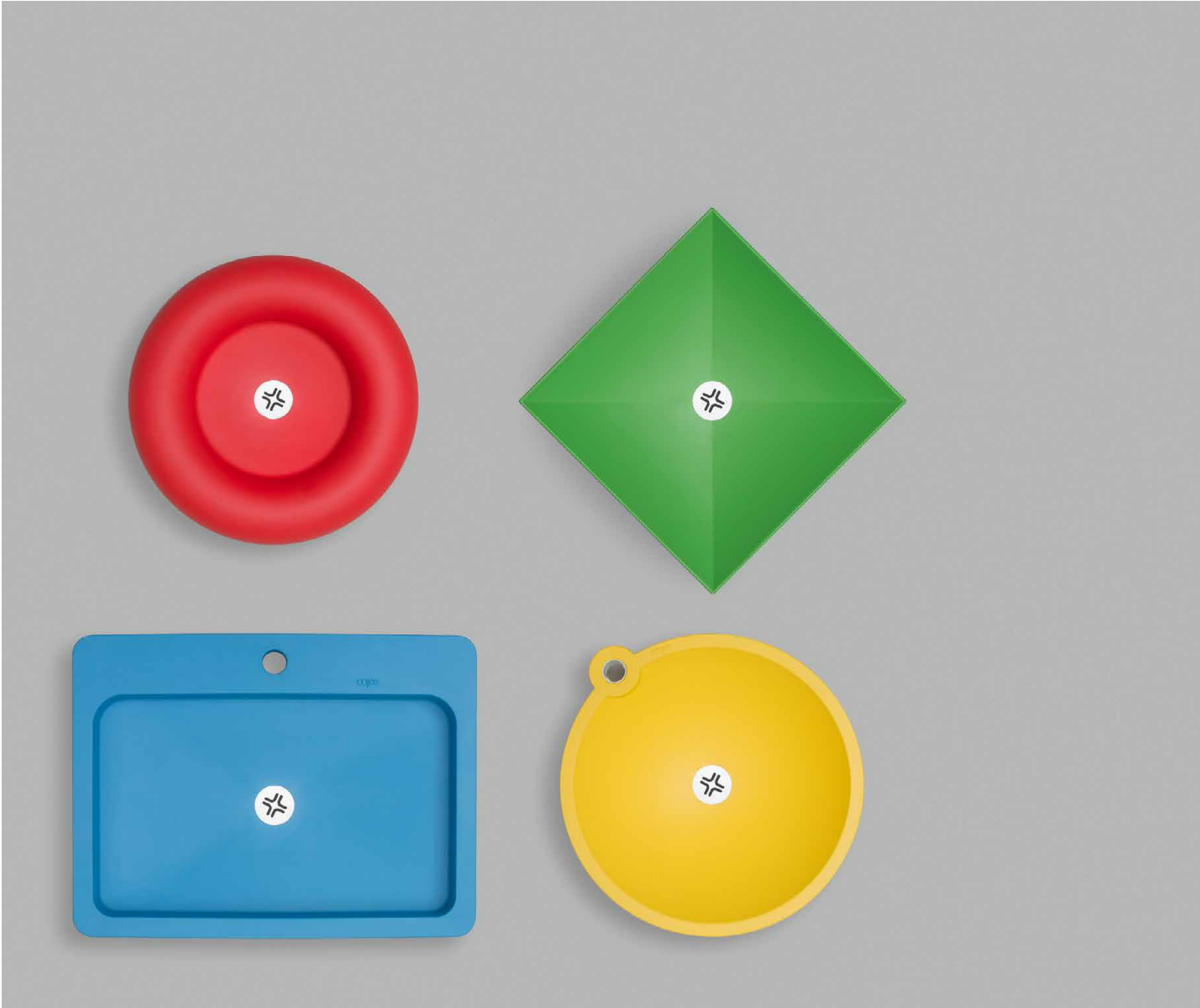

lavabi e accessori **washbasins and accessories**



B O I N G

Lavabi e accessori BOING sono soffici al tocco, offrono sicurezza antiurto e comfort grazie al materiale di cui sono fatti: il poliuretano. Colorati, piacevoli da vedere e di grande effetto in tutti gli ambienti bagno, sono la scelta ideale per tutti coloro che ricercano qualcosa di originale e innovativo e ripensano il loro mondo domestico con occhi diversi in termini di materiali, forme e esperienze cromatiche.

.....

Washbasins and accessories BOING are soft to the touch, offering safety from hurts and comfort thanks to the material they are made of: polyurethane. Colorful, nice to look at and highly effective in all bathroom environments, they are the ideal choice for anyone looking for something original and innovative, re-thinking their home world with different eyes in terms of materials, shapes and color experiences.

BOING







BOING

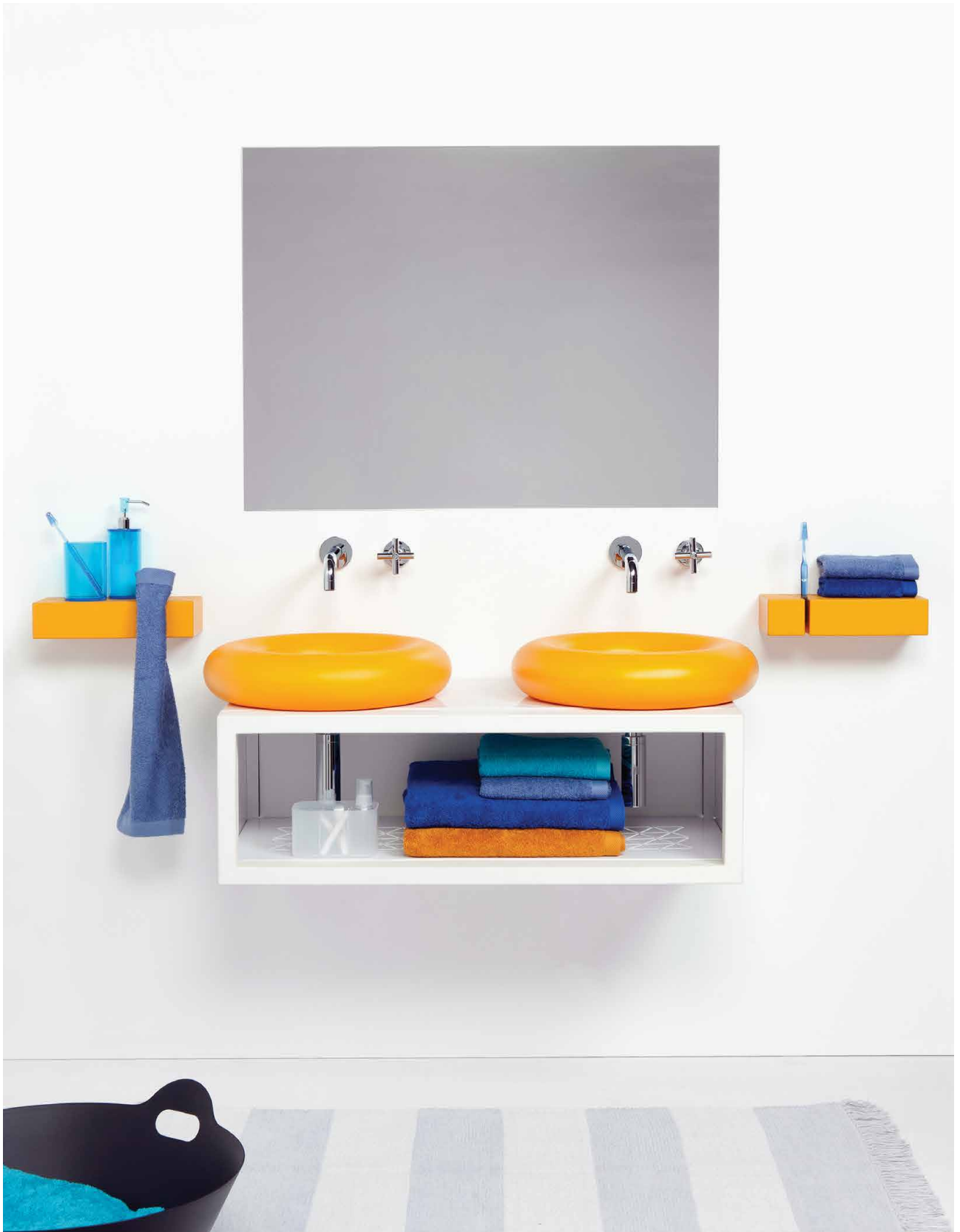



BOING

BOING

LAVABI WASHBASINS

DIMENSIONI mm
DIMENSIONS mm

Tipo

L 598
H 88
P 448

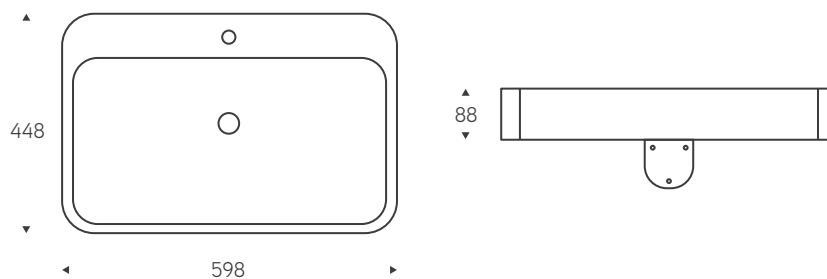

Kubo

L 400
H 400
P 400

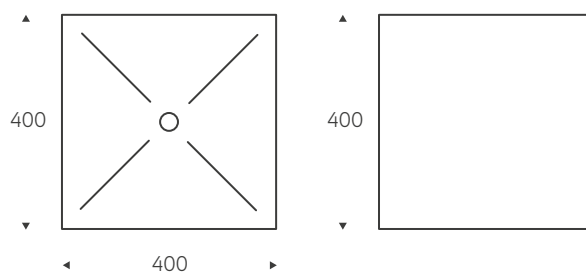

VARIANTI E DETTAGLI VERSIONS AND DETAILS

Tipo



Kubo



MATERIALI poliuretano morbido
PILETTA foro piletta standard
INSTALLAZIONE Tipo: a muro o appoggio
Kubo: a muro

MATERIALS soft polyurethane
DRAIN standard
MOUNTING Tipo: standing or wall mounted
Kubo: wall mounted

COLORI
COLOURS



BOING

LAVABI WASHBASINS

DIMENSIONI mm
DIMENSIONS mm

Orbita

∅ 440
H 150

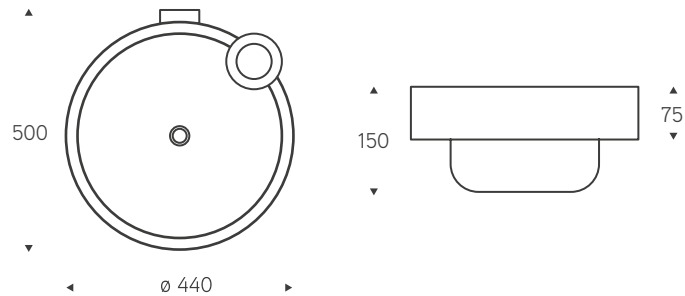

Salvagente

∅ 445
H 100

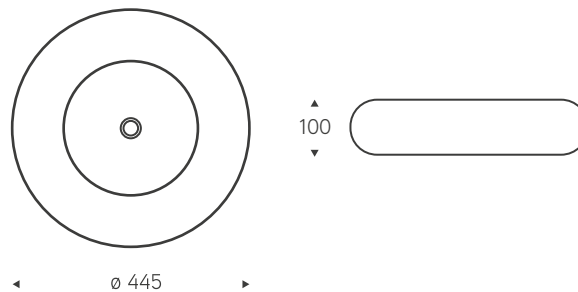

VARIANTI E DETTAGLI VERSIONS AND DETAILS



Orbita



Salvagente

MATERIALI poliuretano morbido
DOTAZIONI foro piletta standard, scarico con griglia
INSTALLAZIONE Orbita: a muro o appoggio
Salvagente: a muro o appoggio
MATERIALS soft polyurethane
EQUIPMENT standard siphon hole, grid drain system supplied
MOUNTING Orbita: standing or wall mounted
Salvagente: standing or wall mounted

COLORI
COLOURS



3020 6018 4010 1018 1028



5012 9017 5021 1019

BOING

.....

MENSOLA PORTASCIUGAMANI TOWEL SHELF

DIMENSIONI mm
DIMENSIONS mm

Toxo

L 300
H 70
P 140

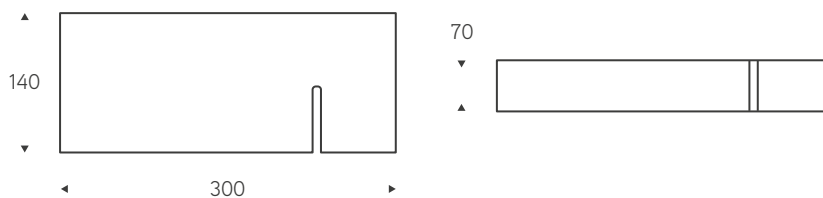

VARIANTI E DETTAGLI VERSIONS AND DETAILS



Toxo

MATERIALI

poliuretano morbido

MATERIALS

soft polyurethane

COLORI

COLOURS



3020

6018

4010

1018

1028



5012



9017



5021



1019



sanitari **sanitary ware**



SANITARI

sanitary ware



EASY 42



EASY 42

I sanitari della serie EASY 42, caratterizzati da una superficie esterna liscia e lineare, riportano a un design minimalista ed essenziale. E' una collezione volutamente discreta, che si inserisce in maniera armonica realmente in ogni ambiente. Realizzati in ceramica bianca, sono disponibili solo nella versione a pavimento.

.....

EASY 42, a range of sanitaryware with a smooth and polish surface, with minimalist design. A collection deliberately discreet, which fits harmoniously everywhere, and ensures harmony with the decor of any interior.

Made of white ceramic, only floor standing version is available.





EASY 42

.....

VASO A PAVIMENTO FLOOR STANDING WC

DIMENSIONI mm
DIMENSIONS mm

Vaso
wc

L 350
H 420
P 520

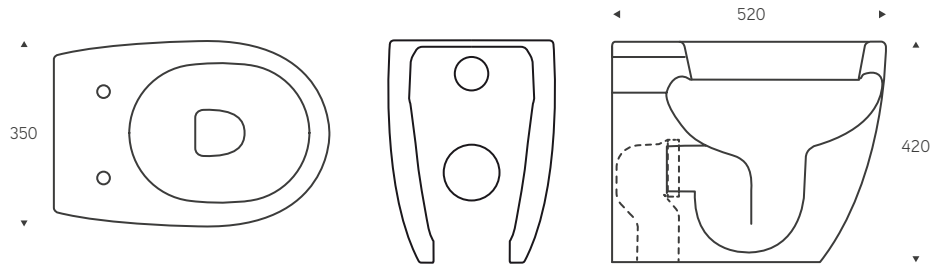

VARIANTI E DETTAGLI
VERSIONS AND DETAILS



MATERIALI	vaso: vitreous china sedile: duroplast, gomma, ottone, acciaio
SCARICO WC	unificato
SEDILE	sedile con coperchio per vaso versioni: standard, soft close
MATERIALS	vitreous china seat: duroplast, rubber, brass, steel
DRAINAGE	single
SEAT	seat with cover for wc versions: standard, soft close

note tecniche **technical details**

EASY 42

.....

BIDET A PAVIMENTO FLOOR STANDING BIDET

DIMENSIONI mm
DIMENSIONS mm

bidet
bidet

L 550
H 420
P 520

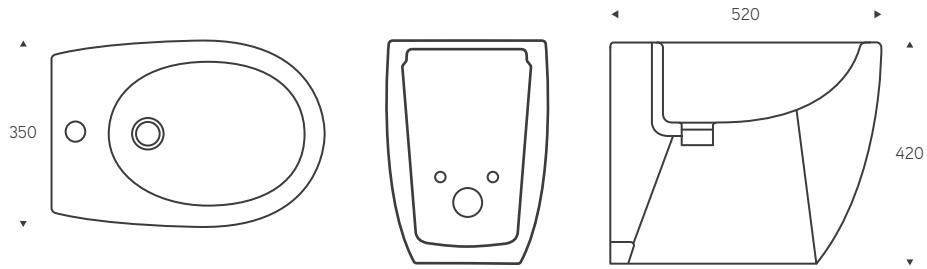

VARIANTI E DETTAGLI
VERSIONS AND DETAILS



MATERIALI vitreous china
MATERIALS vitreous china

EVERY 44

La serie EVERY 44 richiama le forme lineari della precedente ma è anche fortemente caratterizzata da un bordo distintivo particolarmente raffinato. Volumi compatti e semplicità formale sono frutto di un design contemporaneo che si integra perfettamente in qualsiasi ambiente bagno. Realizzati in ceramica bianca e disponibili nella versione a pavimento, sospesa e monoblocco.

.....

The line EVERY 44 looks like the same simple shapes of the previous one, but it is characterised also by a sophisticated edge, one of the line's distinguishing features. Compact and simple, markings which are the result of a contemporary design, that fits perfectly in each bathroom.

Made of white ceramic, they are available in a few versions: floor standing, hanging and close coupled.

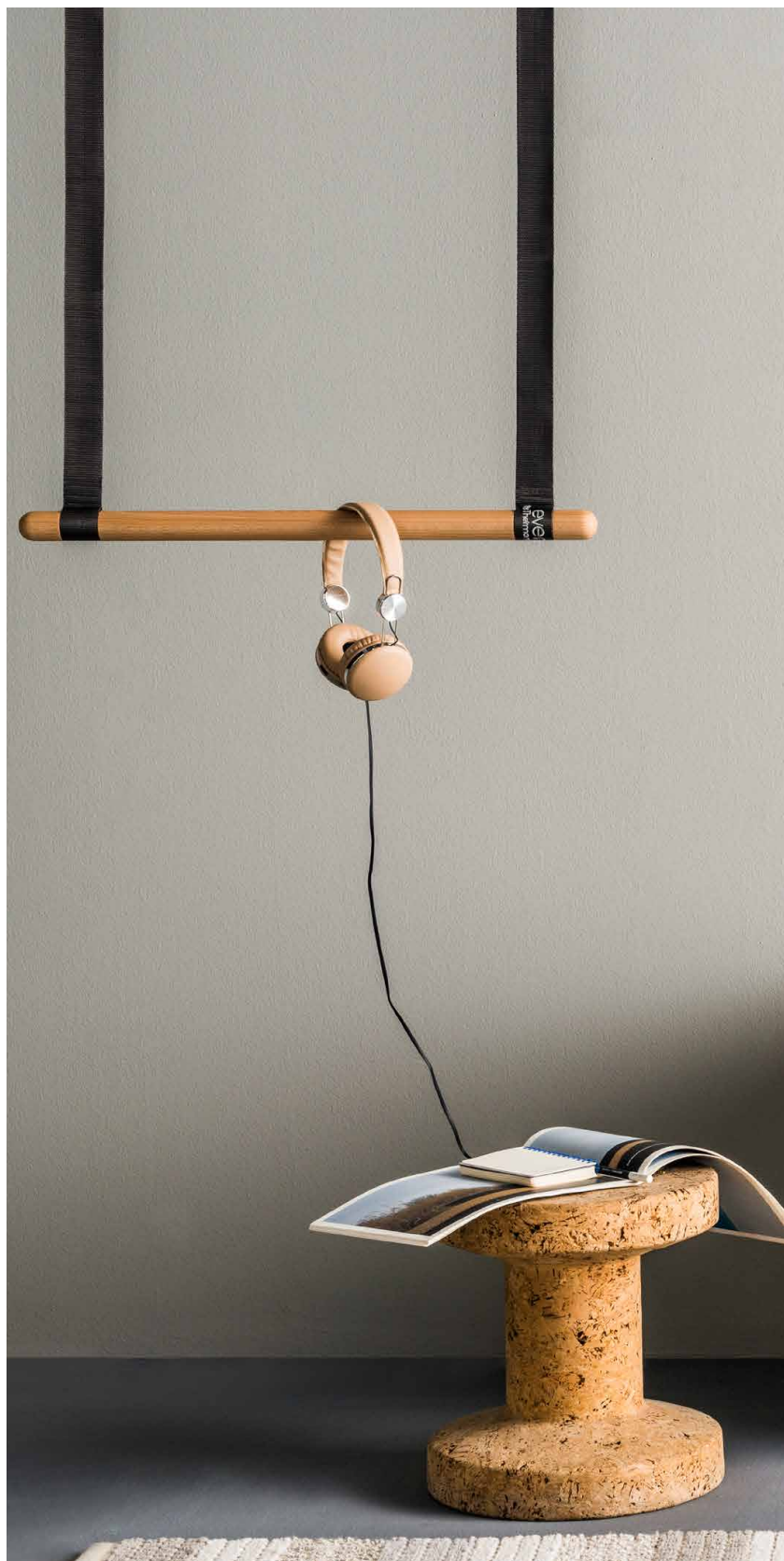













EVERY 44

SANITARI A TERRA FLOOR STANDING SANITARYWARE

DIMENSIONI mm
DIMENSIONS mm

vaso
wc

L 365
H 440
P 520

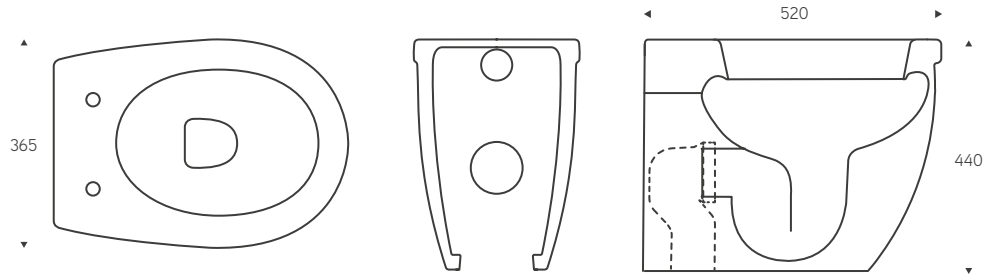

bidet
bidet

L 365
H 440
P 520

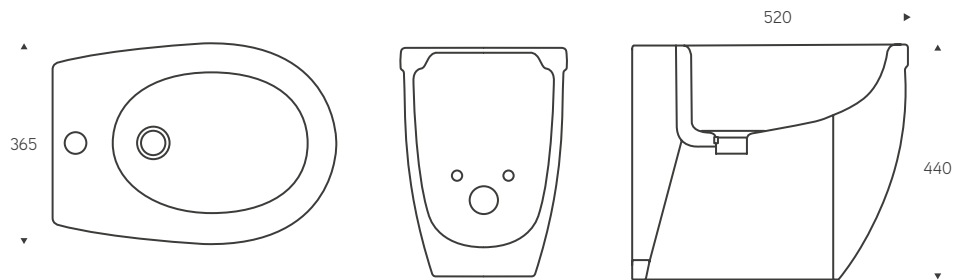

VARIANTI E DETTAGLI
VERSIONS AND DETAILS



MATERIALI	vaso: vitreous china sedile: duroplast, gomma, ottone, acciaio
SCARICO WC	unificato
SEDILE	sedile con coperchio per vaso versioni: standard, soft close
MATERIALS	vitreous china seat: duroplast, rubber, brass, steel
DRAINAGE	single
SEAT	seat with cover for wc versions: standard, soft close

EVERY 44

SANITARI SOSPESI HANGING SANITARYWARE

DIMENSIONI mm
DIMENSIONS mm

vaso sospeso
hanging wc

L 370
H 265
P 515

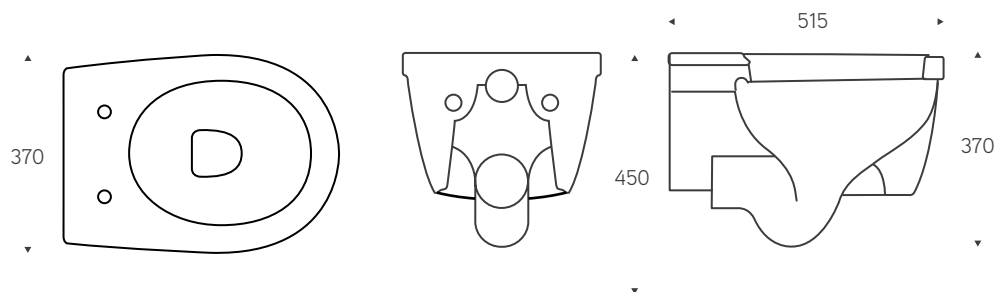

bidet sospeso
hanging bidet

L 370
H 265
P 515

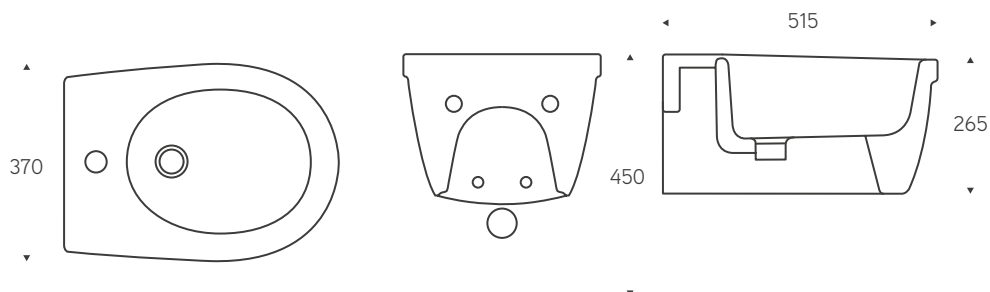

VARIANTI E DETTAGLI
VERSIONS AND DETAILS



MATERIALI	vaso: vitreous china sedile: duroplast, gomma, ottone, acciaio
SCARICO WC	unificato
SEDILE	sedile con coperchio per vaso versioni: standard, soft close
MATERIALS	vitreous china seat: duroplast, rubber, brass, steel
DRAINAGE	single
SEAT	seat with cover for wc versions: standard, soft close

note tecniche **technical details**

EVERY 44

VASO MONOBLOCCO CLOSE COUPLED FLOOR STANDING WC

DIMENSIONI mm
DIMENSIONS mm

Vaso
WC

L 370
H 900
P 640

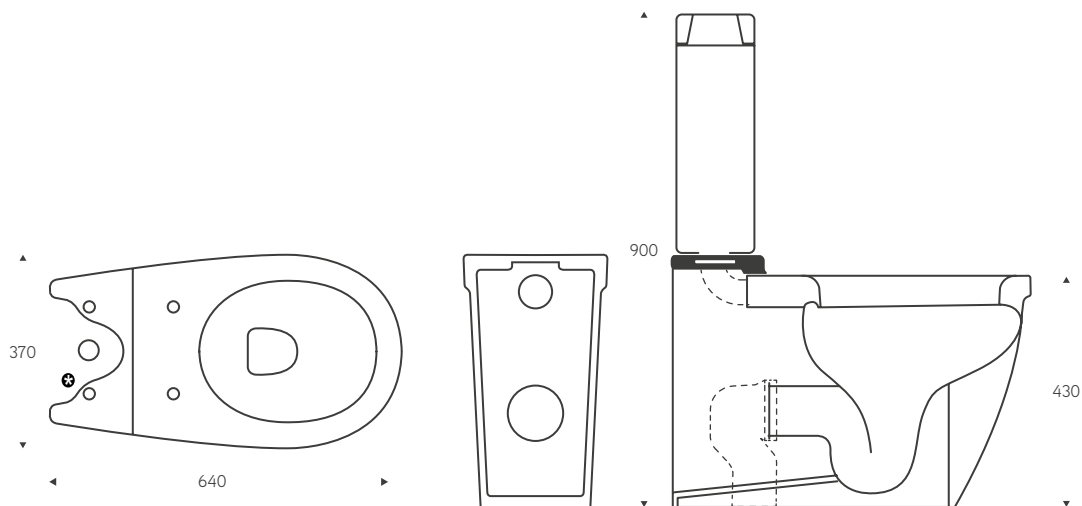

VARIANTI E DETTAGLI VERSIONS AND DETAILS



MATERIALI	vaso: vitreous china sedile: duroplast, gomma, ottone, acciaio
SCARICO WC	unificato
SEDILE	sedile con coperchio per vaso versioni: standard, soft close
ACCESSORI	sistema di scarico e collegamento per vaso monoblocco
MATERIALS	vitreous china seat: duroplast, rubber, brass, steel
DRAINAGE	single
SEDILE	seat with cover for wc versions: standard, soft close
ACCESSORIES	drainage and connection system for close coupled wc



SENIOR 46

SENIOR 46



I sanitari SENIOR 46 hanno linee eleganti e pulite, il WC ed il bidet sono alti 46 cm per facilitare i movimenti di seduta e di rialzo. Completa la serie un lavabo dal design estremamente accattivante che si abbina perfettamente a tutti gli ambienti bagno, dai più moderni ai più tradizionali.

.....

SENIOR 46 sanitaryware series has got elegant and clean shapes, the WC and the bidet are 46 cm high to make the movements of seating and getting up much easier. The series is completed by a washbasin whose extremely catching design can match perfectly with all bathroom environments, from the most modern to the traditional ones.

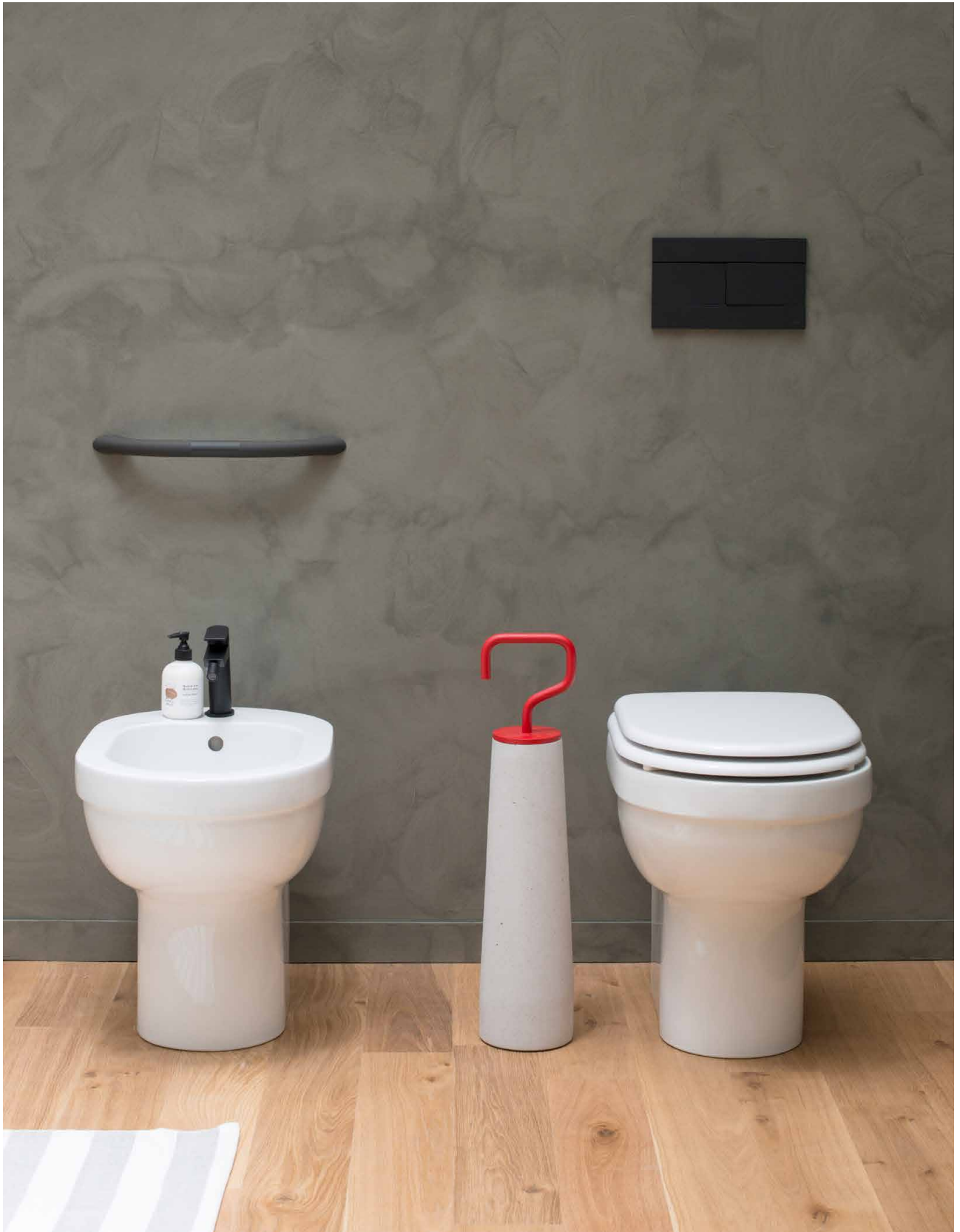

SENIOR 46



SENIOR 46

SANITARI SANITARY WARE

DIMENSIONI mm
DIMENSIONS mm

vaso

wc

L 380

H 460

P 560

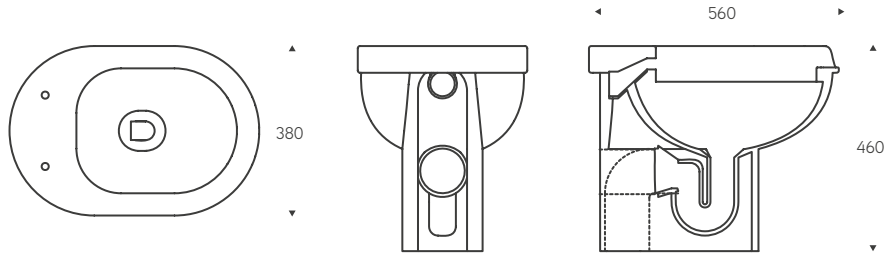

bidet

bidet

L 380

H 460

P 560

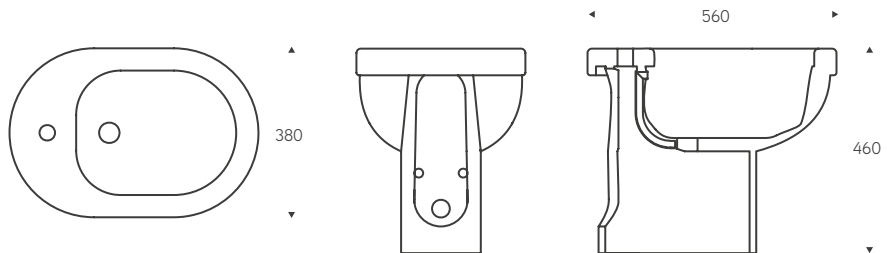

VARIANTI E DETTAGLI
VERSIONS AND DETAILS



MATERIALI vaso: vitreous china (disponibile anche con apertura frontale)
sedile: mdf, poliestere, ottone

SCARICO WC unificato

SEDILE sedile con coperchio per vaso
versioni: standard, soft close

WC e sedile disponibili anche con apertura frontale

MATERIALS vitreous china (available also with frontal opening)
seat: mdf, polyester, brass

DRAINAGE single

SEAT seat with cover for wc
versions: standard, soft close

WC and seats available also with frontal opening

note tecniche **technical details**

SENIOR 46

LAVABO WASHBASIN

DIMENSIONI mm
DIMENSIONS mm

lavabo
washbasin

L 640
H 150
P 480

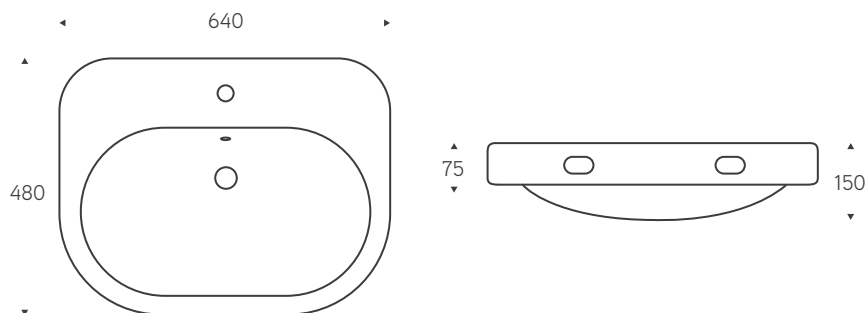

VARIANTI E DETTAGLI
VERSIONS AND DETAILS



MATERIALI	vitreous china
DOTAZIONI	troppo pieno, foro per piletta standard
MATERIALS	vitreous china
EQUIPMENT	overflow, standard siphon hole

STYLE 47

La linea di sanitari Style 47 ha forme squadrate, avvolgenti e confortevoli ed un'altezza del WC e bidet di 47 cm per fare in modo che la seduta ed il rialzo siano agevoli e senza problemi. Il lavabo che completa la serie consente con la sua stondatura sul davanti un avvicinamento più agevole e quindi un utilizzo facilitato del rubinetto e offre un design particolare, elegante e raffinato.

.....

Style 47 sanitaryware series has squared lines, surrounding and comfortable shapes and a height of 47 cm for the WC and the bidet to make the seating and the getting up easy and without any problem. The washbasin, that completes the series, allows with its rounding front shape an easier approach and therefore a simpler use of the faucet and offers a particular design, elegant and sophisticated.



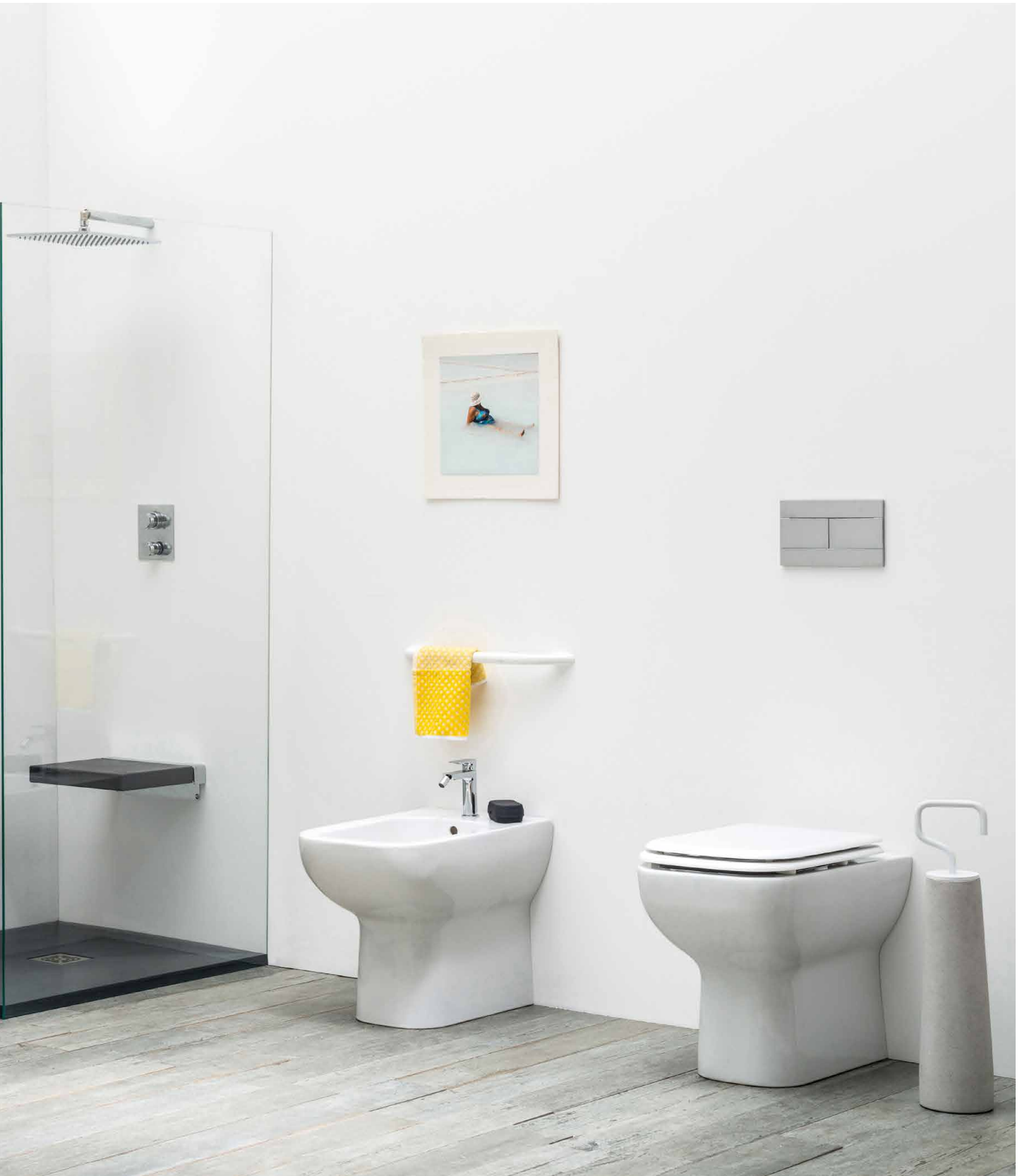



STYLE 47



STYLE 47

SANITARI SANITARY WARE

DIMENSIONI mm
DIMENSIONS mm

vaso

wc

L 380

H 470

P 590

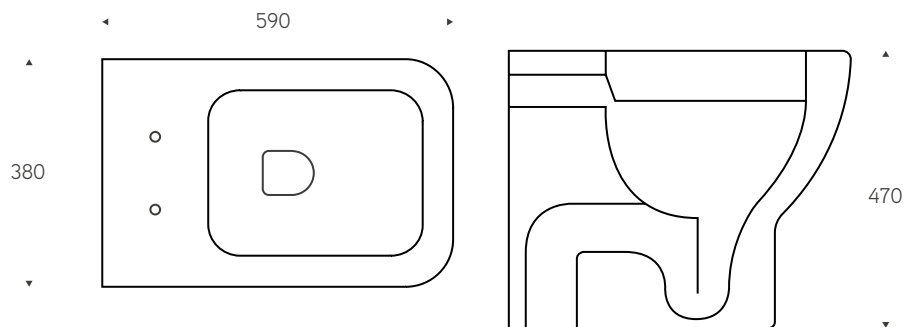

bidet

bidet

L 380

H 470

P 590

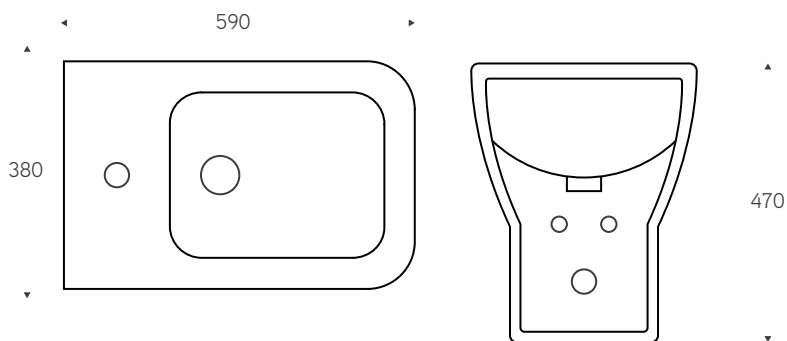

VARIANTI E DETTAGLI
VERSIONS AND DETAILS



MATERIALI

vaso: vitreous china
sedile: mdf, poliestere, ottone

SCARICO WC

unificato

SEDILE

sedile con coperchio per vaso
versioni: standard, soft close

MATERIALS

vitreous china
seat: mdf, polyester, brass

DRAINAGE

single

SEAT

seat with cover for wc
versions: standard, soft close

note tecniche **technical details**

STYLE 47

LAVABO WASHBASIN

DIMENSIONI mm
DIMENSIONS mm

lavabo
washbasin

L 715
H 150
P 570

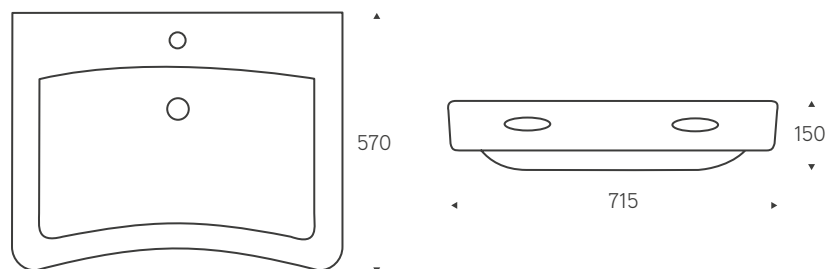

VARIANTI E DETTAGLI
VERSIONS AND DETAILS



MATERIALI	vitreous china
DOTAZIONI	troppo pieno, foro per piletta standard
MATERIALS	vitreous china
EQUIPMENT	overflow, standard siphon hole



sedili doccia **shower seats**



T U C K

.....

Design

Gianni Arduini
&
Marco Frigerio

.....



Tre sedili tecnologici che entrano in bagno per offrire design e comfort e per trasformare il tempo della doccia in un momento gratificante per il corpo e la mente.
.....

Three technological seats that get into the bathroom to offer design and comfort and to transform shower time in a rewarding moment for the body and the mind.

T U C K - T Y P E





TUCK-TYPE

un sedile innovativo, brevettato da Thermomat, in poliuretano morbido, che si estende come un pannello, dotato di un particolare meccanismo che permette di sollevare l'estremità inferiore del pannello per configurare la seduta.

.....

TUCK-TYPE

an innovative seat, patented by Thermomat, made of soft polyurethane, which extends as a panel, equipped with a special mechanism that allows you to lift the lower end of the panel and set the seat.



T U C K - T Y P E



TUCK-TALL

seduta in poliuretano morbido con sedile regolabile in altezza per assecondare le esigenze di tutta la famiglia. Il sedile si regola e ripiega su se stesso grazie ad una piastra in acciaio applicata a muro.

.....

TUCK-TALL

soft polyurethane seat with seat adjustable in height to meet the needs of the whole family. The seat adjusts and folds on itself due to a wall mounted steel plate.

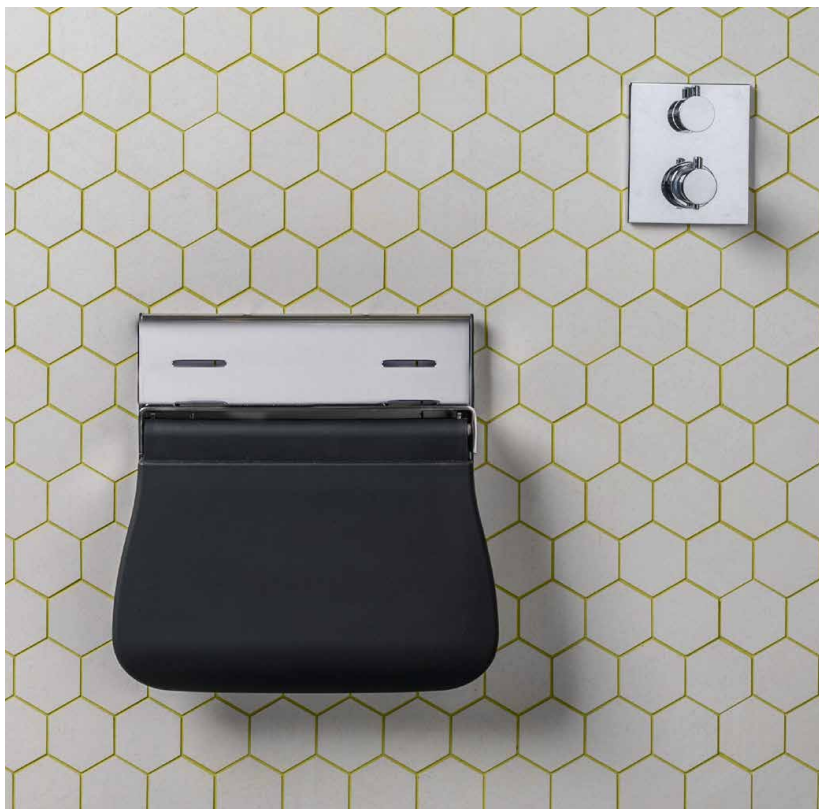

TUCK - TALL





TUCK - TALL



TUCK-TRAY

seduta in poliuretano morbido, che si ripiega verticalmente grazie a un meccanismo racchiuso in una piastra in acciaio applicata a muro.

.....

TUCK-TRAY

soft polyurethane seat for the utmost comfort that folds vertically due to a mechanism enclosed in a wall mounted steel plate.



TUCK - TALL



TUCK

.....

SEDILI DOCCIA SHOWER SEATS

DIMENSIONI mm
DIMENSIONS mm

Tuck - Type

L 369
H 828
P 369

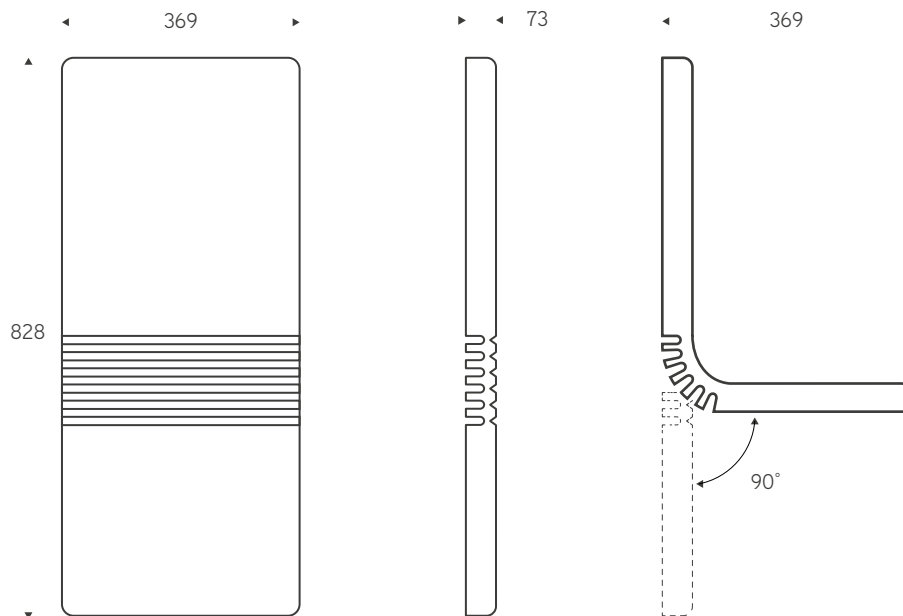

VARIANTI E DETTAGLI VERSIONS AND DETAILS



MATERIALI	acciaio, poliuretano
PORTATA	150 kg
COLORI	seduta: bianco, nero
In tutti i sedili è possibile sostituire solo la seduta (con relativo telaio)	
MATERIALS	steel, polyurethane
LOAD	150 kg
COLOURS	seats: white, black
In all models it is possible to replace only the seats (with the relevant internal frame)	

T U C K

.....
SEDILI DOCCIA SHOWER SEATS

DIMENSIONI mm
DIMENSIONS mm

Tuck - Tall

L 416
P 321

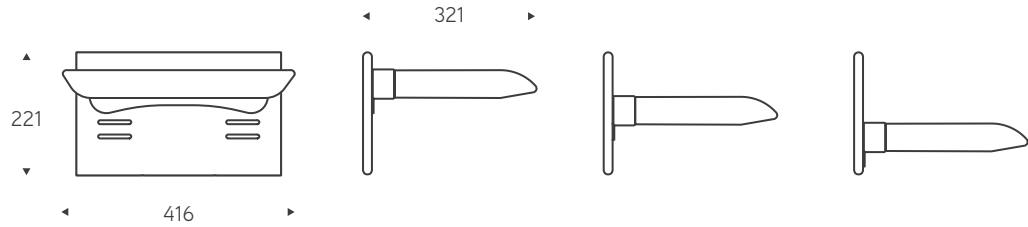

Tuck - Tray

L 416
P 306

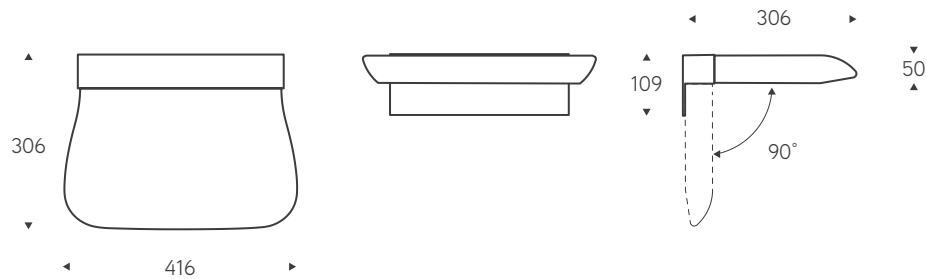

VARIANTI E DETTAGLI VERSIONS AND DETAILS



MATERIALI acciaio, poliuretano
PORTATA 150 kg
COLORI seduta: bianco, nero

In tutti i sedili è possibile sostituire solo la seduta (con relativo telaio)

MATERIALS steel, polyurethane
LOAD 150 kg
COLOURS seats: white, black

In all models it is possible to replace only the seats (with the relevant internal frame)



sedili doccia **shower seats**



S T Y L E



STYLE

la seduta in poliuretano morbido ed una tenuta di 130 kg garantiscono il massimo della sicurezza e del comfort. La piastra di fissaggio a parete in acciaio inox offre un ingombro ridottissimo, permettendo ai sedili di richiudersi completamente.

.....

This soft polyurethane seat, and the maximum load weight of 130 kg, ensure the highest level of safety and comfort. The steell fixing plate, wall mounted, is a space-saving system, and it allows seats to a fully closing.





STYLE ECLYPSE

ha un design minimale, arrotondato e forme ultra piatte. La seduta in poliuretano morbido e l'inserto in alluminio satinato per il fissaggio a muro. Offre un comfort assoluto e, una volta richiuso, un ridottissimo ingombro di soli 4 cm.

.....

The soft polyurethane seat and the satin aluminium insert for the wall mounted fixing system, are characteristics which ensure a great comfort but, once closed, it takes just a minimal space (only 4 cm).





STYLE ROUND

linee eleganti e funzionali. La seduta in poliuretano morbido, dalla forma arrotondata, offre il massimo comfort anche in box doccia di misura ridotta mentre la robusta struttura, in alluminio verniciato, garantisce sicurezza assoluta grazie alla tenuta di 150 Kg.

.....

Elegance and functionality. The soft polyuretane seat, with round shape, offers maximum comfort also in small shower corners while the robust structure, in painted aluminium, grants the maximum safety thanks to a 150 kg load.

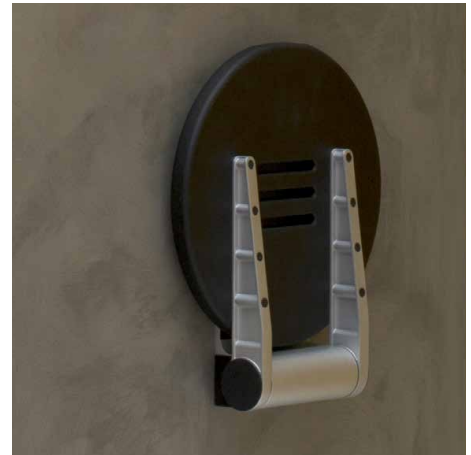

STYLE

SEDILI DOCCIA SHOWER SEATS

DIMENSIONI mm
DIMENSIONS mm

Style

L 355
P 325

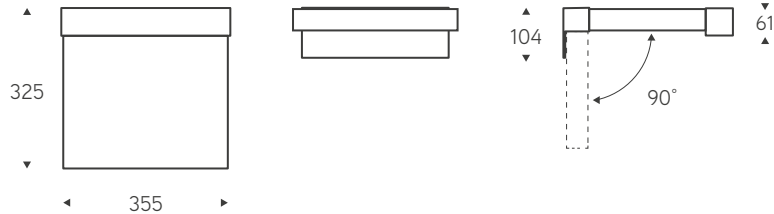

Style Eclipse

L 390
P 340

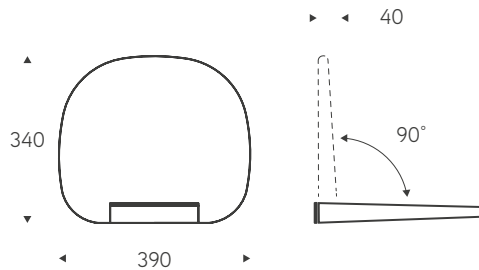

Style Round

L 171
P 419

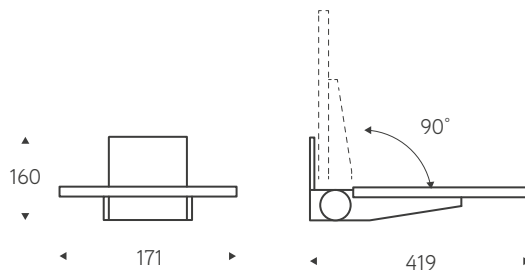

VARIANTI E DETTAGLI VERSIONS AND DETAILS



MATERIALI	Style, Style Eclipse: lamiera INOX AISI 304 lucidato, poliuretano morbido Style Round: alluminio, poliuretano morbido
PORTATA	Style, Style Eclipse: 130 kg Style Round: 150 kg
COLORI	Style, Style Eclipse: bianco, antracite Style Round: antracite
MATERIALS	Style, Style Eclipse: stainless steel frame AISI 304, soft polyurethane Style Round: aluminium, soft polyurethane
LOAD	Style, Style Eclipse: 130 kg Style Round: 150 kg
COLOURS	Style, Style Eclipse: white, anthracite Style Round: anthracite





T - S T O N E

La serie di piatti doccia in marmoresina T-STONE presenta una gamma attuale e adattabile a qualsiasi spazio. Numerose finiture, dimensioni e versioni “su misura” soddisfano le richieste più esigenti. Le varie colorazioni consentono di adattarsi a qualsiasi bagno e stile. Il materiale high-tech garantisce il massimo del comfort e della sicurezza grazie alle proprietà anti-scivolo ed antibatteriche. Adatto sia ad installazioni domestiche che ad ambienti ricettivi come hotel, palestre, piscine, luoghi chiusi o all’aperto.

.....

T-STONE, a range of Marble-resin mass dyed shower trays, contemporary and suitable for any space.

A large number of finishes and dimensions, tailor-made versions are available in order to satisfy any kind of request. Because of the range of colours, you can fit it in every bathroom, independently from the style. The high-tech material used guarantees an high level of safety and comfort, thanks to antibacterial and anti-slip properties. Suitable for domestic installation and for accommodation facilities like hotels, gyms, and swimming pools.



T - S T O N E





T - S T O N E



PANNELLI LATERALI T-STONE

disponibili nella stessa finitura e colorazione del piatto doccia, utili nel caso si desideri sostituire la vasca con un piatto doccia coprendo i lati precedentemente occupati dalla vasca. I pannelli vengono consegnati già tagliati nella misura desiderata semplificando le operazioni di montaggio e ottenendo così il miglior risultato estetico e funzionale.

.....

T-STONE SIDE PANELS

are available in the same finish and color of shower trays, a useful solution if you are replacing the bathtub with a shower tray by covering the sides previously occupied with the bathtub. The panels are delivered already cut to the desired size simplifying the assembly operations and thus obtaining the best aesthetic and functional result.



T - S T O N E

.....

PIATTI DOCCIA SHOWER TRAYS

DIMENSIONI cm
DIMENSIONS cm

COLORI
COLORS

FINITURE
FINISHES

piatti doccia shower trays

70 x 100 - 110 - 120 - 130
140 - 150 - 160 - 170
180 - 190 - 200

80 x 100 - 110 - 120 - 130
140 - 150 - 160 - 170
180 - 190 - 200

90 x 100 - 110 - 120 - 130
140 - 150 - 160 - 170
180 - 190 - 200



bianco cod. BC
white cod. BC



crema cod. BC
white cod. BC



pizzarra cod. 03
pizzarra cod. 03

pannelli doccia shower panels

70 x 70 - 80 - 90 - 100
110 - 120 - 130 - 140
150 - 160 - 170 - 180
190 - 200



antracite cod. AN
anthracite cod. AN



grigio cemento cod. GR
cement grey cod. GR

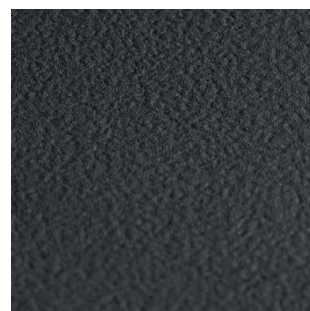

sintetic cod. 04
sintetic cod. 04

.....

VARIANTI E DETTAGLI VERSIONS AND DETAILS



MATERIALI
FINITURE
FINITURE
DOTAZIONI

MATERIALS
FINISHES
COLOURS
PROVIDED

Materiale: marmoresina colorato in massa
pizzarra, sintetico
antracite, grigio cemento, crema, bianco
piatti doccia: sifone e griglia copri scarico

marble resin mass dyed
pizzarra, sintetico
anthracite, cement grey, cream, white
shower trays: s-trap, grid cover-flush





RUBINETTI

t a p s



Monocomando da incasso con bocca di erogazione.

.....

Wall built-in mixer with spout.



RUBINETTI taps

RUBINETTI

RUBINETTI TAPS

DIMENSIONI mm
DIMENSIONS mm

monocomando da lavabo
washbasin mixer tap

L 36
H 160
P 174

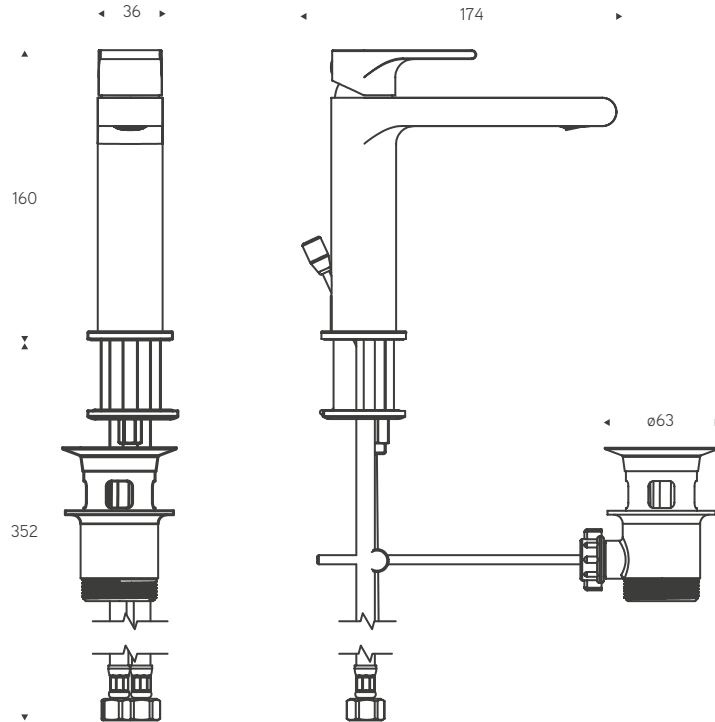

VARIANTI E DETTAGLI
VERSIONS AND DETAILS



MATERIALI	ottone, zama, altro
FINITURE	cromato, bianco opaco, nero opaco, ottone nichelato
INSTALLAZIONE	su lavabo
MATERIALS	brass, zama, other
FINISHES	chrome plated brass, matt white, matt black, nickel plated
FIXING	on washbasin

RUBINETTI

RUBINETTI TAPS

DIMENSIONI mm
DIMENSIONS mm

monocomando da bidet
bidet mixer tap

L 36
H 143
P 154

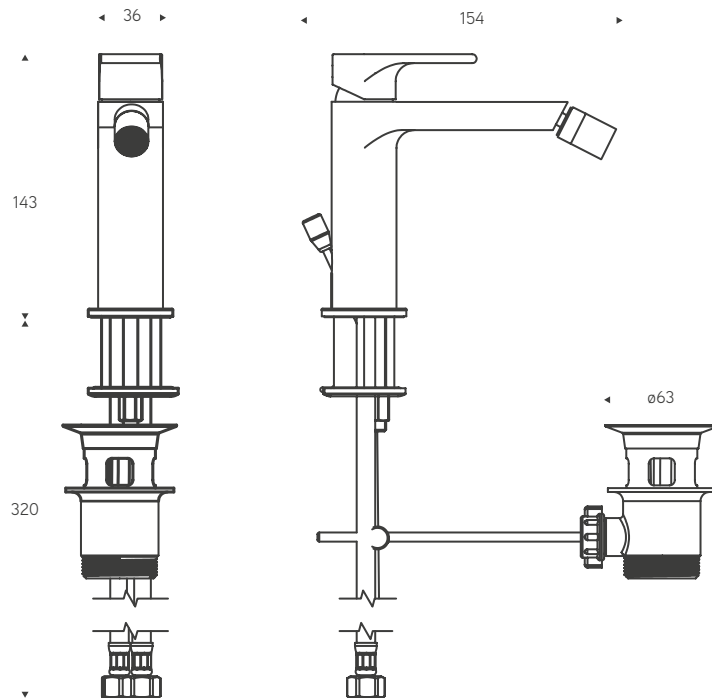

VARIANTI E DETTAGLI
VERSIONS AND DETAILS



MATERIALI	ottone, zama, altro
FINITURE	cromato, bianco opaco, nero opaco, ottone nichelato
INSTALLAZIONE	su bidet
MATERIALS	brass, zama, other
FINISHES	chrome plated brass, matt white, matt black, nickel plated
FIXING	on bidet

note tecniche **technical details**

RUBINETTI

RUBINETTI TAPS

DIMENSIONI mm
DIMENSIONS mm

monocomando da lavabo
washbasin mixer tap

L 170
H 90
P 177

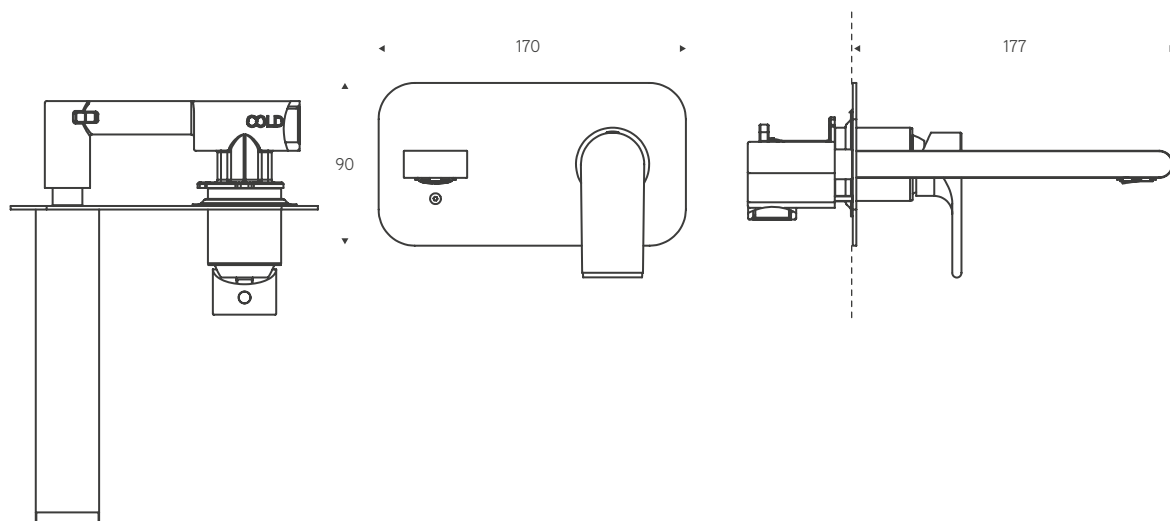

VARIANTI E DETTAGLI
VERSIONS AND DETAILS



MATERIALI	ottone, zama, altro
FINITURE	cromato, bianco opaco, nero opaco, ottone nichelato
INSTALLAZIONE	incasso a parete per lavabo
MATERIALS	brass, zama, other
FINISHES	chrome plated brass, matt white, matt black, nickel plated
FIXING	wall installation



ACCESSORI

accessories



RING

portasalviette con fissaggio a parete in faggio naturale.

.....

Natural beechwood Towel holder wall mounted.



R I N G

R I N G

.....

PORTASALVIETTE TOWEL HOLDER

DIMENSIONI mm
DIMENSIONS mm

portasalviette
towel holder

ø 60
P 30

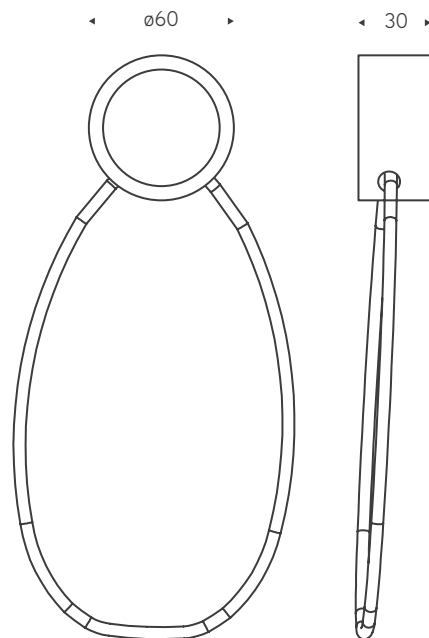

.....

VARIANTI E DETTAGLI
VERSIONS AND DETAILS



MATERIALI	faggio
	corda: nylon
FISSAGGIO	a muro
MATERIALS	beechwood
MOUNTING	wall mounted

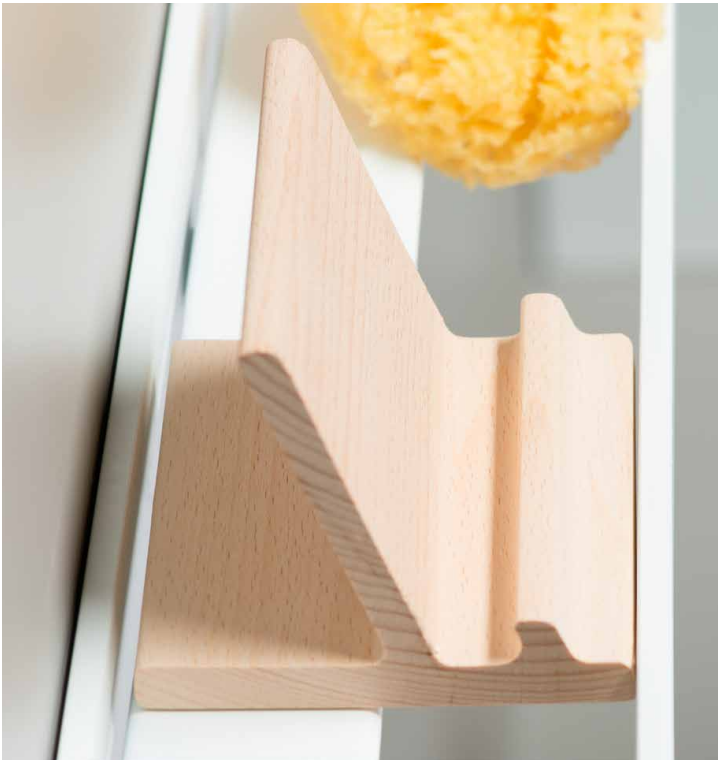

I - PAD STAND

porta iPad posizionabile sulle mensole o libero.

.....

I - PAD STAND

iPad holder that can be free-standing or positioned on the shelves.



I - P A D S T A N D

I - P A D S T A N D

PORTA IPAD IPAD HOLDER

DIMENSIONI mm
DIMENSIONS mm

I-Pad stand

L 100
H 78
P 92,5

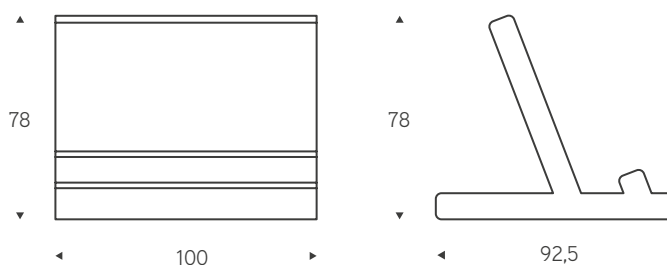

VARIANTI E DETTAGLI VERSIONS AND DETAILS



MATERIALI

multistrato legno di faggio

FINITURE

faggio naturale

NOTE

Note: il prodotto consente l'appoggio dell'Ipad o di altri tablet con e senza custodia, sia in orizzontale che in verticale, senza coprire lo schermo. Realizzato in 3 parti di spessore 10 mm incastrate e incollate

MATERIALS

multi-layer beechwood

FINISHES

natural beechwood

NOTES

this product allows the Ipad or other tablets to be leaned with our without case, horizontally or vertically, without covering the screen. Made of 3 elements, 10mm thick, embed and glued



SPECCHIO

Disponibile nelle versioni tonda e rettangolare.

.....

MIRROR

Available in round and rectangular versions.



PROP

SPECCHI MIRRORS

DIMENSIONI mm
DIMENSIONS mm

specchio rotondo
rounded mirror

Ø 640
P 10

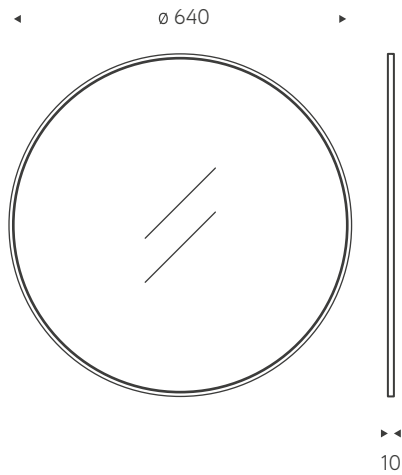

specchio rettangolare
rectangular mirror

L 389
H 699
P 10

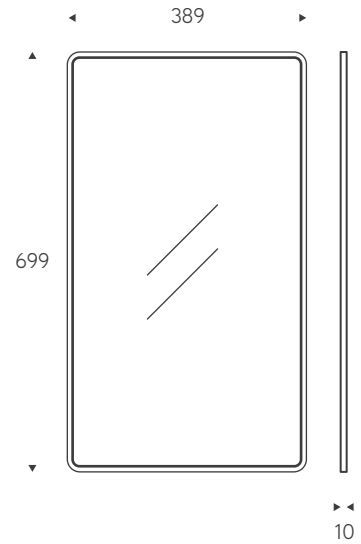

VARIANTI E DETTAGLI
VERSIONS AND DETAILS

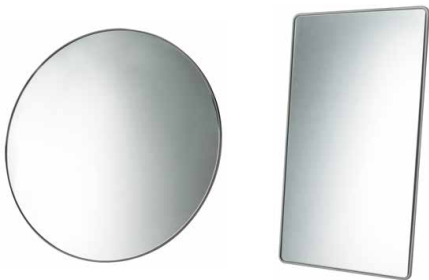

MATERIALI vetro di sicurezza, legno naturale verniciato
COLORI fondo: bianco, grigio, nero
MATERIALS safety glass, natural painted wood
COLOURS background: white, grey, black

BRUNT

porta scopino in ottone.
Finiture: in bianco opaco,
grigio porpora opaco.

.....

BRUNT

toilet brush holder - Solid Brass.
Finishes: opaque white,
opaque purple grey.



LISSOM

porta scopino in ottone.
Finiture: in bianco opaco,
grigio porpora opaco.

.....

LISSOM

toilet brush holder - Solid Brass.
Finishes: opaque white,
opaque purple grey.



BRUNT - LISSOM

PORTASCPINI TOILET BRUSH HOLDER

DIMENSIONI mm
DIMENSIONS mm

Brunt

L 80
H 344

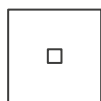
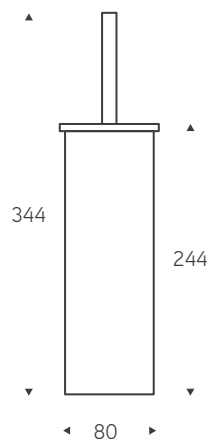

Lissom

ø 80
H 344

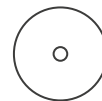
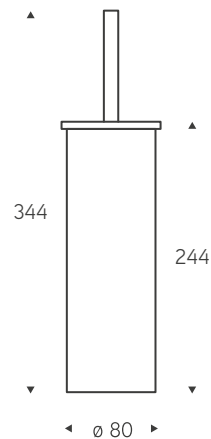

VARIANTI E DETTAGLI VERSIONS AND DETAILS



MATERIALI	ottone
FINITURE	Brunt: bianco opaco, grigio porpora opaco Lissom: bianco opaco, grigio porpora opaco
MATERIALS	brass
DIMENSIONS	Brunt: opaque white, opaque purple grey Lissom: opaque white, opaque purple grey

BICCHIERI

per mensole Brunt, Lissom e Prop.

.....

ALUMINIUM TUMBLERS

for Brunt, Lissom and Prop shelves.



DISPENSER

dosasapone per mensole Brunt, Lissom e Prop.

.....

DISPENSER

soap dispenser for Brunt, Lissom and Prop shelves.



BICCHIERI E DISPENSER

tumblers and dispenser

ACCESSORI ACCESSORIES

DIMENSIONI mm
DIMENSIONS mm

bicchieri
aluminium tumbler

ø 60
H 79

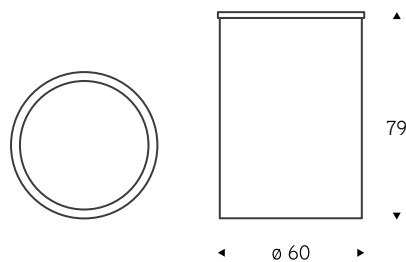

dispenser
dispenser

ø 50
H 129



VARIANTI E DETTAGLI
VERSIONS AND DETAILS



MATERIALI

bicchieri: alluminio verniciato
dispenser: flacone PET, pompetta ABS

FINITURE

bicchieri: bianco opaco, grigio porpora opaco, anodizzato,
nero opaco

MATERIALS

tumbler: painted aluminium
dispenser: bottle PET, pump ABS

DIMENSIONS

tumbler: opaque white, opaque purple grey, anodized,
opaque black

TABELLE DI CONVERSIONE

Conversion
tables

tabelle di conversione / conversion tables

tabella di conversione sistema metrico - anglosassone / conversion table for metric system and uk system

1 mm	=	0,04 In
1 mt	=	39,37 In
1 Kg	=	2,20 Lb
1 °C	=	33,8 °F
1 lt	=	0,26 Gal

.....

DOT - pg. 7

1,50 mm	=	0,06 in
10,00 mm	=	0,39 in
12,00 mm	=	0,47 in
38,00 mm	=	1,50 in
42,00 mm	=	1,65 in
50,00 mm	=	1,97 in
70,00 mm	=	2,76 in
79,00 mm	=	3,11 in
175,00 mm	=	6,89 in
550,00 mm	=	21,65 in
600,00 mm	=	23,62 in
1100,00 mm	=	43,31 in
120,00 Kg	=	264,55 Lb

.....

PROP - pg. 29

10,00 mm	=	0,39 in
12,00 mm	=	0,47 in
32,00 mm	=	1,26 in
55,00 mm	=	2,17 in
60,00 mm	=	2,36 in
78,50 mm	=	3,09 in
105,00 mm	=	4,13 in
107,00 mm	=	4,21 in
205,00 mm	=	8,07 in
233,00 mm	=	9,17 in
389,00 mm	=	15,31 in
483,00 mm	=	19,02 in

PROP - pg. 29

640,00 mm	=	25,20 in
680,00 mm	=	26,70 in
699,00 mm	=	27,52 in
840,00 mm	=	33,07 in
1140,00 mm	=	44,88 in
120,00 Kg	=	264,55 Lb

.....

SHINE - pg. 43

32,00 mm	=	1,26 in
107,00 mm	=	4,21 in
500,00 mm	=	16,69 in
650,00 mm	=	25,59 in
800,00 mm	=	31,50 in
120,00 Kg	=	264,55 Lb

.....

FEEL - pg. 53

32,00 mm	=	1,26 in
107,00 mm	=	4,21 in
350,00 mm	=	13,78 in
450,00 mm	=	17,72 in
600,00 mm	=	23,62 in
800,00 mm	=	31,50 in
120,00 Kg	=	264,554 lb

.....

STYLE - pg. 61

8,00 mm	=	0,31 in
28,00 mm	=	1,10 in
32,00 mm	=	1,26 in
73,00 mm	=	2,87 in
94,00 mm	=	3,70 in
130,00 mm	=	5,12 in
183,00 mm	=	7,20 in
234,00 mm	=	9,21 in

STYLE - pg. 61

258,00 mm	=	10,16 in
350,00 mm	=	13,78 in
420,00 mm	=	16,54 in
450,00 mm	=	17,72 in
460,00 mm	=	18,11 in
520,00 mm	=	20,47 in
522,00 mm	=	20,55 in
550,00 mm	=	21,65 in
607,00 mm	=	23,90 in
620,00 mm	=	24,41 in
650,00 mm	=	25,59 in
720,00 mm	=	28,35 in
750,00 mm	=	29,53 in
820,00 mm	=	32,28 in
150,00 Kg	=	330,69 Lb

.....

STREET - pg. 105

146,00 mm	=	5,75 in
642,00 mm	=	25,28 in

.....

RUNG - pg. 113

40,00 mm	=	1,57 in
48,00 mm	=	1,89 in
111,00 mm	=	4,37 in
380,00 mm	=	14,96 in
400,00 mm	=	15,75 in
410,00 mm	=	16,14 in
435,00 mm	=	17,13 in
465,00 mm	=	18,31 in
589,00 mm	=	23,19 in
627,00 mm	=	24,69 in
815,00 mm	=	32,09 in
928,00 mm	=	36,54 in

GAMBOL - pg. 95

30,00 mm	=	1,18 in
235,00 mm	=	9,25 in
600,00 mm	=	23,62 in
1250,00 mm	=	49,21 in
2500,00 mm	=	98,43 in

.....

BRUNT - pg. 73

40,00 mm	=	1,57 in
100,00 mm	=	3,94 in
105,00 mm	=	4,13 in
140,00 mm	=	5,51 in
145,00 mm	=	5,71 in
1000,00 mm	=	39,37 in
150,00 Kg	=	330,69 lb

.....

LISSOM - pg. 85

80,00 mm	=	3,15 in
81,00 mm	=	3,19 in
100,00 mm	=	3,94 in
105,00 mm	=	4,13 in
125,00 mm	=	4,92 in
145,00 mm	=	5,71 in
200,00 mm	=	7,87 in
225,00 mm	=	8,86 in
300,00 mm	=	11,81 in
375,00 mm	=	14,76 in
450,00 mm	=	17,72 in
525,00 mm	=	20,67 in
600,00 mm	=	23,62 in
150,00 Kg	=	330,69 lb

LINK - pg. 127

170 mm	=	6,69 in
505 mm	=	19,88 in
552 mm	=	21,73 in
600 mm	=	23,62 in
120,00 Kg	=	264,55 lb

.....

BOUNCE - pg. 139

180,00 mm	=	7,09 in
210,00 mm	=	8,27 in
351,00 mm	=	13,82 in
352,00 mm	=	13,86 in
356,00 mm	=	14,02 in
363,00 mm	=	14,29 in
414,00 mm	=	16,30 in
560,00 mm	=	22,05 in
586,00 mm	=	23,07 in
602,00 mm	=	23,70 in
715,00 mm	=	28,15 in
877,00 mm	=	34,53 in
150,00 Kg	=	330,69 lb

.....

STONY - pg. 153

180 mm	=	7,09 in
419 mm	=	16,50 in
430 mm	=	16,93 in

.....

BOING - pg. 161

70,00 mm	=	2,76 in
88,00 mm	=	3,46 in
140,00 mm	=	5,51 in
210,00 mm	=	8,27 in
351,00 mm	=	13,82 in
363,00 mm	=	14,29 in

BOING - pg. 161

400,00 mm	=	15,75 in
414,00 mm	=	16,30 in
448,00 mm	=	17,64 in
586,00 mm	=	23,07 in
598,00 mm	=	23,54 in
602,00 mm	=	23,70 in

.....

SANITARI - pg. 171

35,00 mm	=	1,38 in
50,00 mm	=	1,97 in
75,00 mm	=	2,95 in
150,00 mm	=	5,91 in
160,00 mm	=	6,30 in
260,00 mm	=	10,24 in
265,00 mm	=	10,43 in
280,00 mm	=	11,02 in
290,00 mm	=	11,42 in
300,00 mm	=	11,81 in
330,00 mm	=	12,99 in
350,00 mm	=	13,78 in
365,00 mm	=	14,37 in
370,00 mm	=	14,57 in
380,00 mm	=	14,96 in
420,00 mm	=	16,54 in
430,00 mm	=	16,93 in
440,00 mm	=	17,32 in
450,00 mm	=	17,72 in
460,00 mm	=	18,11 in
470,00 mm	=	18,50 in
480,00 mm	=	18,90 in
515,00 mm	=	20,28 in
520,00 mm	=	20,47 in
560,00 mm	=	22,05 in

◦ Credits

Art direction: Monica Graffeo

Graphic: Telegrafici

Photo: Paolo Barni, Mirko Vegliò

Styling: Elena Caponi e Monica Porta - Rosanna Bignucolo

Valentina Raffaelli e Alice Spadaro (32-37, 46-48, 50-51, 56-59, 66-69, 74-79, 92 190-193, 196-199)

Thanks to:

CALE'

CERAMICA SANT'AGOSTINO

[COMFORT ZONE]

DAVIDE MONTANARO

KASTHALL

LIVING DIVANI

SCARAZZINI

TRABO

ZUCCHETTI / KOS

HAY

NORMANN COPENHAGEN

Special thanks to: Simone and Vito

2017 edition

EVER LIFE DESIGN

by Thermomat Saniline s.r.l.

Via M. Curie 7

46034 Borgo Virgilio (MN)

www.everlifedesign.it

Texts and photos contained in this catalogue are protected by copyright and exclusive propriety of Thermomat Saniline S.r.l.

Any use, except when previously authorised by Thermomat Saniline S.r.l., is therefore strictly forbidden and legally actionable. The photos here published may not reflect real dimensions The products can be subject to changes without notice (both dimensional and aesthetical). Errors and omissions excepted.

Tutti i testi e le immagini rappresentate in questo catalogo sono protetti da copyright e di proprietà esclusiva di Thermomat Saniline S.r.l.

Pertanto qualsiasi uso, fatta salva preventiva autorizzazione scritta di Thermomat Saniline S.r.l., è assolutamente vietato e legalmente perseguibile. Le foto qui pubblicate possono anche non rispecchiare le reali misure. I prodotti possono subire modifiche senza preavviso, sia dimensionali sia estetiche. Salvo errori e omissioni.

XCATEVER – CL – ED 05/17 – Rev.01

www.everlifedesign.it

ALL MADE IN ITALY